

envirovent

QURO LC

Decentralised Mechanical Extract Fan



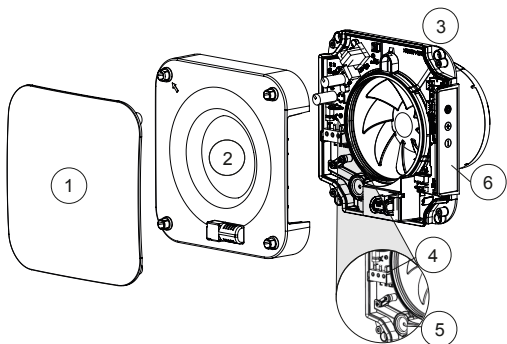

Fig. 1

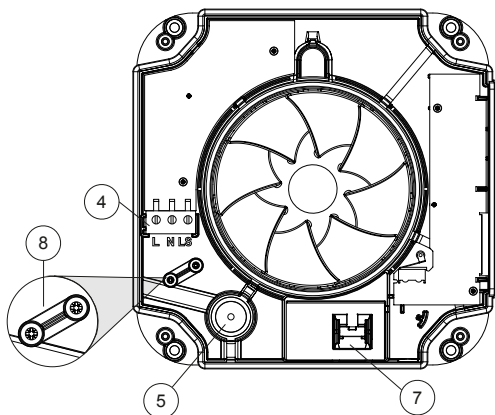

Fig. 2

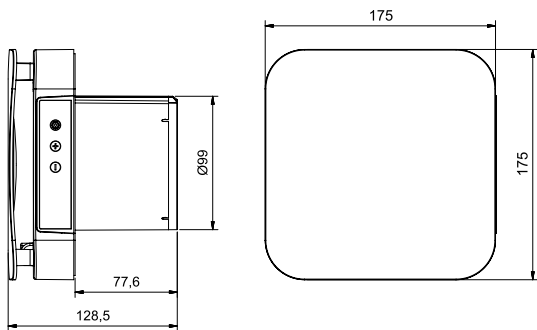
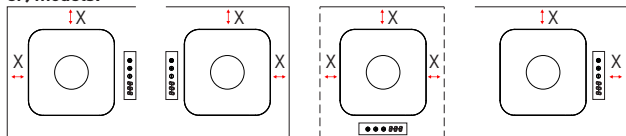

Fig. 3

Minimum Installation Distances and Orientations

X > 5 cm / 2 inch

QURO LC QRST-LC (Timer) and QRHT-LC (Relative Humidity Sensor and Timer) models:



QURO LC QRHTP-LC (Relative Humidity Sensor, Timer and Pullcord) model:

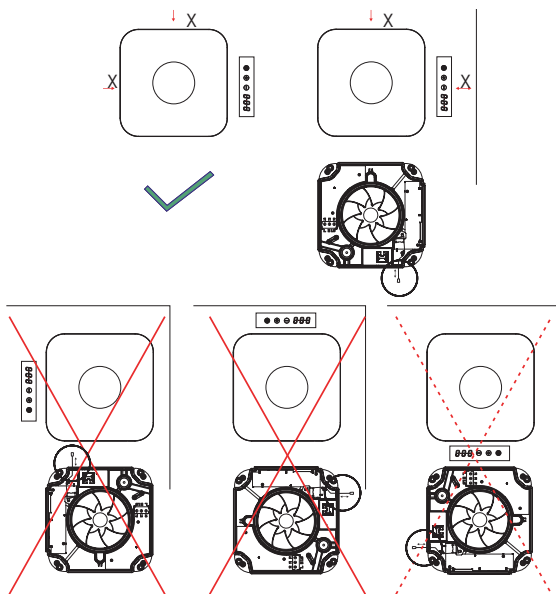
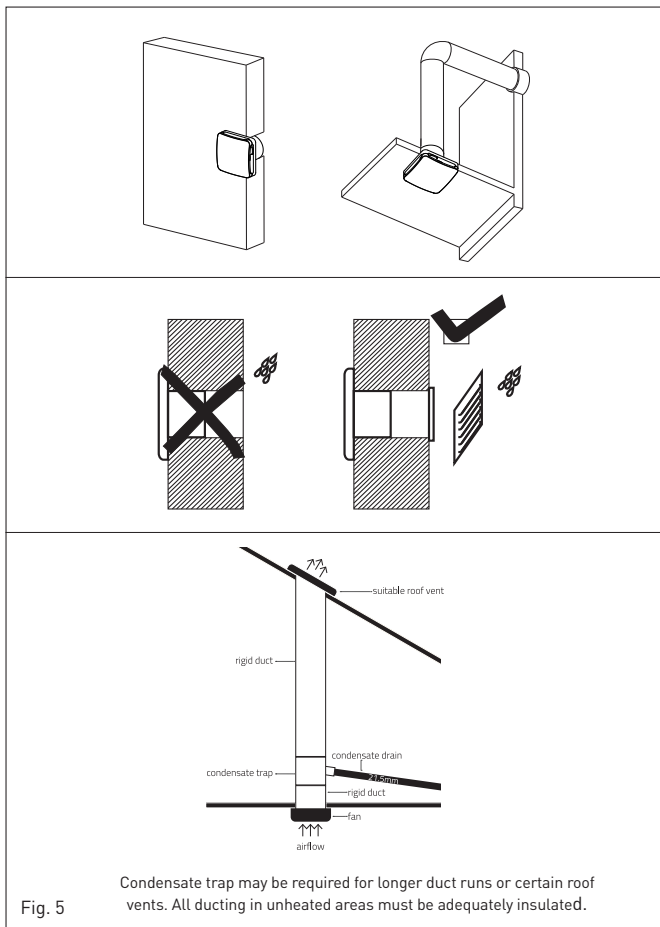

Fig. 4



Condensate trap may be required for longer duct runs or certain roof vents. All ducting in unheated areas must be adequately insulated.

Fig. 5

QURO LC
QRST-LC model

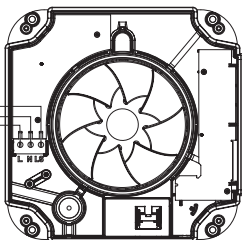
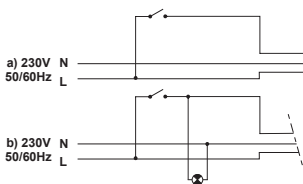
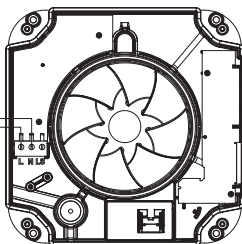

Fig. 6

QURO LC
QRHT-LC model

230V N
50/60Hz L

1)



2)

a) 230V N
50/60Hz L

b) 230V N
50/60Hz L

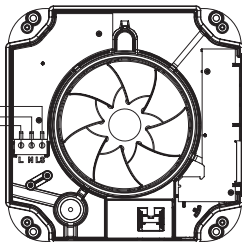
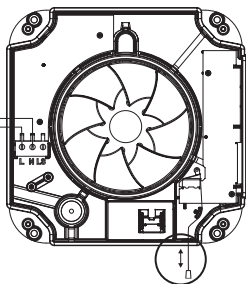

Fig. 7

QURO LC
QRHTP-LC model

230V N
50/60Hz L

1)



2)

a) 230V N
50/60Hz L

b) 230V N
50/60Hz L

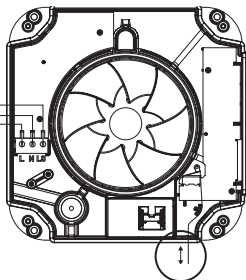
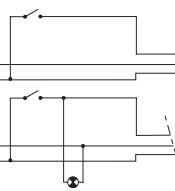

Fig. 7

This instruction manual contains important information and must be read carefully by qualified individuals before any handling, transport, inspection or installation of the product. While every care has been taken in the preparation of these instructions and the information given, it is the responsibility of the installer to ensure that the system complies with the national and international regulations in force, particularly those relating to safety. envirovent Ltd, accepts no responsibility for breakages, accidents or other problems due to failure to follow the instructions in this manual.

The extract fans in the QURO LC range are manufactured under strict production and quality control standards, such as ISO 9001. All the components are checked and all units are tested after assembly.

We recommend that you check that the model is correct and the details on the marking plate are as required including temperature range and electrical information.

IMPORTANT: Before proceeding with installation and connection of the device, make sure that power is switched off at the mains. The ambient operating temperature

must be within the specific limits on the marking plate. If the extract fan is connected to a duct, it must be used exclusively for the ventilation system. Do not use this device in explosive or corrosive atmospheres. If the fan extracts air in a room where a boiler or other combustion device is installed, make sure that there are sufficient air inlets and outlets in the room to ensure proper combustion.

Children aged 8 and up can use this device, as can individuals with physical, sensory or mental disabilities, or who lack experience

and knowledge, when supervised or trained to use the device safely and made aware of the dangers that may be involved. Children should not be allowed to play with the device. User cleaning and maintenance should not be done by unsupervised children.

The device can be mounted on the ceiling or wall, with outlet directly outside or into a dedicated duct.

This product is not suitable for use with a Type AC RCD .

INSTALLATION

IMPORTANT: The power supply cables must be run through the cable gland and the cable retention system as shown in labels 5 and 9 in Fig.2. The cross-section of the power supply cable must be at least 0.5mm². To control

the fan via a Ls, the options shown in Fig. 6, 7 and 8 should be used (depending on the version chosen).

Parts in Fig 1 and Fig 2:

- 1: Front Cover
- 2: Central cover
- 3: Back cover
- 4: Terminal strip
- 5: Cable gland
- 6: Display
- 7: Humidity sensor
- 8: Cable retention

VERSIONS

The QURO LC is a decentralised mechanical extract fan designed to operate continuously, providing a constant extraction of air at all times, for better indoor air quality.

- **Standard Model with Timer (QRST-LC):** This has several operating modes to vary the speed of the fan with over-run timer including several selectable trickle and boost speeds. The QRST-LC version must be connected as shown in Fig. 6. with three wires for switching from trickle to boost speeds (external switch and Ls).
- **Relative Humidity Sensor Model with Timer (QRHT-LC):** Offering the same features as the QRHT-LC version but with a humidity sensor. The QRST-LC version should use a two-wire connection, as shown in the first diagram in Fig. 7, to be triggered automatically by the

humidity sensor (switching from trickle to boost speed). It can also be connected as per the second diagram in Fig.7 if you want to force it to switch to the boost speed with an external switch via the Ls.

- **Relative Humidity Sensor Model with Timer and Pull Cord (QRHTP-LC):** Offering the same features as the QRHT-LC version, with a pull cord to allow for manual activation of the boost speed. It should be connected with two wires, as shown in the first diagram in Fig. 8, to be triggered automatically by the humidity sensor (increasing the fan speed as required). With the two-wire connection, it can be switched to boost speed using the pull cord. It can also be connected three wires and override the sensor to switch to boost speed using an external switch and Ls (second diagram Fig. 8). It is recommended that a manual override is provided within the UK.

OPERATING MODES AND MENUS

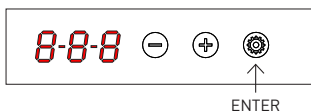

All QURO-LC models have a 7 segment display containing 3 digits. It has a keypad with "Enter", "+" and "-" keys to move through the menus. The

display menu is activated by pressing the "Enter" key and deactivated after 5 seconds if no further keys are pressed. The display digits can be reset by pressing the "Enter" key for more than 10 seconds and releasing it. In the operating instructions, trickle means the lowest speed and boost, the highest speed.

STEPS TO SET UP THE OPERATING MODES.

To access the menus, press "Enter" to activate the display, then use "+" and "-" to cycle through the menu. Once the option has been selected, press 'Enter' again. The parameter will blink, then press "+" or "-" to change the values and "Enter" to confirm.

BACK PRESSURE MENU

This menu gives an option to vary the back pressure detection through five options. These are as follows:

- S-01 (disabled/very low)
- S-02 (low)
- S-03 (normal)
- S-04 (high)
- S-05 (very high)

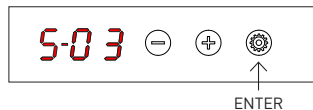

If S-01 is selected, the back pressure will not be detected, the factory setting is S-03.

INSTALLATION MENU (Wall or Ducted Installation)

- Wall installation is based upon 500mm of 100mm ducting plus 100mm suitable termination.
- Ducted installation is based upon 5m of 100mm ducting, 4x 100mm 90-degree bends and suitable 100mm termination.

If the installation is outside of these typical scenarios the airflows may be affected.

WALL INSTALLATION

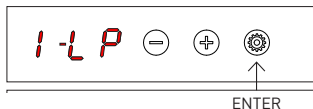

DUCTED INSTALLATION

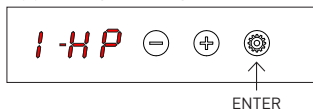

Factory setting of Ducted Installation (HP)

TRICKLE SPEED MENU (low speed) (QRST-LC, QRHT-LC, QRHTP-LC versions)

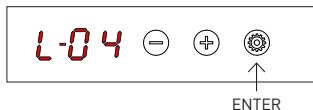

At the default setting, the fan will run continuously at trickle speed.

- Trickle airflow options from setting 1 (5l/s) to 15 (19l/s) in 1l/s increments.
- Factory setting: 8 l/s (L-04).

TYPICAL INSTALLATION OPTIONS

Setting	Wall (l/s)	Ducted (l/s)
1	5	5
2	6	6
3	7	7
4	8	8
5	9	9
6	10	10
7	11	11
8	12	12
9	13	13
10	14	14
11	15	15
12	16	16
13	17	17
14	18	18
15	19	19

BOOST SPEED MENU (high speed) (QRST-LC, QRHT-LC, QRHTP-LC versions)

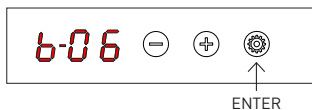

The fan will switch to high (boost) speed when activated by an external switch (all versions) , and the pull cord is pulled (QRHTP-LC version) or when the relative humidity setpoint is exceeded (QRHT-LC and QRHTP-LC versions). The fan will return to the trickle speed flow rate after the time set in the timer menu has elapsed or the RH/external switch has been deactivated.

- Boost airflow options from setting 1 (20l/s) to 10 (30l/s in 1l/s increments).
- Factory setting: 25 l/s wall, 22 l/s ducted, (b-06)

TYPICAL INSTALLATION OPTIONS

Setting	Wall (l/s)	Ducted (l/s)
1	20	20
2	21	21
3	22	22
4	23	22
5	24	22
6	25	22
7	26	22
8	27	22
9	28	22
10	28	22

TIMER MENU (QRST -LC, QRHT -LC, QRHTP -LC versions)

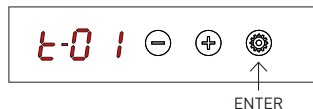

The fan will run at the boost speed for the time set in this menu when the humidity or Ls event ends and before returning to the trickle speed. For the QRHTP-LC model, if the timer indicates 00 (00 indicates timer off), it will still run for at least 1 minute (only when the pull cord is activated).

- Possible options: From 1 to 30 minutes with 1-minute steps, 00 disables the timer mode.
- The timer can also be set to Automatic Timer Mode.

Possible options:

- QRHT-LC and QRHTP-LC: If the humidity increases the RH sensor will take over until the humidity decreases. There is no over-run timer when this occurs.
- QRHTP-LC Only: When the pull cord is activated the timer will over-run by 10 minutes.
- All Models when using an external switch (i.e. light switch):
 - If the switch is activated for less than 3 minutes the run-on timer will not operate.
 - If the switch is activated for more than 3 minutes and less than 30 minutes the run on timer will be 1/3 of the time period for which the switch was activated.

Example: If activated for 3 minutes = 1 minute over-run, if activated for 15 minutes = 5 minute over-run.

- If more than 30 minutes the timer will over-run by 10 minutes. This is the maximum over-run period.

RELATIVE HUMIDITY MENU (QRHT-LC AND QRHTP-LC VERSIONS)

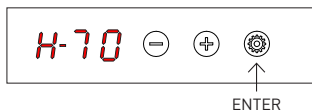

The fan will increase in speed when the Relative Humidity (RH) setpoint is exceeded.

- Possible options: From 00 to 90 with 5% steps. Setpoint range: 60, 65, 75, 80, 85, 90 or Automatic Intelligent Humidity mode (00 disables this operating mode).
- Automatic Intelligent Humidity Mode: The timer is disabled in RH mode as the operation is fully automatic.
- Factory setting: 70%.

OPERATING INFORMATION MENU (QRST-LC, QRHT-LC, QRHTP-LC versions)

This menu will be activated when any key is pressed for more than 3 seconds and released. This menu shows the running time (years, weeks, days and hours), the instantaneous flow rate,

the relative humidity (QRHT-LC version only) and if there are any errors.

- Total Run Time & Test:
 - Product operating time (motor running):
 - Years: shows how long the device has been running, from 00 to 99 years. Sample display "Y-02" = 2 years.
 - Weeks: From 00 to 52. Sample display "W-01" = 1 week.
 - Days: From 00 to 07. Sample display "d-03" = 3 days.
 - Hours: From 00 to 23. Sample display "h-18" = 18 hours.
- Therefore, this menu shows the years, months, weeks, days and hours that the product has been in operation since its installation and, in this example, it would be: 2 years + 1 week + 3 days + 18 hours. The display would look like this:

Y-02
W-01
d-03
h-18

Relative humidity reading [%] (QRHT-LC and QRHTP-LC versions): If the relative humidity reading [%] is less than 45%, it is shown as H-Lo.

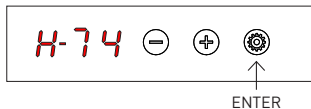

- Errors:
 - E-00 = No error
 - E-01 = Motor error
 - E-02 = Electronic error

RISKS TO CONSIDER

- Incorrect installation or use is a safety risk.
- Operating temperatures: indicated on the fan marking plate. Do not exceed these limits. The air to be moved must be free of chemical particles that could damage the product materials.
- Foreign bodies: make sure that no objects or mounting materials that can be sucked in or dislodged are left in the fan area. If the fan is connected to ducts, check that they are clean before connecting.
- Electrical hazards: do not exceed the values indicated on the marking plate. Check the electrical connection and make sure it matches the product instructions before switching on the fan for the first time.
- The unit needs to be connected to an appropriately protected circuit as per local regulations.
- Mechanical risk: The fan must be installed on a solid base, level with the correct direction of airflow. Use any accessories necessary to ensure proper, safe assembly and do not leave any parts unassembled as this could compromise the safety of the product. Do not touch the blade when in motion.

TRANSPORT, HANDLING

The packaging for this device has been designed to withstand normal transport conditions and to protect it from dirt. The device must only be transported in its original packaging, otherwise it may be damaged or warped. Do not accept any device that is not in its original packaging or that shows signs of having been tampered with. Avoid impact and dropping. Do not place excessive weight on top of the packaging.

MAINTENANCE

Before handling the device, make sure that it is disconnected from the mains, even if it is switched off. The device should be inspected regularly in order to avoid the accumulation of dirt. How often inspection is required will depend on the working conditions. Clean the humidistat with a dry cloth or Hoover. Make sure that these sensors are free of any kind of dirt.

END OF LIFE DISPOSAL



The WEEE directive and our commitment to future generations oblige us to recycle.

■ Please do not forget to dispose of all leftover packaging materials in the appropriate recycling bins.

The extract fan consists mainly of steel and plastic. The parts should be separated for recycling into the following categories:

- Steel and iron
- Plastics
- Electronic scrap materials

Due to our policy of continuous innovation and improvement envirovent reserves the right to alter products specification and appearance without notice.

We want to hear from you Your feedback is important to us as we strive to improve our products, services, and overall customer experience. Please email us to help us serve you better: feedback@envirovent.com

WARRANTY

We appreciate you choosing this quality envirovent product. We are confident that you will be delighted with the performance of the system and the resulting improvement in air quality in your home after it has been installed.

The envirovent QURO range is covered by a parts only 3-year warranty. Please note that conditions and ex-

clusions apply to the warranty which can be found at www.envirovent.com/warranty

Your unit serial number

What should I do if I have a problem?

If you encounter any problems with your unit, please fee free to call us on **01423 810 810**.

envirovent

envirovent Ltd
Harrogate West Business Park
Unit 1 Bardner Bank
Killinghall
Harrogate
HG3 2SP

01423 810 810
info@envirovent.com

www.envirovent.com

Ref. 9023139601
ENV1534

