

envirovent®

Infinity Extract Fan

Designed to Perform. Built to Last.

WC, Bathroom & Kitchen Fan



infinity



EnviroVent has been continually refining Filterless extract technology since it was invented 20 years ago, which has reduced social housing landlord's extractor fan maintenance costs by tens of millions of pounds. The Infinity model has been specifically designed and future-proofed to meet the requirements for existing and newbuild homes as whole-dwelling ventilation rates increase.

Guaranteed for longer than any other fan

The Infinity is designed and manufactured in the UK for the rigours of Social Housing where there is a need to remove moisture and improve indoor air quality for all in the dwelling over the long term with minimal maintenance.

Infinity has been designed for longevity and engineered with sustainable components to substantially reduce maintenance and life-cycle costs, ensuring minimum energy consumption. Guaranteed to last longer than any other fan with an incredible 8 year no quibble, warranty, the Infinity offers the lowest life-cycle costs on the market.



no quibble,
8 year warranty.
no strings attached.

the facts

Choose the EnviroVent Infinity and you only need to maintain it every 8 years

Over the years this technology has been proven to save Social Landlords tens of millions of pounds in fan maintenance costs

Datalogging and variable speed control as standard.

the result



Features & Benefits



Just some of the reasons why you should choose the Infinity



Datalogging function

Enables the collection of data such as the total running time at both speeds, the time in which the fan has spent in periods of increased humidity and the energy that has been used



Variable speed control

Ability to vary the speed of the fan for more control and to reach increased airflows



Patented cyclone separation technology

For maximum performance to control moisture and humidity



Pullcord as standard

Can be switched to boost mode with the use of the pullcord for odour control



Removable impeller. No filter.

For hassle-free, rapid and safe cleaning



Whisper quiet running

Eliminates one of the biggest complaints about noisy fans



Exchangeable cartridge system

Provides the lowest ever lifecycle costs to save housing providers millions of pounds in maintenance and replacement fees. The Filterless Infinity should never end up on a landfill site



Future-Proofed to Comply

Meets the airflow requirements of a typical dwelling



Ultra low energy consumption

Long trouble free life, less costs



Manufactured in the UK

Supporting our local economy, lowering the carbon footprint



Intellitrac® humidity tracking control

No need for user intervention, the Filterless Infinity reacts quietly to reduce high humidity before condensation can start to occur



8 year renewable warranty*

High quality for peace of mind, saving time, money and hassle. Reducing the impact on landfill sites too

For details on meeting PAS2030/2035 please contact EnviroVent

*Unit must be in warranty during service and cartridge change

Cyclone Separation Technology

1

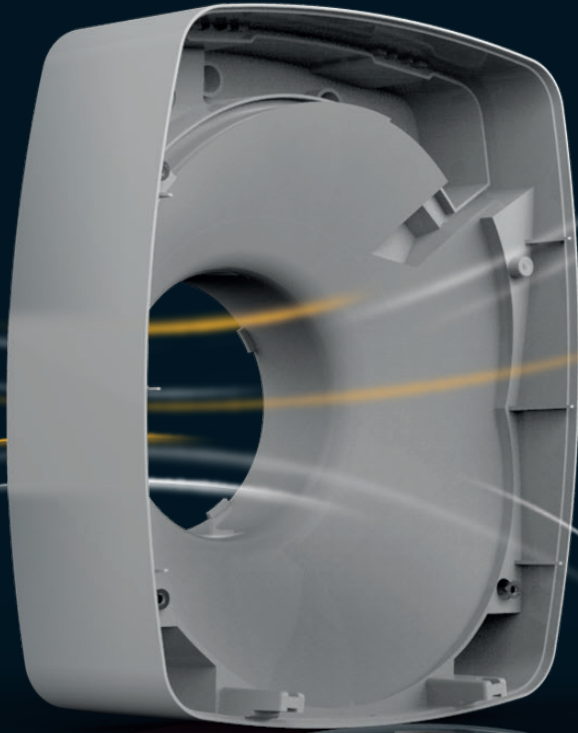

2

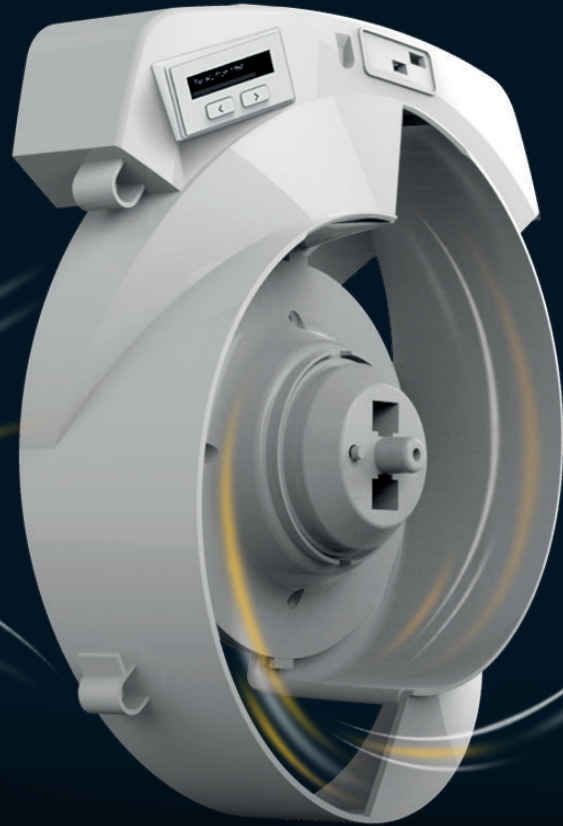

3



8

Precision engineered, allowing us to offer a 8 year warranty

We are absolutely confident that we can offer an 8 year no quibble maintenance-free warranty because we have been running an accelerated life test programme for nearly 20 years on the Infinity's predecessor - the original EnviroVent Filterless Fan.

Our R&D teams are continually testing and improving this technology to make it perform even better for longer. Following extensive testing and research we have further engineered the airflow of the Infinity with exact precision to achieve the optimal efficiency out of the highest quality bearings. The stylish front grille allows the air to pass through with the least possible resistance to achieve the quietest performance.

Accept no imitations.

The technology behind the Infinity

The Infinity ensures that all particles, humidity and dust in the air are drawn into the fan and extracted outside the property, without the need for filters that can become clogged. This enables the fan to deliver the maximum of performance to control moisture and humidity using the lowest energy consumption.

Cyclone Separation Technology

- 1 Air is expelled through robust rear chamber
- 2 Air is thrown outwards through a dual powered expansion chamber and allowed to expand out to atmosphere
- 3 Easy clean impeller
- 4 Air is drawn through the front grille

Datalogging function & variable speed control

The Datalogging function enables the collection of data such as the total running time at trickle and boost speeds, the time in which the fan has spent in periods of increased humidity and the energy that has been used.

The Infinity speed can be varied for more control and to achieve increased airflows.

Benefits:

- 1 Helps protect against disrepair cases
- 2 Reduce complaints about condensation and mould
- 3 Provides clarity on the running costs and energy usage





One Fan Fits All

The Infinity is ideal for WC, bathroom, kitchen and utility room installations, delivering high performance extract ventilation to meet the building regulations and beyond.

From simple through the wall installations, to in-line, window and ceiling installations, the Infinity fan fits all with the use of easy to install accessory kits.

For extra safety in bathrooms, a low voltage version is available.



Installation-Friendly

The Infinity has also been designed for the easiest installation ever:

IP rated cable entry socket

Easy commissioning

An IPX4 sealed chamber housing all electronics

The SELV version is supplied with a power supply unit incorporating a fixed fuse spur



Wall



Ceiling



Window

Datalogger and variable speed control as standard

Built into the central cartridge the Infinity Datalogger comes as standard enabling landlords to monitor running conditions, energy and operational life.

Also Included as standard is the variable speed control which enables greater flexibility when commissioning the fan speed.



Intellitrac[®] vapour tracking

Running continuously on trickle, the Infinity ensures that condensation and high humidity levels are kept at bay. No user intervention is required as the intelligent vapour tracking controls constantly monitor the average humidity.

As this rises and falls, the motor speed rises and falls in direct correlation. This controls condensation both quietly and efficiently, eliminating the problem of noisy extract fans and reducing the periods of time when the fan operates on maximum speed, saving energy.

Filter-free and fuss-free cleaning

4 step cleaning couldn't be simpler or safer:

There is a small magnet which deactivates the fan as soon as the front cover is removed. Once the cover is replaced the fan will continue to run as normal.

1 Remove the front cover



2 Clip out the impeller and wipe the fan clean



3 Wash the impeller in a sink**

4 Replace impeller and front cover



Airflow Performance* - 230V

Settings	Power [W]	Duty [l/s]
Bathroom Trickle	3	14
Bathroom Trickle+	4	21
Bathroom Boost	14	41
Kitchen Trickle	3	19
Kitchen Trickle+	4	22
Kitchen Boost	30	55

Airflow Performance* - SELV

Settings	Power [W]	Duty [l/s]
Bathroom Boost	14	37
Bathroom Trickle	3	14
Bathroom Trickle+	4	21

*Performance under free air condition (0Pa). These figures are based on factory settings & are subject to change when the datalogging & variable speed function are used. The power consumption is based on internal testing and has a tolerance of +/- 10%.

Running Costs

Bathroom & kitchen

Please scan our QR code to see the **annual running costs** of this product.



Or visit: envirovent.com/annual-running-costs

Technical data

Dimensions (mm)



Performance Curve*

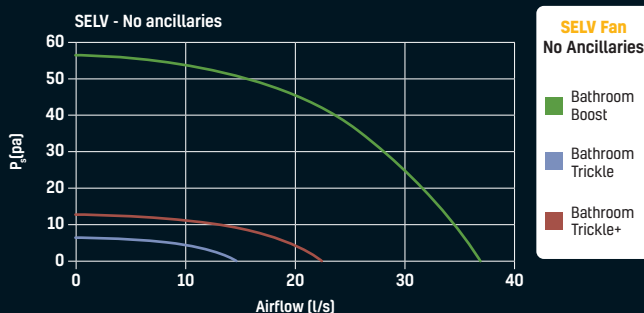
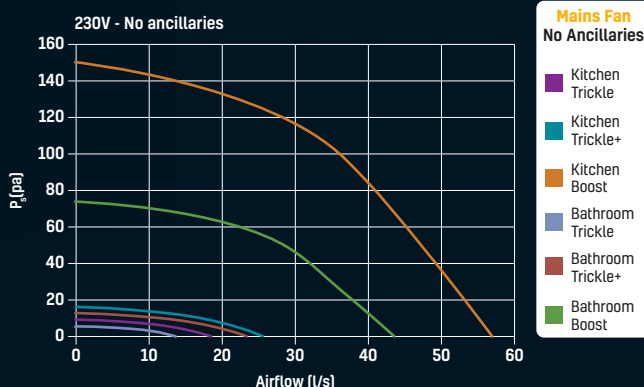

Models

MODELS	DESCRIPTION
INF-DL-230V	230V version with intellitrac® & pullcord
INF-DL-SELV	SELV version with intellitrac® & wireless boost switch
INF-DL-230V-RC	230V version with Intellitrac® & remote switch wire
INF-DL-SELV-RC	SELV version with Intellitrac® & remote switch wire
INF-DL-230V-WL	230V version with Intellitrac® & wireless controller
INF-DL-IL-W	230V inline version with Intellitrac® & wireless controller

Accessories

The Infinity is available in 230V or SELV format and can be wall, window or ceiling mounted with the use of the below kits.

ACCESSORIES	DESCRIPTION
1RD EFWAK	Wall kit
1AC EFCMBR	Ceiling mounting kit
INFWIK230V	230V window kit
INFWIK12V	SELV window kit
KITINLINEFAN	In-Line Fixing Kit

**Always refer to the installation instructions before carrying out maintenance.

envirovent®

Leaders in the manufacture of innovation
and sustainable ventilation

EnviroVent Ltd
Harrogate West Business Park
Unit 1 Bardner Bank
Killinghall, Harrogate
HG3 2SP

T / 01423 810 810
E / enquiries@envirovent.com
W / www.envirovent.com

Due to our policy of continuous innovation and improvement, EnviroVent reserves the right to alter products specification and appearance without notice.

E&OE | MKT ENV1016 - V6 - 06/03/2025

Copyright © EnviroVent Ltd 2025



Follow us on
facebook



Find us on
LinkedIn



Watch us on
Youtube



Follow us on
Instagram

