

**envirovent**<sup>®</sup>

# MIV<sup>®</sup> Loft Mounted Unit Multiple Input Ventilation

Whole House Ventilation



# MIV® LOFT MOUNTED UNIT

Whole House Multiple Input Ventilation

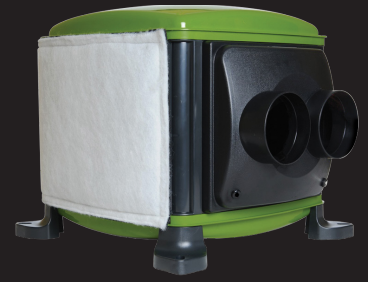

## About

Building on the principles of the hugely successful and established EnviroVent PIV systems, the MIV® Loft Mounted Unit has been designed and developed to launch a totally new and innovative technology - Multiple Input Ventilation (MIV®).

## Features & Benefits

- ▶ Ultra Low Watt DC motor technology
- ▶ Sealed for life ball bearings
- ▶ Loft or external air supply
- ▶ Integral Hours Run Meter (as standard)
- ▶ Integral intelligent comfort heater (as standard)
- ▶ Optional remote controlled boost facility
- ▶ 5 year warranty
- ▶ Quiet operation
- ▶ Provides all year round quality filtered air
- ▶ Reduces surface condensation
- ▶ Reduces musty odours
- ▶ Enhances heat distribution
- ▶ Takes advantage of the benefits of solar gain in the loft space
- ▶ Benefits asthma sufferers by reducing dust mites and mould spores
- ▶ Reduces Radon levels
- ▶ Easy to install



## Energy Saving Benefits

### ✔ Minimum Energy Consumption

Powered by an Ultra Low Watt Brushless DC Motor, the MIV® Loft Mounted Unit utilises the latest technology to ensure minimum energy consumption and long term trouble free life.

### ✔ Solar Gain

The unit takes maximum advantage of the benefits of solar gain from within the loft space - the natural accumulation of heat from the sun on bright days. Temperatures in the loft space are on average 3°C higher than outside, which results in a relative saving of around 150 Watts per day in an average modern family home. This equates to approximately 10% of annual heating costs.

### ✔ Heat Distribution

Warm air accumulates at ceiling level. This air can be up to 7°C higher than the internal air at ground level. By introducing an almost imperceptible air supply into the dwelling from the loft space, the MIV® Loft Mounted Unit helps to redistribute heat around the home and thus reduce space heating costs.

### ✔ No Need to Open Windows

To reduce humidity and condensation during the heating season, significant energy loss occurs by opening windows. By installing an MIV® Loft Mounted Unit and providing filtered air to the home humid air is displaced without opening windows and thus making significant savings to the occupier.



## How is it Different?

Instead of providing just a single source of air into a property, usually located in a hallway or landing, the MIV® Loft Mounted Unit has the ability to supply filtered air via multiple inputs into areas with greater requirements for ventilation. Highly efficient, inputs can be situated into or adjacent to rooms affected by increased levels of humidity, such as the kitchen, bathrooms and other wet rooms.

Diffusers can also be located in bedrooms or living spaces that suffer from particularly bad condensation or in the bedroom of an asthma sufferer to reduce the level of humidity and therefore the house dust mite population - a known trigger for allergies and asthma.



## Unique Mini Diffuser

Available with the MIV® Loft Mounted Unit is the stylish energy saving diffuser, providing an innovative alternative to standard ceiling vents.



## Make it MIV Multi Zone Destratification

Warm air accumulates at ceiling level and is normally lost through windows and extract fans. This air can be up to 7°C higher than the internal air at ground level.

By introducing air supply into multiple rooms, the MIV® Loft Mounted Unit redistributes heat around the home by pushing the heat back down and keeping the convection currents moving to reduce space heating costs. By saving only 1 degree of heat this multi-zone destratification may reduce fuel bills by up to 10%.



## Intelligent Remote Control (Optional)

Remote control incorporating five mode settings: trickle, medium, high, boost and auto is available. Auto-mode enables or disables the heater.



## Upgrade to MIV® Air Source



### Solar Gain & Summer Cooling

The MIV® Air Source takes maximum advantage of the benefits of solar gain from the loft space throughout the year. Solar gain is the natural accumulation of heat from the sun on bright days.

Temperatures in the loft are on average 3°C higher than outside and as the unit draws air from the loft and delivers it into the property, this results in a saving of around 500 Kilowatts of energy per year in an average family home - equating to significant savings in annual heating costs. Going beyond traditional input ventilation, the MIV® Air Source has the facility to source cooler air from outside the building when the temperature in the loft space rises above 25°C.

Detecting the rise in temperature, the unit starts to draw air from atmosphere via a temperature controlled diverter mechanism. This not only provides efficient perception cooling into the property during warmer weather, but also maintains the required level of ventilation continuously throughout the year. This facility is greatly beneficial for properties affected by high levels of Radon.



## Annual Running Costs

Please scan our QR code to see the **annual running costs** of this product.



Or visit:  
[envirovent.com/  
annual-running-costs](http://envirovent.com/annual-running-costs)

## Comparisons against other household appliances

### MIV® Loft Mounted Unit

HOUSEHOLD APPLIANCE	TIME REQUIRED TO CONSUME THE ANNUAL ENERGY USAGE
FRIDGE FREEZER	19.7 DAYS
42" TV (VIEWING TIME)	19.6 DAYS
100W LIGHT BULB	14.3 DAYS
HOME PC	4.6 DAYS
GAMES CONSOLE	4.6 DAYS
IRON	41 HOURS
TUMBLE DRYER	17 HOURS
COLDFILL DISHWASHER	17 LOADS

### MIV® Air Source

HOUSEHOLD APPLIANCE	TIME REQUIRED TO CONSUME THE ANNUAL ENERGY USAGE
FRIDGE FREEZER	20 DAYS
42" TV (VIEWING TIME)	20 DAYS
100W LIGHT BULB	14.6 DAYS
HOME PC	4.7 DAYS
GAMES CONSOLE	4.7 DAYS
IRON	41 HOURS
TUMBLE DRYER	17 HOURS
COLDFILL DISHWASHER	17 LOADS



## Technical Specification

### Product

Whole house multiple input ventilation system for properties with a loft space.

### Applications

#### MIV® Loft Mounted Unit

Sited in a loft space, the unit delivers air to multiple rooms of a property to provide displacement ventilation in order to improve indoor air quality and reduce condensation related problems.

#### MIV® Air Source

During warmer months of the year when the temperature in the loft space exceeds 25°C, the MIV® Air Source has the additional facility to draw air from atmosphere via a temperature controlled diverter mechanism. This provides efficient perception cooling into the property and maintains the required level of ventilation continuously throughout the year.

### Performance & Sound Levels (as installed figures)

#### MIV® Loft Mounted Unit

Incoming Air Temp. (°C)	Fan Speed Setting	Specific Fan Power [SFP]	Airflow [l/s]	Power Usage [W] (4)	Outlet Noise dB(A) @3m
<19 (1) (2)	Trickle	0.24	15	4	<15
	Medium	0.22	20	4	<15
	Large	0.21	26	6	<15
	Boost	0.25	34	9	<15

#### MIV® Air Source

Incoming Air Temp. (°C)	Fan Speed Setting	Specific Fan Power [SFP]	Airflow [l/s]	Power Usage [W] (4)	Outlet Noise dB(A) @3m
<19 (1) (2)	Trickle	0.16	19	3	<15
	Medium	0.18	24	4	<15
	Large	0.23	30	7	<15
	Boost	0.31	36	11	15
>25 (3)	Trickle	0.28	26	7.3	-
	Medium	0.31	32	9.8	-
	Large	0.33	38	12.6	-
	Boost	0.36	44	15.7	-

- 1 The unit performs in 'condensation control mode' at air temperatures below 19°C
- 2 At above 19°C the unit increases airflow rates per setting by 10%
- 3 The unit performs in 'summer by-pass mode' at air temperatures at or above 25°C
- 4 Power usage with heater disabled

### Installation

Full installation guide is enclosed with all products; or sent separately in advance - if required. The unit is pre-wired with a standard length of 230V cable suitable for connection to the mains and a low voltage cable suitable for connection to the auto heater switch.

### Construction

ABS plastic body.

### Motor

Incorporates the Ultra Low Watt DC motor technology with sealed for life ball bearings designed to operate continuously at a pre-set 'background' rate.

### Fan

Is a Ø146mm dual inlet forward curved centrifugal fan.

### Filter

Is a synthetic fibre based filter made to ISO coarse 65% standard in accordance with EN779 standard ratings. The filter should conform to all European Union and US fire classification standards (e.g. DIN 53438-F1 and UL900-class 2) and be self-extinguishing.

**Servicing / Maintenance**

EnviroVent recommend that units should be serviced annually to maintain optimal performance and that filters should be checked regularly and cleaned as and when required.

**Warranty**

The EnviroVent MIV, and AirSource Loft Mounted units are covered by a parts only 5-year warranty. Please note that conditions and exclusions apply to the warranty which can be found at [www.envirovent.com/warranty](http://www.envirovent.com/warranty).

**Integral 'Intelligent Low Temperature' Comfort Heater**

During cold periods, the unit is capable of maintaining the incoming air temperature consistently at 10°C. The integral heater element is manufactured in a solid tubular sheath material.

**Accreditations**

Conforms to the requirements of the UK Building Regulations and the Technical Standards for Ventilation.

**Conforms to requirements of the EC council directives**

Relating to Electromagnetic Compatibility and Electrical Safety (LDV and EMC). CE Marked.

**Performance Curves**

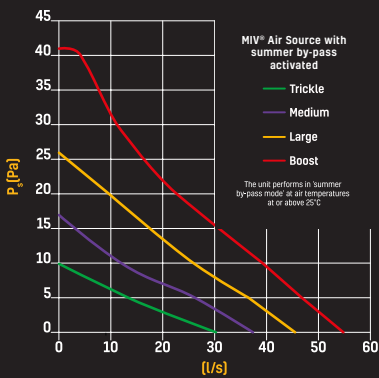
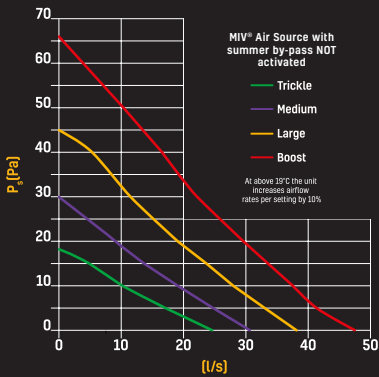
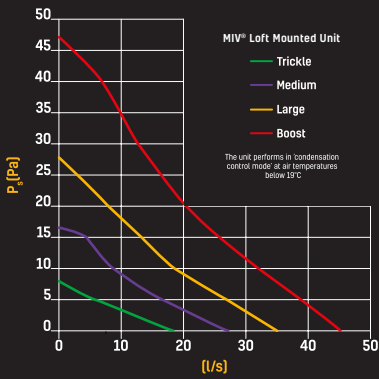

**Dimensions (mm)  
MIV® Loft Mounted Unit**

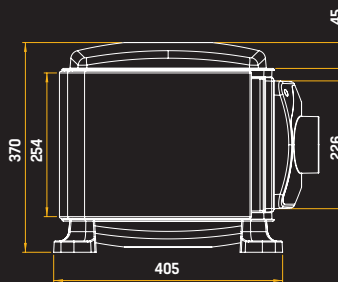
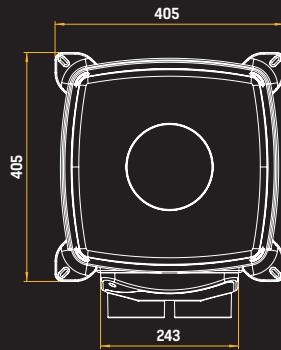
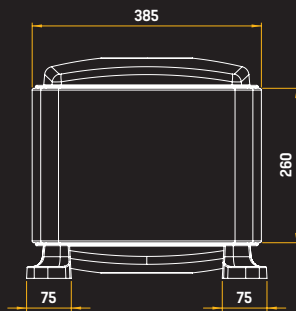
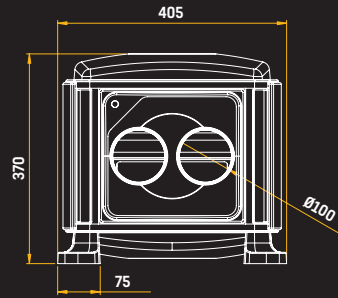

**Dimensions (mm)  
MIV® Air Source**

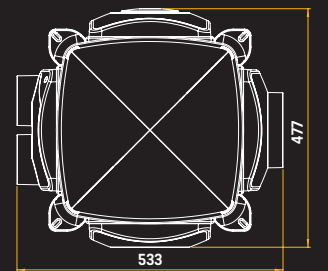
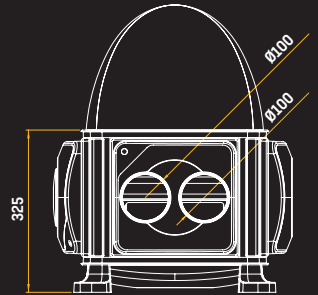
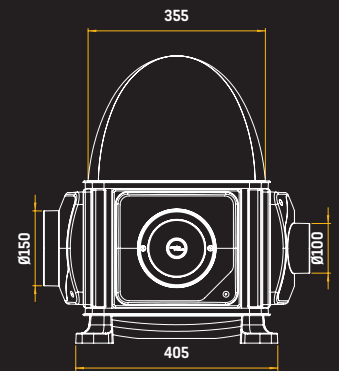
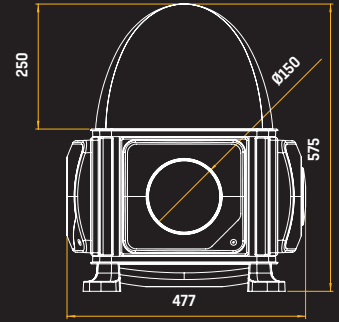

# envirovent®

Leaders in the manufacture of innovation and sustainable ventilation

EnviroVent Ltd  
Harrogate West Business Park  
Unit 1 Bardner Bank  
Killinghall, Harrogate  
HG3 2SP

T / 01423 810 810  
E / enquiries@envirovent.com  
W / www.envirovent.com

Due to our policy of continuous innovation and improvement, EnviroVent reserves the right to alter products specification and appearance without notice.

E&OE | MKT ENV450 - V2 - 02/12/2025

Copyright © EnviroVent Ltd 2025



Follow us on  
**facebook**



Follow us on  
**twitter**



Watch us on  
**Youtube**



Follow us on  
**Instagram**



Follow us on  
**Pinterest**



Find us on  
**LinkedIn**

