

envirovent

Eco dMEV+ LC
Eco dMEV+ LC17V



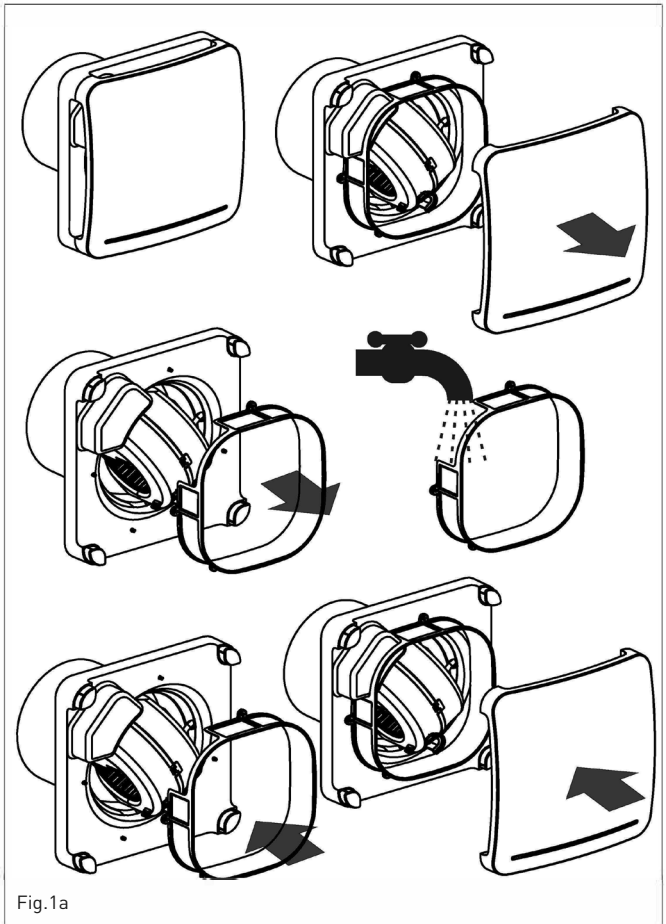

Fig.1a

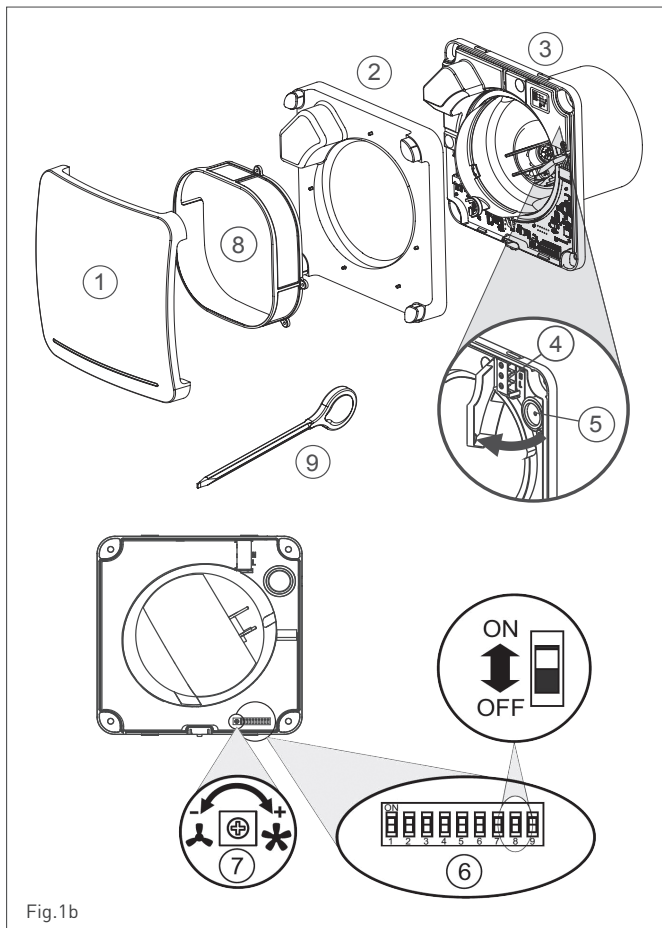
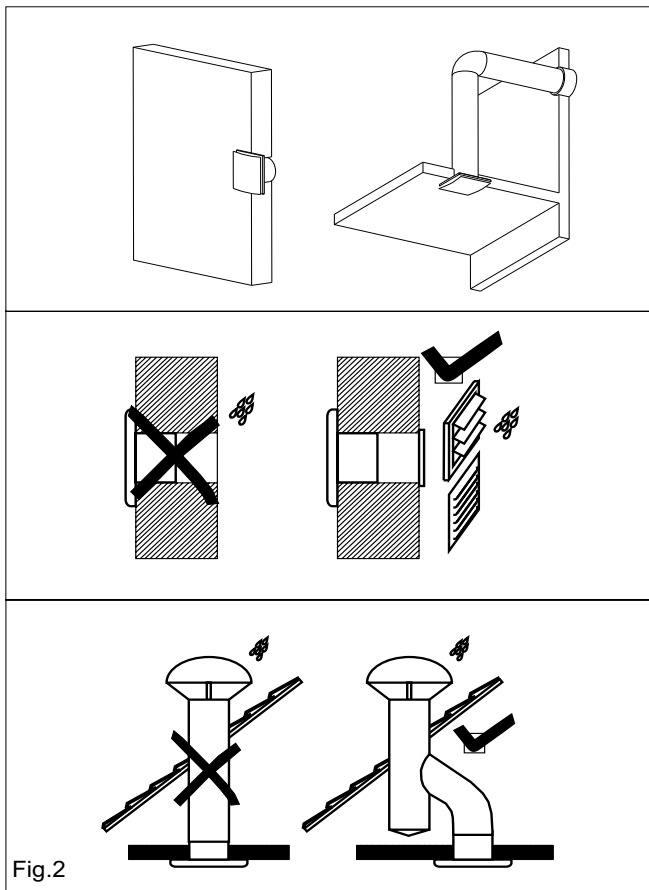
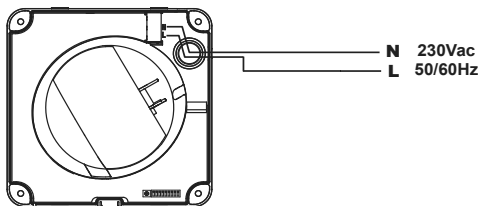

Fig.1b



Eco dMEV+ LC



Eco dMEV+ LC17V

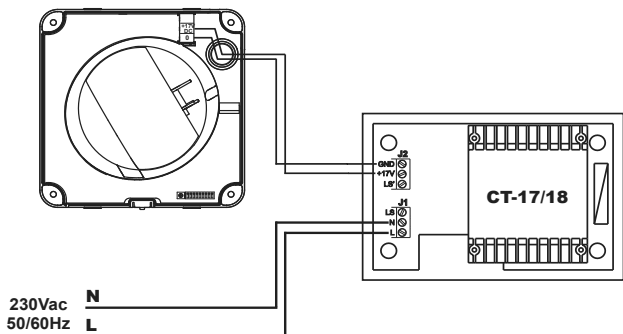
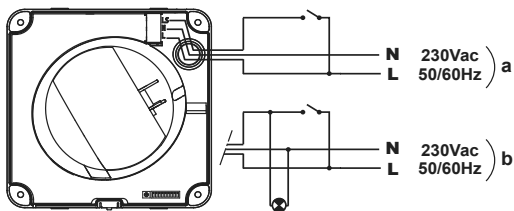

Fig.3

Eco dMEV+ LC



Eco dMEV+ LC17V

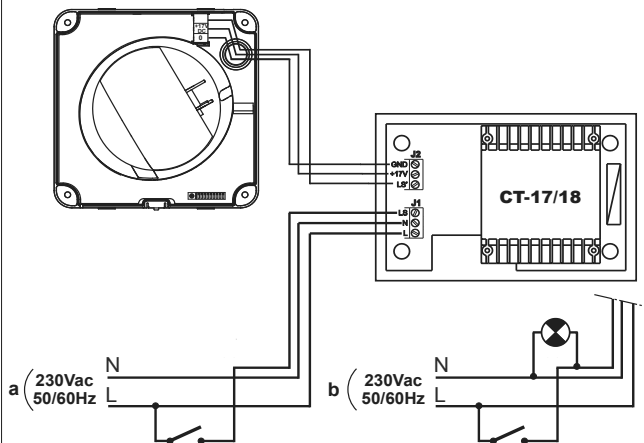
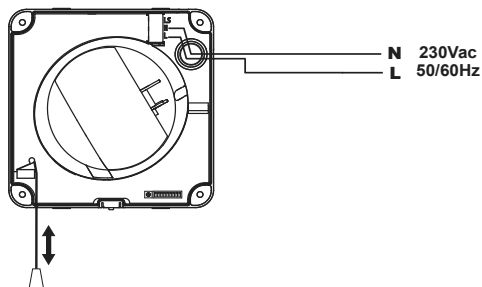

Fig.4

Eco dMEV+ LC



Eco dMEV+ LC17V

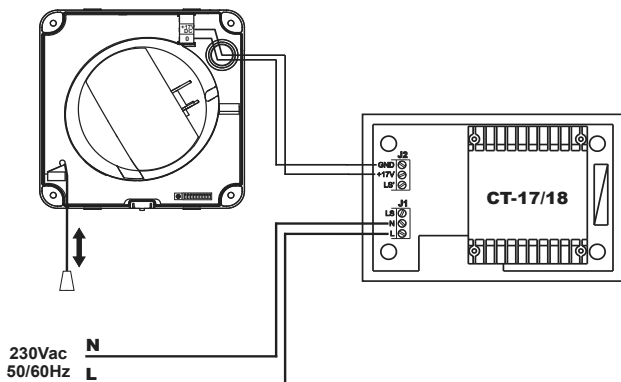

Fig.5

Eco dMEV+ LC Centrifugal Extractor Fans

The Eco dMEV+ LC extractor fan range is manufactured to the highest standards of production and quality as laid down by the international Quality Standard ISO 9001. All components have been checked and every one of the final products will have been individually tested at the end of the manufacturing process.

On receipt of the product we recommend that you to check the following:

1. That it is the correct model.
2. That the details on the rating label are those you require: voltage, frequency... The installation must be carried out in accordance with the electrical standards in force in your country.

This appliance can be used by children aged from 8 years and above and persons with reduced physical, sensory or mental capabilities or lack of experience and knowledge if they have been given supervision or instruction concerning use of the

appliance in a safe way and understand the hazards involved. Children shall not play with the appliance. Cleaning and user maintenance shall not be made by children without supervision.

INSTALLATION

IMPORTANT: Before installing and wiring the unit, ensure that the main supply is disconnected.

Fig. 1b:

1. Front grille
2. Protection cover
3. Support
4. Connection terminals
5. Cable entry
6. Dip switches
7. Potentiometer for speed adjustment
8. Air filter
9. Setting tool

The Eco dMEV+ LC is suitable for wall or ceiling mounting and can either extract directly to the outside or via an individual ducting system (see Fig. 2). Make a hole in the wall or ceiling of diameter 105 mm.

If the unit is to be installed with individual ducting, use a standard duct of diameter 100 mm.

Remove the front grille (1) and the protection cover (2).

The unit can be mounted on the wall or ceiling using the 4 plastic plugs and the screws provided.

Ensure that there are no obstructions to the airflow and that the impeller turns freely.

Introduce the mains cable through the cable entry (5) and fix it to the wall.

Connect the electrical wiring as set out below and then mount the protection cover and the front grille.

ELECTRICAL CONNECTION

The Eco dMEV+ LC is an extractor designed for a single phase supply, with voltage and frequency as indicated on the rating plate of the unit. The units are manufactured with double electrical insulation (Class II) and therefore they do not need an earth connection. The electrical installation must include a double pole switch with a contact clearance of at least 3 mm.

The electrical cable must enter the Eco dMEV+ LC through the cable entry (5).

Once the cable has been introduced proceed using the electrical wiring diagram applicable to the selected model.

OPERATION

The Eco dMEV+ LC is an extractor fan designed to operate continuously at low speed (adjustable) and constant volume with the facility to be set to

high speed (fixed) through the following functions depending on the version: an external switch live or light switch (**S, T and HT versions**); the humidity sensor (**HT and HTP versions**); the internal pull cord switch (**HTP version**); or the PIR detector (**DT version**).

The extractor can also be used for intermittent operation with adjustable speed at installation.

In both cases the speed setting is done when installing the extractor, with the potentiometer (7) placed on the electronic PCB (fig.1b).

The trickle speed is adjusted at 8 l/s as a default (factory setting). A variety of speeds can be adjusted by the potentiometer (7) ranging from 4 l/s, with a maximum speed of 18 l/s.

The selection between continuous operation and intermittent operation is done with the dip-switch 5:
 Continuous operation: ON
 Intermittent operation: OFF

ATTENTION: In intermittent operation, mount the backdraft shutter on the fan outlet.

ECO DMEV+ S LC

1. Continuous operation only on trickle setting (Fig. 3).

Once the air volume is set the fan is connected to the mains and the unit will operate continuously at this air volume.

2. Continuous operation on trickle with ability to boost at high speed.

The Eco dMEV+ S LC is connected to an external switch or light switch.

When the switch is closed, the fan runs at full speed until the switch opens again (light off):

Fig.4a- Wiring diagram to boost the fan with the light switch.

Fig.4b- Wiring diagram to boost the fan with a separate switch

3. Intermittent operation: With dip-switch 5 set to OFF the extractor runs at the preset speed when the switch is closed:

Fig.4a- Wiring diagram to switch on the fan with the light switch.

Fig.4b- Wiring diagram to switch on the fan with a separate switch.

Start-up timer function:

In this operation, the "start-up timer function" allows you to delay the extractor start-up for a period of 50 seconds. So that, for example, the fan does not switch on if the usage time of the bathroom is less than 50s. If you exceed the 50s, the fan switches on, and when the light switches off, runs the time set by the timer.

This function is selected with the dip- switch 2.

ECO DMEV+ T LC

This model is provided with an adjustable over-run timer.

The selection of the run on time is done with the dip-switches 6 and 7: setting between 1, 5, 15 and 30 minutes

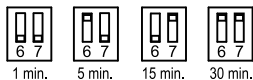

Factory setting: 1 minute

1. Continuous operation: The timer allows the fan to continue to operate in high speed for the selected period after the switch has been turned off.

Fig.4a- Wiring diagram to boost the fan with the light switch.

Fig.4b- Wiring diagram to boost the fan with a separate switch

2. Intermittent operation: The timer allows the fan to continue to operate for the selected period after the switch has been turned off (fig.4a and 4b).

Start-up timer function:

In this operation, the "start-up timer function" allows the fan to delay the start-up for a period of 50 seconds. So that, for example, the fan does not switch on if the usage time of the bathroom is less than 50s.

If you exceed the 50s, the fan switches on, and when the light switches off, runs on for the time set by the timer.

This function is selected with the dip- switch 2.

ECO DMEV+ HT LC

Models provided with an electronic humidity sensor which can be adjusted from 60% to 90 % RH (relative

humidity) and with a timer, adjustable between 1 and 30 minutes.

The selection of desired humidity level is done with the dip-switches 8 and 9: setting between 60, 70, 80 and 90 %RH:



The selection of the run on time is done with the dip-switches 6 and 7: setting between 1, 5, 15 and 30 minutes:



CONTINUOUS OPERATION

- Automatic operation (fig.3): the extractor is connected to the main supply with only two wires. The extractor operates continuously at the setting trickle speed. When the humidity level in the room is higher than the set level the fan is boosted to high speed. When the humidity drops below the selected level and after the selected period set on the timer the fan automatically returns to trickle.
- Automatic operation with the facility to override the humidity sensor and make the extractor run in boost by means of an external switch (fig.4a) or the light switch

(fig.4b), when the humidity level in the room is lower than the selected level. In this case, the extractor operates in high speed for the selected period set on the timer after the light switch has been switched off, and then goes back in low speed unless the humidity level exceeds the set point.

ATTENTION: When the humidity rate is above the selected value, the automatic option takes precedence over the manual.

SPECIFIC RECOMMENDATIONS

- If the humidity is always above 90% RH, the fan will always run at full speed.
- If the humidity in the room is always less than 60%, the fan will only operate at trickle speed when running in automatic operation.

If the fan never runs at boost:

- The setting of the humidity sensor is at maximum. Change the setting
- The level of humidity in the room is below 60% RH

If the fan always runs at boost

- The setting of the humidity sensor is at minimum. Change the setting
- The level of humidity in the room is above 90% RH

INTERMITTENT OPERATION

Automatic operation:

The extractor is connected to the main supply with only two wires (fig.3). The humidity sensor causes the extractor to operate automatically when the humidity level in the room is higher than the set level. The extractor will stop automatically when the humidity drops below the selected level (-5% or +10%) and after the selected period set on the over-run timer.

“Interval” functions:

This function is useful when the extract fan is installed in very wet conditions (near the sea) or the ambience exceeds the set level for a very long time. To prevent the fan running for hours without stopping, the “Interval” function allows the fan to switch off automatically one hour after it began to run. The extractor keeps switched off during the set time for interval function. If the humidity level is still above the set level when the time interval is over, the extract fan switches on again and runs for one hour.

When, on the contrary, the extract fan never switches on because the humidity level is always very low or it is improperly installed (above heating appliance, behind a door, in an area with no air movement) with the Interval function activated, the fan switches on automatically for 1 hour and then it keeps switched off during

the set time for interval function. This function causes the fan to run whatever the humidity level.

To adjust the pre-set time for interval function, use the dip-switches 3 and 4.

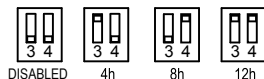

Automatic operation with external switch to override the extractor:

The extractor is connected to the main supply with three wires (fig.4a y 4b).

Operation as previous “Automatic operation”, with the facility to override the humidity sensor by means of the light switch when the humidity level in the room is lower than the selected level. In this case the extractor continues to operate for the selected period of time (over-run timer) after the light switch has been switched off.

ATTENTION: When the humidity rate is above the selected value, the automatic option takes precedence over the manual and the unit cannot then be switched off using a switch.

Start-up timer function:

In this operation, the “start-up timer function” allows you to delay the extractor start-up for a period of 50 seconds. So that, for example, the fan does not switch on if the usage time of the bathroom is less than 50s. If you exceed the 50s, the fan switches

on, and when the light switches off, runs the time set by the timer.

This function is selected with the dip-switch 2.

ECO DMEV+ HTP LC

Eco dMEV+ LC version similar to **HT** model, fitted with an internal pull cord switch to operate the boost when the humidity level is below the set point (fig.5)

When switching off the internal pull cord switch, the fan continues to operate on boost for the time set by the timer, then runs on trickle speed, unless the humidity level exceeds the set point.

ECO DMEV+ DT LC

Models provided with a PIR (passive infra-red) detector (movement detected with a maximum distance of 4 metres) and with an adjustable "run on" timer (1 to 30 minutes).

The selection of the run on time is done with the dip-switches 6 and 7: setting between 1, 5, 15 and 30 minutes:



1 min.



5 min.



15 min.



30 min.

1. Continuous operation:

The extractor operates continuously at the setting trickle speed. When the extractor detects a movement the fan is boosted to

high speed during the selected period set by the over-run timer and then automatically returns to trickle speed (fig.3).

2. Intermittent operation:

The unit starts automatically when a movement is detected and the unit continues to operate for the selected period set on the over-run timer (fig.3).

FACTORY SETTINGS

Interval function: OFF

Humidity sensor: 60%HR

Timer: 1 minute

Start-up timer function: OFF

Continuous operation: ON

MAINTENANCE

IMPORTANT: DISCONNECT FROM THE MAINS SUPPLY BEFORE CARRYING OUT ANY MAINTENANCE

The Eco dMEV+ LC extract fan is supplied with a plastic filter.

Performance depends on cleaning frequency and thus we recommend checking the filter regularly and cleaning as and when required.

The Eco dMEV+ LC extract fan must always be operated with the filter fitted. Using the extract fan without the filter invalidates the warranty.

The external surface of the fan only requires periodical cleaning using a

cloth lightly impregnated with a soft detergent.

AFTER SALES SERVICE

We recommend you not to try to dismantle or remove any other parts than those mentioned as any tampering would automatically cancel the envirovent guarantee.

If you detect any fault, contact our dedicated Technical team on 01423 810 810.

END OF LIFE DISPOSAL



EEC legislation and our consideration of future generations mean that we should always recycle materials where possible; please do not forget

to deposit all packaging in the appropriate recycling bins. If your device is also labeled with this symbol, please take it to the nearest Waste Management Plant at the end of its servicable life.

envirovent reserves the right to alter specifications without notice.

WARRANTY

We appreciate you choosing this quality envirovent product. We are confident that you will be delighted with the performance of the system and the resulting improvement in air quality in your home after it has been installed.

The envirovent ECO-DMEV+LC range is covered by a parts only 2-year warranty. Please note that conditions and exclusions apply to the warranty which can be found at www.envirovent.com/warranty

Your unit serial number
.....

What should I do if I have a problem?

If you encounter any problems with your unit, please fee free to call us on **01423 810 810**.

envirovent

envirovent Ltd
Harrogate West Business Park
Unit 1 Bardner Bank
Killinghall
Harrogate
HG3 2SP

01423 810 810
info@envirovent.com

www.envirovent.com

Ref. 9023045207
ENV1533

