

TECHNICAL DATA SHEET

ATMOS® Dual | Whole House Positive Input Ventilation Unit



PRODUCT

Whole house positive input ventilation system for properties with a loft space, providing ventilation to improve air quality and reduce condensation related problems.

APPLICATIONS

The ATMOS® Dual unit is manufactured in the UK and installed in properties with a loft space to meet the Building Regulations Approved Document F.

ATMOS® Dual units supply filtered air from the loft space into multiple areas of a property at a continuous rate via two ceiling mounted diffusers. The system provides ventilation in order to improve indoor air quality and reduce condensation related problems taking maximum advantage of the benefits of solar gain from within the loft space.

INSTALLATION

A full installation guide is enclosed with all products, or sent separately in advance if required. For fitment in 3 floor properties above 4.5m, ATMOS® units should be fitted with a fire rated diffuser and wired to shut off on detection of smoke. The unit is pre-wired with a standard length of cable for connection to the 230V mains supply and a low voltage cable for connection to the auto comfort heater switch. On W and A versions the low voltage cable is reconfigured as a 0-10V input. Duct from the unit to the diffuser is supplied as standard along with a fixing kit.

INTEGRAL 'INTELLIGENT' COMFORT HEATER

During cold periods, the unit is capable of maintaining the incoming air temperature consistently at 10°C. The integral heater element is manufactured in a solid tubular sheath material.

CONTROLS

At installation the unit will be set by the installer using the integrated control panel to run at one of the 4 fixed speeds [1,2,3, or 4] depending on the size and occupancy of the property. The unit will run continuously all year round on this setting. An integral hours run meter is fitted on all units for monitoring of operational life and verification of usage.

Optional controls:

Model **ATL-WD** - these units are supplied with a wireless remote control. The user can view the current status of the unit, increase or decrease airflow as required and enable/disable the Auto comfort heater.

Model **ATL-AD** - these units are app-enabled. Once the user activates the boost switch in the myenvirovent app, the airflow is boosted for 20 minutes as standard before returning to the commissioned setting. Other functions within the myenvirovent app include: Airflow setting, Filter indicator, Hours run meter, Summer mode control, Auto comfort heater enable/disable.

0-10V variable control input for use with the AIRSENS is available on both W and A versions.

ANNUAL RUNNING COSTS

Please scan our QR code to see the annual running costs of this product or visit:
envirovent.com/annual-running-costs



PERFORMANCE & SOUND LEVELS

Incoming Air Temp. [°C]	Fan Speed Setting	Specific Fan Power (SFP)	Airflow [l/s]	Power Usage [W] [3]	Outlet Noise dB(A) @3m
<19 [1] [2]	1	0.24	15	4	<15
	2	0.22	20	4	<15
	3	0.21	26	6	<15
	4	0.25	34	9	<15

- Above 19°C the unit increases airflow rates per setting by 10%.
- The unit switches to Summer Mode at air temperatures at or above 25°C.
- Power usage with Comfort Heater disabled.

PRODUCT CODES

Code	Description
ATL-D	ATMOS Air Dual
ATL-WD	ATMOS Air Dual - Wireless Remote Control Unit
ATL-AD	ATMOS Air Dual - App Control Unit

*ATMOS Inline units are a designed specifically for properties with air restricted loft spaces to draw fresh air from outside throughout the year

TECHNICAL DATA SHEET

ATMOS® Dual | Whole House Positive Input Ventilation Unit

CONSTRUCTION

Durable ABS plastic body.

MOTOR

Incorporates DC motor technology with sealed for life ball bearings designed to operate continuously at a pre-set 'background' rate.

FAN

Ø146mm dual inlet forward curved centrifugal fan.

FILTER

The unit has a synthetic fibre based filter made to ISO Coarse 65% in accordance with the ISO 16890 standard.

MAINTENANCE

EnviroVent recommend that filters are checked regularly and replaced as required. Areas with high particulate matter for example industrial areas, or higher-grade filters will become clogged quicker and will need replacing more frequently. Spare and replacement filters must be genuine EnviroVent parts.

WARRANTY

The EnviroVent ATMOS Dual Loft units are covered by a parts only 10-year warranty. Please note that conditions and exclusions apply to the warranty which can be found at www.envirovent.com/warranty

ACCREDITATIONS

Conforms to the requirements of the UK Building Regulations and the Technical Standards for Ventilation.

Conforms to requirements of the EC directives relating to Electromagnetic Compatibility and Electrical Safety (EMC and LVD).
CE Marked.

SPARES & ANCILLARIES

Spares & Ancillaries	Code
Replacement coarse particle filter (ISO coarse 65%)	FILTERPIV-COARSE
Replacement medium particle filter (ePM10 50%)	FILTERANC-MEDI
Replacement fine particle filter (ePM2.5 50%)	FILTERANC-FINE
Replacement coarse particle filter including carbon (ISO coarse 65% including carbon)	FILTERANC-COARSE+C
EnviroVent diffuser	1DIFEVLSML1
Ø125 Kit for 3 floor installation, fire diffuser & ducting	KIT-PIV-SMOKE-125
Smoke alarm for the above units	1ACSMOKEALARM-KIT
AirSens® CO2*	AIR-CO2
AirSens® VOC*	AIR-VOC
AirSens® RH*	AIR-RH

*W and A units only

E&OE | MKT ENV646 - V4 - 19.06.25

DIMENSIONS (MM)

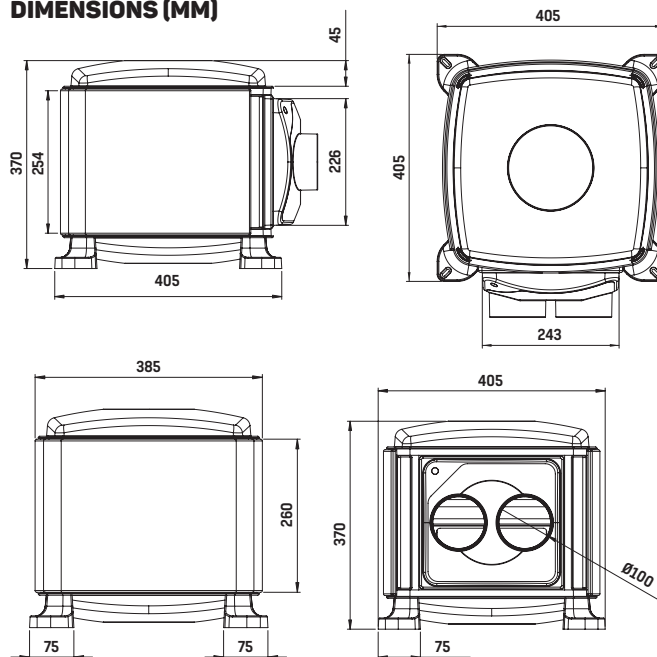

PERFORMANCE CURVE

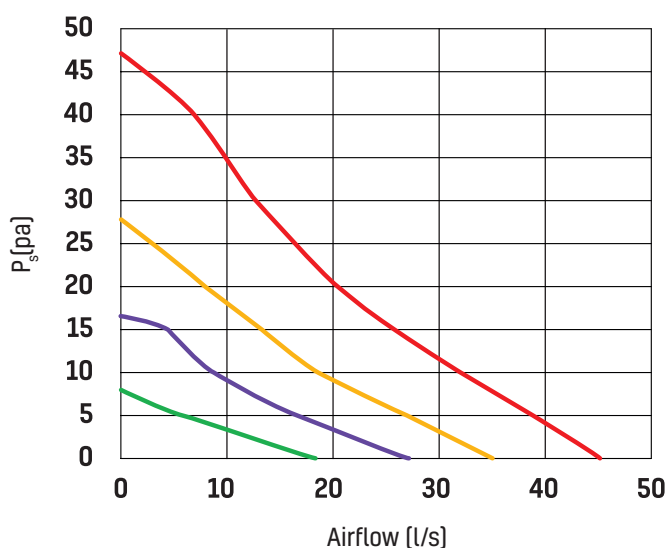

Performance curve results are measured at free air, based on the unit running below 19°C and exclude ancillaries