

envirovent

SILENT DESIGN

Instruction leaflet



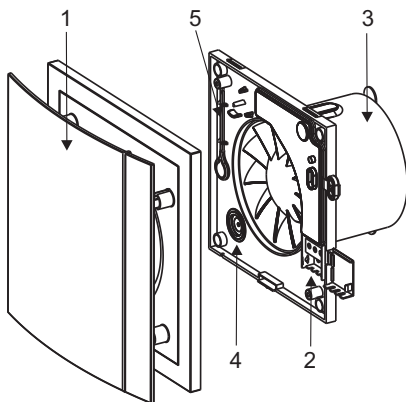

Fig. 1

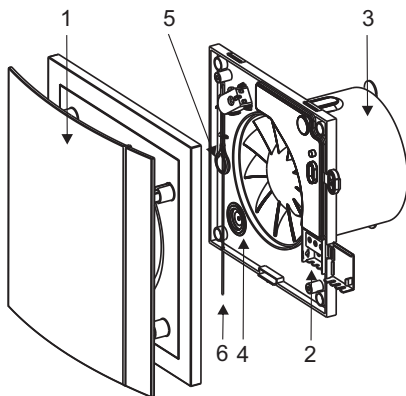
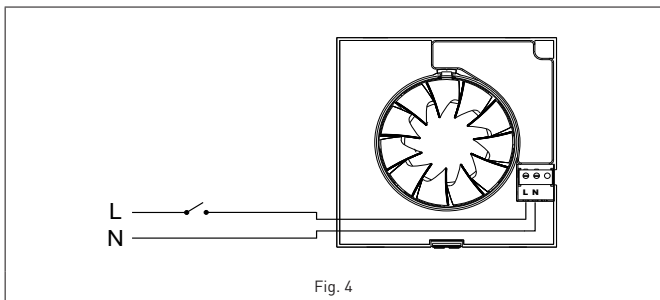
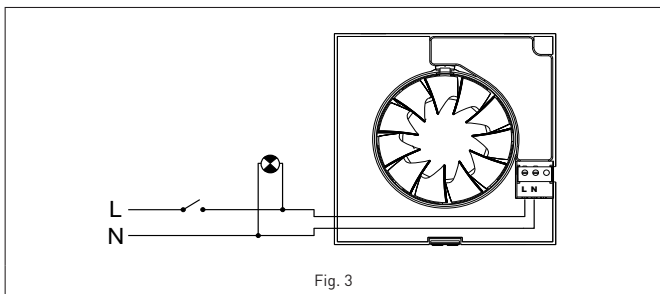
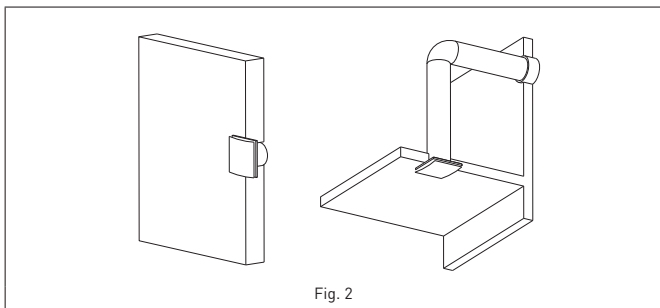

Fig. 1



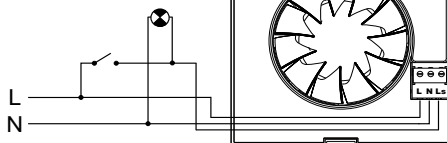

Fig. 5

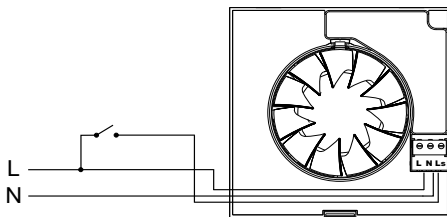
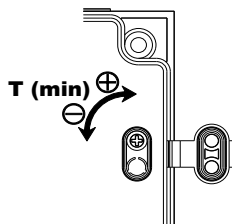

Fig. 6



SILENT T DESIGN

Fig. 7

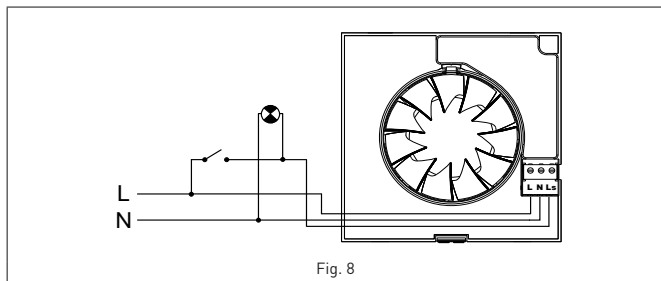

Fig. 8

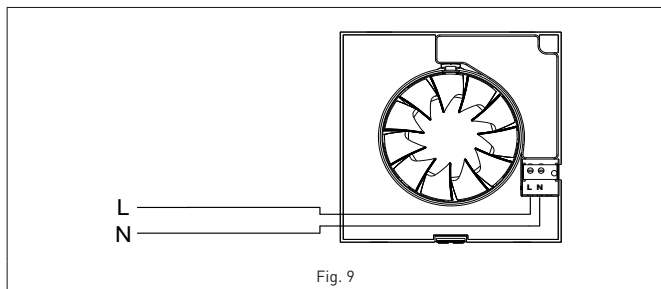

Fig. 9

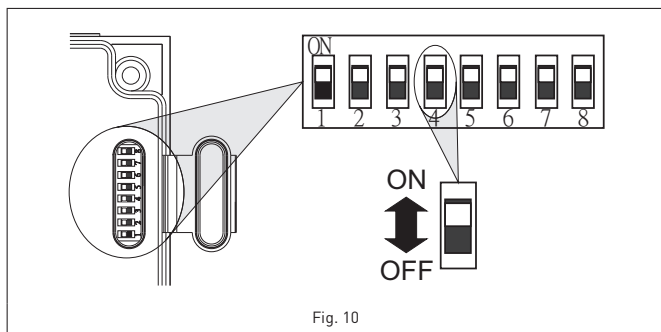

Fig. 10

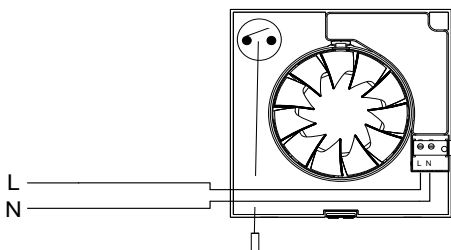
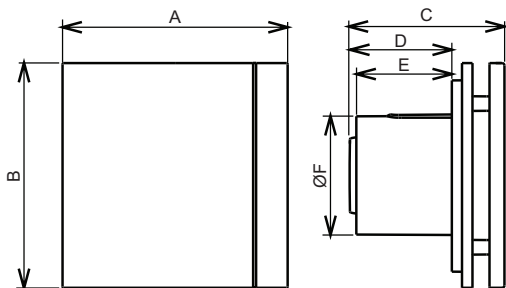

Fig. 11



	A	B	C	D	E	ØF
SILENT-100 DESIGN	188	188	130	84,6	79	98,9
SILENT-125 DESIGN	210	210	145	89	80	116
SILENT-150 DESIGN	247	247	179	112	95	146

SILENT DESIGN axial extractor fans

Please read this instruction booklet carefully before installing or starting up the product. It contains important information on personal and user safety measures to be followed whilst installing, using and carrying out maintenance work on the equipment. The SILENT DESIGN extractor fans have been manufactured following current technical safety regulations, production and quality standards as laid down by the international Quality Standard ISO 9001. All components have been checked and every one of the final products will have been individually tested at the end of the manufacturing process.

Check that the product is in perfect condition while unpacking. Make sure that the product corresponds to the one you have ordered and that the details on the instruction plate fulfil your requirements.

The installation and the disconnection device of the fixed installation used must be in accordance with the installation regulations in force in each country. Once the product has been installed, pass this booklet to the end user.

RECOMMENDATIONS

IMPORTANT: Before installing and wiring the unit, ensure that

the mains supply is disconnected.

Working ambient temperature for fan equipment should not be exceeded. Typically, this falls within -5°C to $+40^{\circ}\text{C}$, unless stated otherwise.

The spigot cannot be connected to a duct which is used to extract smoke from gas or any other fuel appliance.

The extractor must not be used in explosive or corrosive atmospheres.

If the SILENT DESIGN fan is operating in a room where there is a boiler or any other kind of combustion device that requires airflow to work, check that the

air inlets to the room are sufficient. This appliance can be used by children aged from 8 years and above and persons with reduced physical, sensory or mental capabilities or lack of experience and knowledge if they have been given supervision or instruction concerning use of the appliance in a safe way and understand the hazards involved. Children shall not play with the appliance. Cleaning and user maintenance shall not be made by children without supervision.

INSTALLATION (fig.1)

This fan is IP45 rated and it is suitable for application in zones 1 and 2 with RCD protection.

- 1- Protection grille
- 2- Connection terminals
- 3- Outlet with backdraught shutter
- 4- Cable entry
- 5- Screwdriver to adjust Timer and Hygrostat (not supply with S and P models)
- 6- Pullcord (P models)

The SILENT is suitable for wall or ceiling mounting and can either extract directly to atmosphere or via a ducted system (fig.2).

The unit can be mounted on the wall or ceiling using the 4 raw plugs and the screws provided. Make a hole in the wall or ceiling of diameter:

- SILENT-100 DESIGN: 105 to 107 mm.
- SILENT-125 DESIGN: 125 to 132 mm.
- SILENT-150 DESIGN: 160 to 158 mm.

If using the envirovent high rise wall kit, please refer to kit for core drill size

If the unit is to be installed in a ducted system, use the following standard diameter of duct:

- SILENT-100 DESIGN: 100 mm.
- SILENT-125 DESIGN: 125 mm.
- SILENT-150 DESIGN: 150 or 160 mm.

Ensure that there are no obstructions to the airflow and that the impeller turns freely.

Fix the extractor fan to the wall in such a way that it is not distorted in order to avoid noise generation or problems with the rotation of the impeller.

Make sure that the backdraught shutter opens freely and has not being

damaged in transit. Introduce the mains cable through the cable entry (4) and fix it to the wall.

Connect the electrical wiring as set out below and then mount the protection grille (1).

ELECTRICAL CONNECTION

The SILENT DESIGN is an extractor fan designed for a single-phase supply, with voltage and frequency as indicated on the rating plate of the unit. The units are manufactured with double electrical insulation (Class II) and therefore they do not need an earth connection.

The electrical cable must enter the SILENT DESIGN through the cable entry (4). The SILENT DESIGN must be connected to the electrical supply in accordance with local wiring regulations. Once the cable has been introduced proceed using the electrical wiring diagram applicable to the selected model.

SILENT S DESIGN

For these models, use the following diagrams:

Fig.3: Switching the extractor through the light switch.

Fig.4: To switch the fan through an independent switch.

SILENT T DESIGN

This model is provided with an adjustable over-run timer. The timer allows the fan to continue to operate for the selected period after the switch has been turned off (fig. 6).

Fig.5 shows how to connect the fan with timer utilising the same switch as for the lighting circuit.

To set the timer, turn the potentiometer on the printed circuit board as (fig. 7).

- To reduce the "run on" time, turn anticlockwise (min. 1 minute).
- To increase the "run on" time, turn clockwise (max: 30 minutes).

SILENT HT DESIGN

IMPORTANT: Do not remove the tape covering the humidity sensor located on the reserve of the grille.

Models provided with an electronic humidistat which can be adjusted from 60% to 90 % RH (Relative Humidity) and with a timer, adjustable between 1 and 30 minutes.

The desired humidity level and run on time are selected by means of 8 dip-switches placed on the printed circuit board, and easily accessible. Each dip-switch has two positions [ON (1) and OFF (0)] which are selected with the small plastic screwdriver supplied with the fan (fig.10):

The functions of these dip-switches are:

- Switch 1: "Interval" function selection (yes or no)

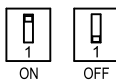

- Switches 2 and 3: Interval time settings between 4, 8, 12 and 24 hours

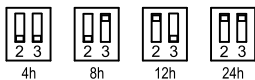

- Switches 4 and 5: Humidistat settings between 60, 70, 80 and 90%



- Switches 6 and 7: Over-run timer settings between 1, 5, 15 and 30 minutes



- Switch 8: Start-up timer function (yes or no)

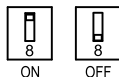

Automatic operation:

The extractor is connected to the main supply with only two wires. The humidistat causes the extractor to operate automatically when the humidity level in the room is higher than the set level. The extractor will stop automatically when the humidity drops below the selected level (-5% or +10%) and after the selected period set on the over-run timer.

"Interval" functions:

This function is useful when the extract fan is installed in very wet (near the sea) or the ambience exceeds the set level for a very long time. To pre-

vent the fan to run for hours without stopping, the "Interval" function allows the fan to switch off automatically one hour after it began to run. The extractor keeps switched off during the set time for interval function. If the humidity level is still above the set level when the time interval is over, the extract fan switches on again and runs during one hour. To select this function put the dip-switch 1 to position "ON".

To adjust the set time for interval function, use the dip-switches 2 and 3.

When, on the contrary, the extract fan never switches on because the humidity level is always very low or it is improperly installed (above heating appliance, behind a door, in an area with no air movement) putting the 1 dip-switch interval function to position "ON", the fan switches on automatically during 1 hour and then it keeps switched off during the set time for interval function. This function causes the fan to run whatever the humidity level.

To select this function put the dip-switch 1 to position "ON".

To adjust the pre-set time for interval function, use the dip-switches 2 and 3.

Automatic operation with external switch to override the extractor: The extractor is connected to the main supply with three wires.

Operation as previous "Automatic operation", with the facility to override the humidistat by means of the light switch when the humidity level

in the room is lower than the selected level. In this case the extractor continues to operate for the selected period of time (over-run timer) after the switch light has been switched off.

ATTENTION: When the humidity rate is above the selected value, the automatic option takes precedence over the manual and the unit cannot then be switched off using the pullcord.

Start-up timer function:

In this operation, the “start-up timer function” allows to delay the extractor start-up for a period of 50 seconds. So that, for example, the fan does not switch on if the usage time of the bathroom is less than 50s.

If you exceed the 50s and the humidity level in the room is below the selected level, the fan switches on, and when the light switches off, runs the time set by the timer.

This function is selected with the dip-switch 8.

Factory settings:

- Interval function: OFF
- Interval time: 4h
- Humidistat: 60%HR
- Timer: 1 minute
- Start-up timer function: OFF

SILENT P DESIGN

Models provided with on/off pullcord switch use the following wiring diagram:

Fig.11: Fan operating only with pullcord.

MAINTENANCE

Fan equipment should be electrically isolated and locked out before any work starts.

The extractor fan only requires periodical cleaning using a cloth lightly impregnated with a soft detergent.

END OF LIFE DISPOSAL



EEC legislation and our consideration of future generations mean that we should always recycle materials where possible; please do not forget to deposit all packaging in the appropriate recycling bins. If your device is also labeled with this symbol, please take it to the nearest Waste Management Plant at the end of its serviceable life.

AFTER SALES SERVICE

We recommend you not to try to dismantle or remove any other parts than those mentioned as any tampering would automatically cancel the envirovent guarantee.

If you detect any fault, contact our dedicated Technical team on 01423 810810.

WARRANTY

We appreciate you choosing this quality envirovent product. We are confident that you will be delighted with the performance of the system and the resulting improvement in air

quality in your home after the installation of the unit.

The envirovent Silent Design range is covered by a parts only 5-year warranty. Please note that conditions and exclusions apply to the warranty which can be found at www.envirovent.com/warranty.

Your unit serial number
.....

What should I do if I have a problem?

If you encounter any problems with your unit, please feel free to call us on **01423 810 810**.

envirovent

envirovent Ltd
Harrogate West Business Park
Unit 1 Bardner Bank
Killinghall
Harrogate
HG3 2SP

01423 810 810
info@envirovent.com

www.envirovent.com

Ref. 9023065503
ENV1536

