

# ATMOS® WALL

## Positive Input Ventilation for Flats & Apartments



### About ATMOS®

The ATMOS® WALL Unit is an energy efficient condensation-control unit for flats and apartments.

It introduces fresh, filtered air throughout the living space to transform a stagnant and stale atmosphere into a fresh, healthy and condensation free environment.

### Features & Benefits

- ▮ Reduces/eliminates surface condensation
- ▮ Quiet operation
- ▮ Helps to eliminate mould
- ▮ Stops streaming windows
- ▮ Minimises musty odours
- ▮ Improves air quality
- ▮ Benefits asthma sufferers
- ▮ Low running costs
- ▮ Exceptionally lightweight, just 5Kg
- ▮ Integral intelligent comfort heater (as standard)
- ▮ Ultra Low Watt DC motor technology
- ▮ ATMOS® Remote Control Boost version available
- ▮ App-enabled version available to connect to the myenvirovent App
- ▮ Compatible with the AirSens® range of Indoor Air Quality Sensors
- ▮ Extremely low profile, just 16cm
- ▮ 10 year guarantee\*

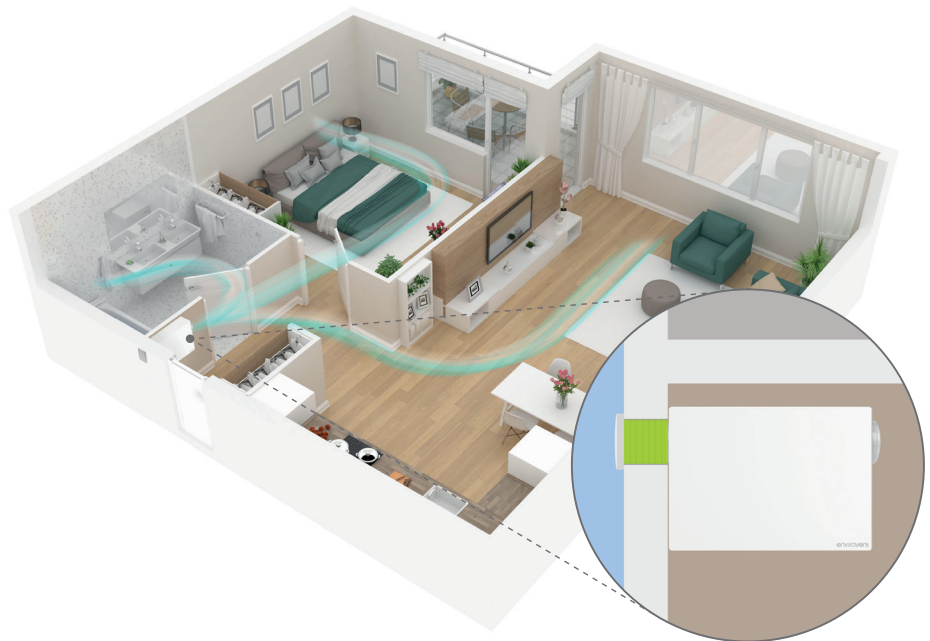

### Planet Friendly



### Energy Saving Benefits

#### ✔ Minimum Energy Consumption

ATMOS® WALL is designed with the latest low watt motor technology to ensure minimum energy consumption and long term trouble-free life.

#### ✔ Reduce Heat Loss

To reduce humidity and condensation during the heating season, significant energy loss occurs by opening windows. ATMOS® WALL provides fresh, filtered air into the home, displacing humid air reducing the need to open windows and mitigating heat loss.

#### ✔ The ATMOS® 10-Year Warranty\*

All products in the ATMOS® range come with our extended 10-year warranty\*.

### User Friendly



### myenvirovent App and Airsens®

*myenvirovent*

The ATMOS® WALL unit is available with the myenvirovent App (ATF-A), designed to offer total control of the unit from anywhere in the home at the touch of a button.

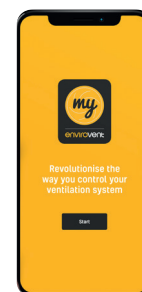

- Filter indicator
- Adjustable boost functionality
- Hours run meter
- Adjustable airflow
- Adjustable heater
- Control summer mode
- Enable or disable the heater

#### ✔ ATMOS® Remote Control

The ATMOS® units can be controlled with a remote control boost switch to increase the airflow when required (Order code -W).

\*10-year warranty is offered if this product is installed by EnviroVent.  
5-year warranty is offered if this product is not installed by EnviroVent.

## ✓ AirSens®

For those who like to keep an eye on air quality levels, AirSens® provides an easy-to-read colour-coded display, showing the current air quality at any time:

**Red** - Poor air quality

**Amber** - Medium air quality

**Green** - Good air quality

**Available in three models, AirSens® can detect and control levels of:**

- Carbon Dioxide (CO2)
- Volatile Organic Compounds (VOCs)
- Relative Humidity
- Temperature

ATMOS® WALL can be linked directly to the AirSens® sensor. This means it reacts automatically to changes in air quality, instantly supplying more fresh air into the property to maintain a healthy environment when needed.



## Install Friendly

ATMOS® WALL has been designed for utmost ease of installation in mind. With an extremely low profile of 16cm and weighing just 5kg, it can be wall or ceiling mounted with just four fixing points.

### Product Code

ATMOS® WALL Standard	ATF
ATMOS® WALL App-Enabled	ATF-A
ATMOS® WALL Remote Controlled Boost Switch	ATF-W

### Filter Options

- ISO ePM10 50%  
**FILTERWALL-MEDIUM (Default)**
- ISO ePM2.5 50%  
**FILTERWALL-FINE**
- ISO ePM2.5 50% including carbon  
**FILTERWALL-FINE+C**

## Health Benefits

With improved building features in our homes, such as cavity wall insulation, double glazing and draught proofing, 'natural ventilation' is prohibited. Stale air is trapped causing streaming windows, which ultimately leads to musty smells, dampness and mould growth. These mould spores are known allergens and become airborne at the slightest disturbance. The microscopic spores are then inhaled and can trigger respiratory problems such as asthma, dust allergies and hayfever.



The ATMOS® WALL Unit draws air into the dwelling from outside and filters it before being delivered into the property. Moisture laden air is diluted, displaced and replaced with clean, tempered and filtered air. This reduces surface condensation, which causes mould growth, providing a significant improvement in the health of asthma sufferers and general indoor air quality.

## ✓ Pre-Heater and Hours Run Meter

The integral pre-heater is designed to temper the incoming air during periods of low external temperatures. A sensor monitors incoming air and pulses the heater to ensure temperatures are held to pre-set minimums. Two independent safety cut-out devices shut down the heater in the event of fan failure. The heater facility is controlled independently from the fan by a conveniently positioned enable/disable switch (optional extra - code SWHEATER). For monitoring of operational life and verification of usage, an integral Hours Run Meter is fitted.

## Annual Running Costs

Please scan our QR code to see the **annual running costs** of this product.



Or visit:  
[envirovent.com/  
annual-running-costs](http://envirovent.com/annual-running-costs)

## Technical Specifications

**Applications** - The ATMOS® WALL mounted unit is manufactured in the UK and is designed for installation into flats and apartments to meet the Building Regulations Approved Document F. ATMOS units supply filtered air from outside into a central location within the property at a continuous rate. Air is supplied via a grille that is designed to maximise the efficiency of airflow. The unit provides ventilation in order to improve indoor air quality and reduce condensation related problems such as damp and mould.

**Motor** - Designed to operate continuously at a pre-set rate, incorporating DC motor technology with sealed for life ball bearings.

**Filter** - The unit has an ePM10 50% synthetic fibre based filter, tested in accordance with the ISO 16890 standard.

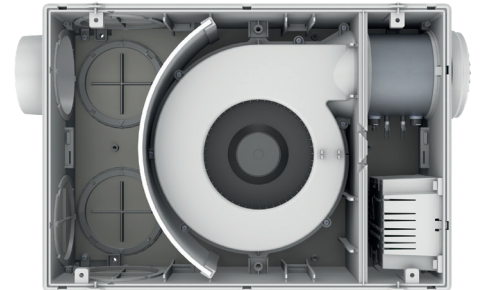

**Servicing / Maintenance** - EnviroVent recommend that filters are checked regularly and replaced as required. Areas with high particulate matter for example industrial areas, or higher-grade filters will become clogged quicker and will need replacing more frequently. Spare and replacement filters must be genuine EnviroVent parts. Any old components may be returned for recycling.

**Standard Functions** - Integral 'Intelligent Low Temperature' comfort heater. Designed to temper the air during periods of low external temperatures.

**Controls** - At installation, the unit will be set by the installer using the integrated control panel to run at one of the 4 fixed speeds (1,2,3,4) depending on the size and occupancy of the property, a variable speed option is also available. The unit will run continuously all year round on this setting. An integral hours run meter is fitted on all units for monitoring of operational life and verification of usage.

### Optional controls:

**Model ATF-W** - These units are supplied with a wireless remote control. The user can view the current status of the unit, increase or decrease the airflow as required and enable/disable the auto comfort heater.

**Model ATF-A** - These units are app-enabled. Once the user activates the boost switch in the myenvirovent app, the airflow is boosted for 20 minutes (default time period) before returning to the commissioned setting. Other functions within the myenvirovent app include: Airflow setting, Filter change indicator, Hours run meter, Auto comfort heater enable/disable.

0-10V variable control input for use with the AIRSENS® is available on both W and A versions.

**Warranty** - Covered by a 10 year warranty, if installed by EnviroVent. If this product is not installed by EnviroVent, 5-year warranty is offered.

**UK Building Regulations** - Conforms to the requirements of the UK Building Regulations and the Technical Standards for Ventilation.

Conforms to requirements of the EC and UK directives.

**Accreditations** - CE and UKCA Marked.

## Dimensions (mm)

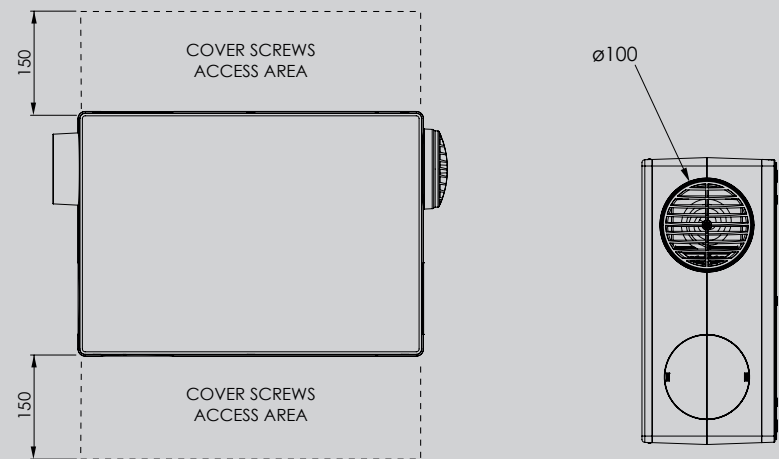
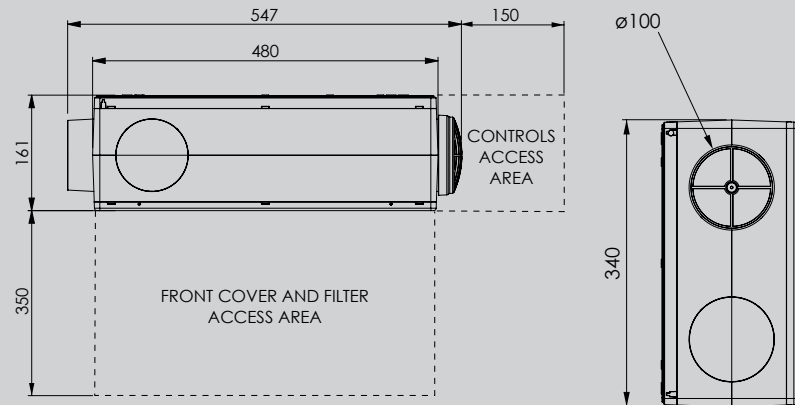

## Performance Curve

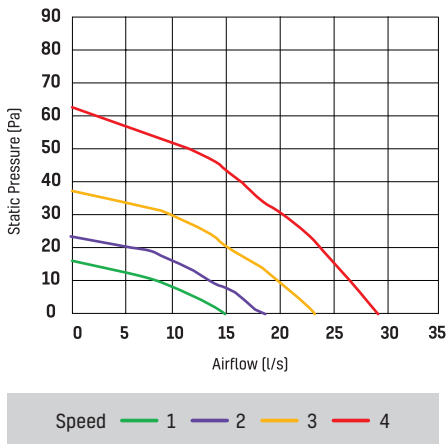

Performance curve results are based on the unit running below 19°C and exclude ancillaries.



E&OE | MKT ENV536 - V3 - 26.02.25