

envirovent®

Dual technology providing intelligent ventilation for the demands of today's world

SILENT DUAL







SILENT DUAL

The SILENT DUAL is an autonomous and intelligent extractor fan for bathrooms and WCs. It automatically adjusts its performance according to the environment and ventilation requirements via two sensors: a presence detector and a humidity sensor. Easy to install with just 2 wires.

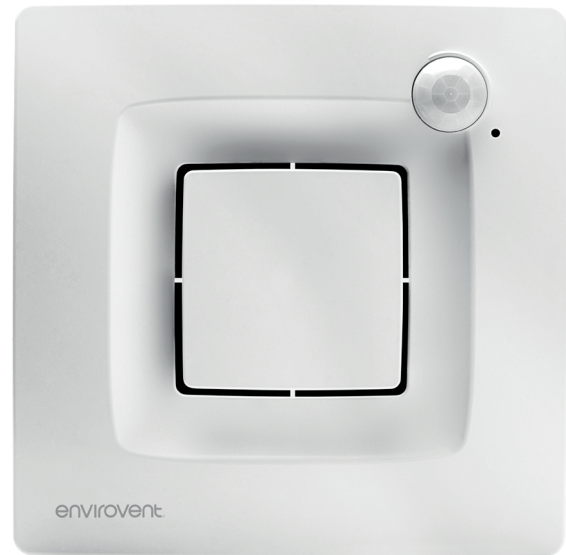

FEATURES



DUAL FUNCTION

Intermittent or Continuous

SILENT DUAL provides optimum versatility to be programmed as either an intermittent or continuous running fan.

Intermittent Mode

In intermittent mode the fan starts automatically when it detects a slight increase in humidity.

As humidity rises and falls, the motor speed tracks the humidity in direct correlation until the humidity level has fallen below the set threshold, ensuring quiet and efficient operation. For sudden peaks in humidity, the fan operates in boost mode.

In intermittent mode, the fan also automatically starts (75% of the maximum speed) when movement is detected and will continue to operate for the set period selected by the adjustable 'run-on' timer.

Over-run Timer

There are two settings available for the over-run timer: 2 minutes (for bathrooms less than 4m²) and 15 minutes (for bathrooms over 4m²).

Continuous Mode

In continuous running mode, the motor speed operates the same as intermittent, however instead of coming to a complete stop, the fan continues to operate on trickle speed (43% of maximum speed).

DUAL SENSING

The SILENT DUAL operates automatically when it detects movement (via the PIR) or rises in humidity levels and activates a pre-set mode to achieve the lowest energy consumption and the lowest noise level.

DUAL CONNECTION

Direct two-wire connection (L, N) for ease of installation.



DUAL INLETS

The SILENT DUAL has dual inlets for enhanced aerodynamic performance. Air is directed via the front and side panels, achieving similar performance to a traditional front grille but in a stylish and slim-line design to deliver greater pressure at low flow rates.

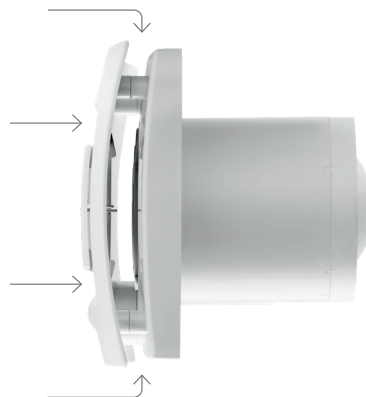

Self-adjusting technology to create the perfect environment

Depending on the configuration of the operating mode Intermittent (I) or Continuous (C)

IF NO PRESENCE DETECTION
OR INCREASE IN HUMIDITY
Instant RH < average ambient RH
NO detection

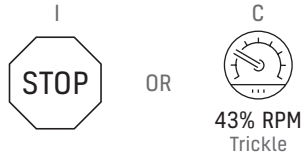

PRESENCE DETECTION (PIR)

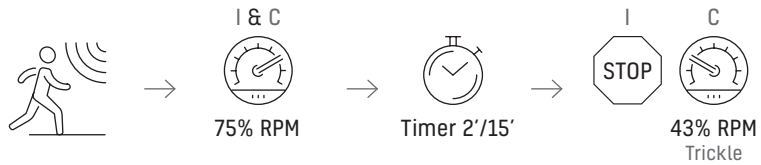

SUDDEN CHANGE IN HUMIDITY
Instant RH < average ambient RH
"sudden change"



SLIGHT CHANGE IN HUMIDITY
Instant RH < average ambient RH
Humidity Tracking Mode

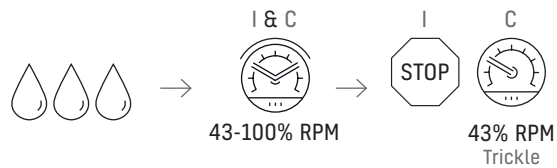

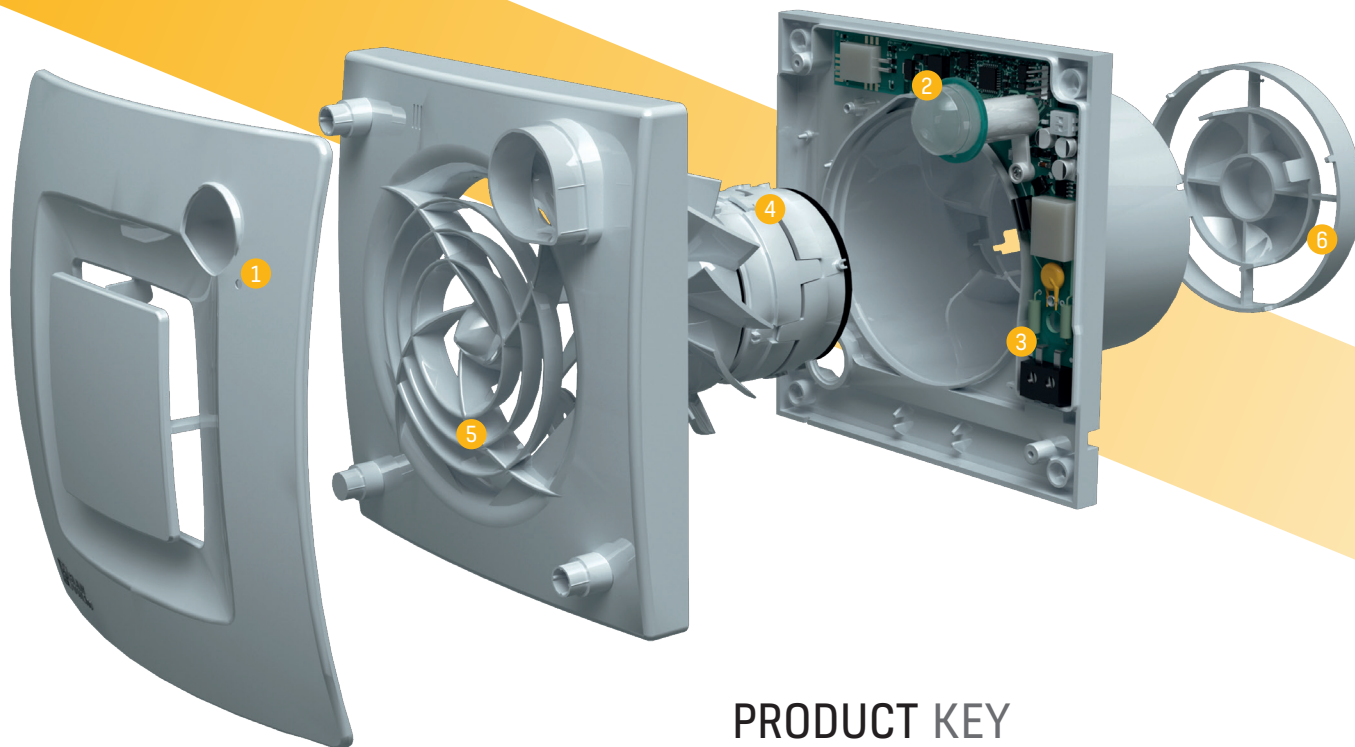

PRODUCT KEY

- 1 On-Off Indicator**
Incorporates an LED indicator to display on-off mode.
- 2 Presence Detector (PIR)**
Integrated presence detector with a wide detection angle.
- 3 Protected Electronics**
The Bi-material cover guarantees an IP45 rating of the electronic board and connections.
- 4 Silent-Block**
Motor mounted on a silent-block to reduce vibrations and sound level.
- 5 Grille**
Front grille with aerodynamic design to optimize airflow and improve performance.
- 6 Backdraft Shutter**
Removable backdraft shutter with airflow guide vanes to improve aerodynamic performance.



Clean Air Thinking

Find out more about the SILENT DUAL by scanning the QR code to see how it can improve the air quality in your property or home.



INTELLIGENCE & EFFICIENCY

The SILENT DUAL incorporates an intelligent algorithm to automatically adjust its settings according to the environmental conditions, without the need for user interaction. The motor is commissioned to achieve the required flow rate, minimising the electricity consumption and noise levels to meet the exact ventilation requirement.



Intelligent thinking, no user interaction.



DUAL BY
NAME,
DUAL BY
NATURE

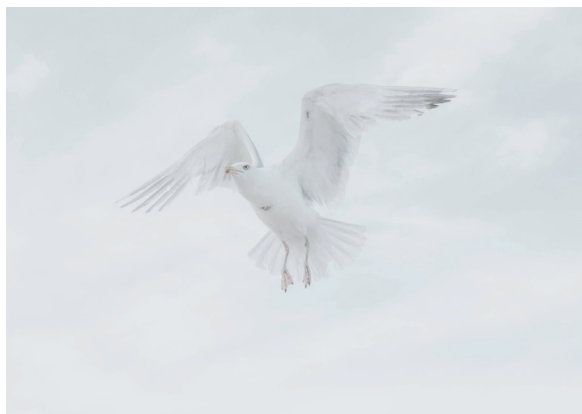

TECHNICAL SPECIFICATION

PRODUCT

The SILENT DUAL is an intelligent and self-adjusting axial extract fan designed to operate with very quiet noise levels, supplied in 220-240V suitable for WCs and bathrooms. The fan has been designed to operate in either intermittent or continuous running mode with a PIR detector, humidity sensor, backdraft shutter and airflow guide vanes as standard.

APPLICATION SUITABILITY

The SILENT DUAL can be wall or ceiling mounted to meet the Building Regulations - Part F (England), Scottish Building Standards and Part K (Northern Ireland).

INSTALLATION

The SILENT DUAL has been designed for ease of installation with a 2-wire connection (L, N). The units are manufactured with double electrical insulation (Class II) and do not require an earth connection. Full installation guide is enclosed with all products; or sent separately in advance if required.

CONTROLS

The SILENT DUAL is designed to operate either continuously at low speed or in intermittent mode. In intermittent mode, the fan will automatically start when it detects either a rise in humidity, via the humidity sensor or movement, via the PIR detector. In continuous running mode, the fan operates in the same way, however continues to run on the low background trickle rate when no humidity or movement is detected.

MOTOR

Speed-adjustable AC motor assembled on silent elastic blocks and fitted with ball bearings for enhanced working life. 220-240V 50Hz.

FAN

The impeller is axial flow type.

SERVICING/MAINTENANCE

The fan only requires periodic cleaning using a cloth soaked with a soft detergent.

WARRANTY

The EnviroVent Silent Dual units are covered by a parts only 5-year warranty. Please note that conditions and exclusions apply to the warranty which can be found at www.envirovent.com/warranty

COMPLIANCE

CE Marked.

PERFORMANCE

MODEL 	SILENT DUAL		
	BOOST	PIR + TIMER	CONTINUOUS
SPEED (RPM)	2200	1670	910
MAXIMUM POWER ABSORBED (W)	8	6	4
MAX CURRENT ABSORBED (A)	0.08	0.08	0.07
AIRFLOW (l/s)	25	18.1	6.9
dB(A) @ 3m	26.5	22	<20
IP RATING	IP45		
Ø DUCT (mm)	99		

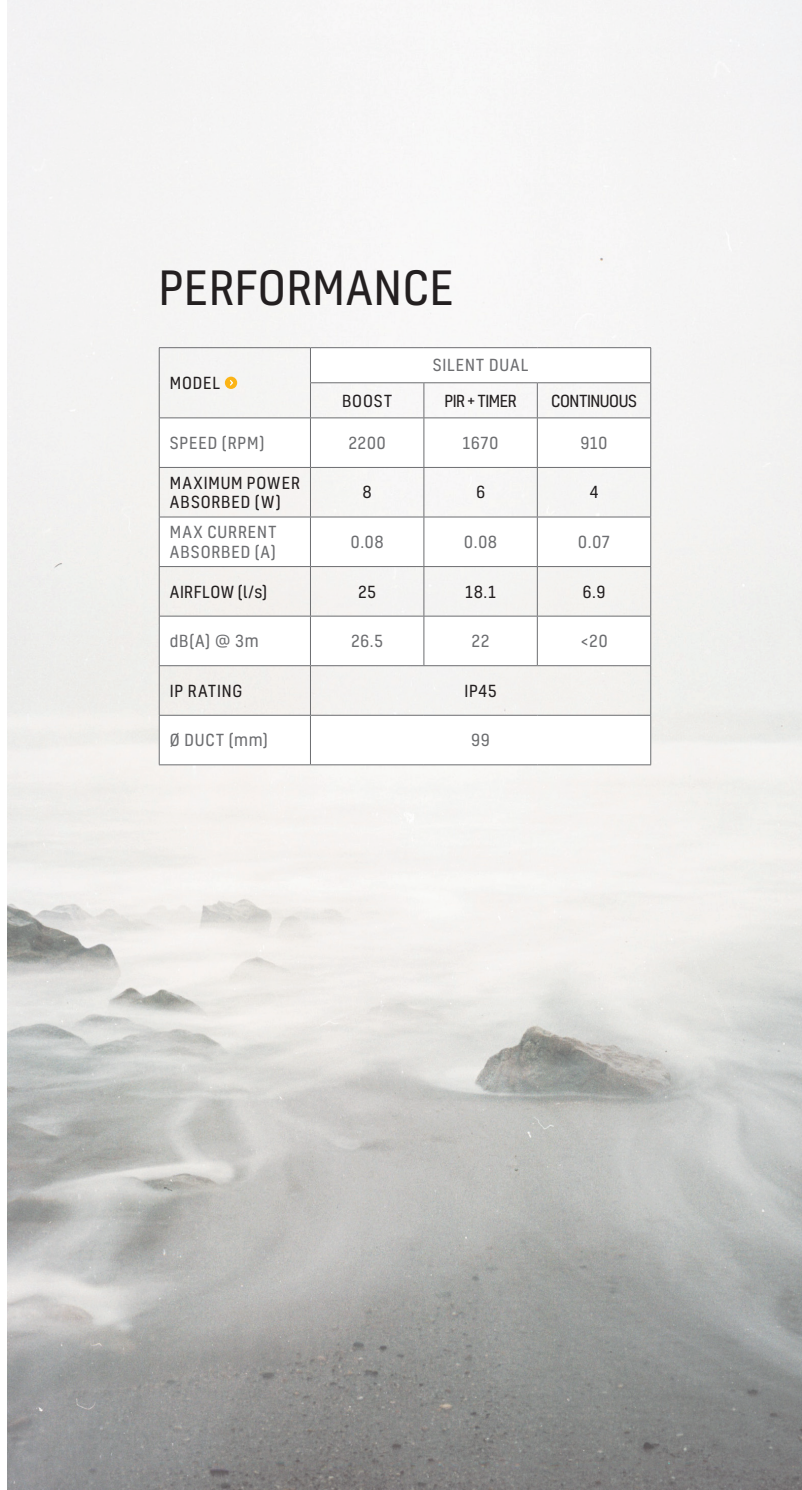

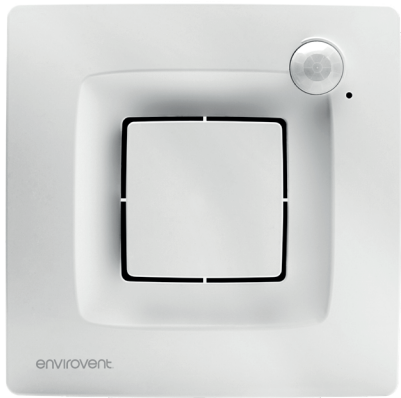

A

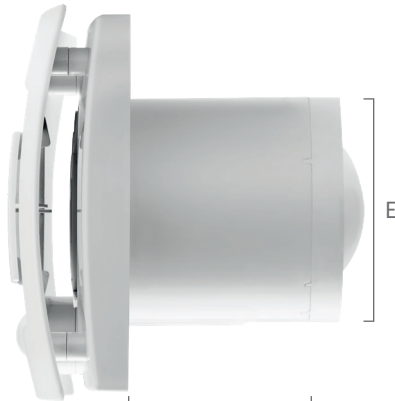

D

C

B

DIMENSIONS

FEATURES

With speed adjustable AC motor.
PIR Detector and Humidity sensor.
220-240V | 50Hz | -5/40°C
CL II | IP45

- A 167 mm
- B 157 mm
- C 103 mm
- D 77.5 mm
- E ø99 mm

PERFORMANCE CURVE

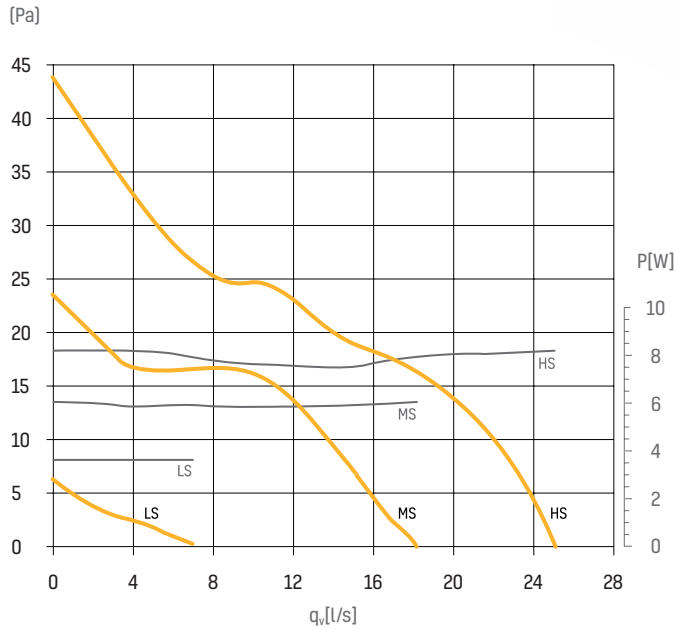

10 SILENT DUAL

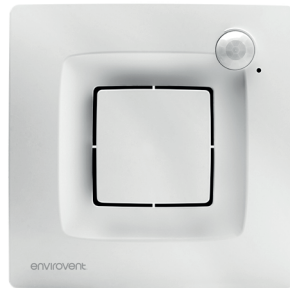

Leading Manufacturer & Supplier of Innovative Sustainable Ventilation Products

EnviroVent Ltd, EnviroVent House, Hornbeam Business Park, Harrogate, HG2 8PA
T 01423 810 810 / F 01423 301 022 / E info@envirovent.com / W www.envirovent.com

Due to our policy of continuous innovation and improvement, EnviroVent reserves the right to alter products specification and appearance without notice.

E&EO | MKT ENV391 - V3 - 13.01.2026

Copyright © EnviroVent Ltd 2020