

AFTER INSTALLATION THE END USER SHOULD
KEEP THIS GUIDE FOR FUTURE REFERENCE
DO NOT THROW AWAY

envirovent®

ATMOS®

ATMOS AIR & ATMOS INLINE
VENTILATION UNIT INSTALLATION GUIDE

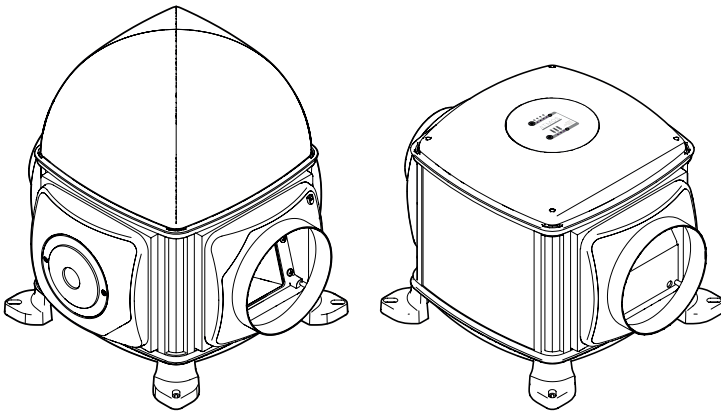

Safety

Read and understand these instructions before beginning installation. The unit should be installed by a competent person.

Location

Check there is space for the unit in your chosen location. The unit must not affect the operation of open-flue appliances. Consult local regulations or a qualified gas engineer. For air & inline units consider the external vent location in relation to external-flues from appliances e.g. boilers. You must ensure the vent is positioned a minimum of 1 metre horizontally or below a flue and when the supply vent is above a flue.

The open sides of the diffuser must face a minimum 1m unobstructed path away from any smoke detectors. If the diffuser cannot be repositioned, up to two sides can be closed using the plastic blanking plates. In this configuration the open sides must face a minimum 1.5m unobstructed path away from any smoke detectors. In properties with a floor above 4.5m fire diffusers must be fitted a minimum of 1m away from the smoke detectors instead of the included plastic diffusers.

Partition walls between buildings must be complete with any breaks filled.

In properties with a floor more than 4.5m above ground level the unit must be wired into a smoke alarm (see page 17 for wiring information).

The appliance is considered suitable for use in countries with a warm damp equable climate, but may also be used in other countries.

Wiring Regulations

All wiring must comply with Building Regulations and the current IET Wiring Regulations (BS7671 in the UK) or equivalent standards for other countries. The final installation should be examined and tested by a qualified electrician.

This product is not suitable for use with a Type AC RCD 

Electrical Connection

The unit must be earthed and a suitable isolator with a minimum contact separation of 3.0mm must be used to provide insulation for the unit. The unit must be able to be disconnected from the mains supply after installation. When wiring the unit, the included unswitched fuse spur should be incorporated in the fixed wiring.

The power supply cable running into the unit must remain the supplied flexible cable (not a solid core lighting cable). If the power supply cable becomes damaged, it must be replaced by EnviroVent, an authorised service agent for your region/country, or a similarly qualified person in order to avoid a hazard. Do not remove or tamper with any electronic components inside the product.

Users

The unit is not intended for use by persons (including children) with reduced physical, sensory or mental capabilities or lack of experience and knowledge, unless they have been given supervision and usage instruction by a person responsible for their safety. Children should be supervised to ensure they do not play with the unit. Cleaning and user maintenance must not be performed by children.

Diagrams

ATMOS AIR

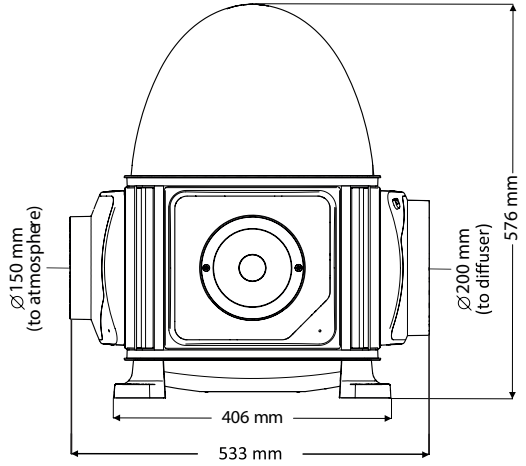
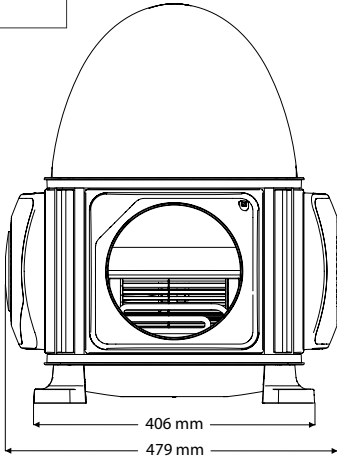

ATMOS AIR DUAL

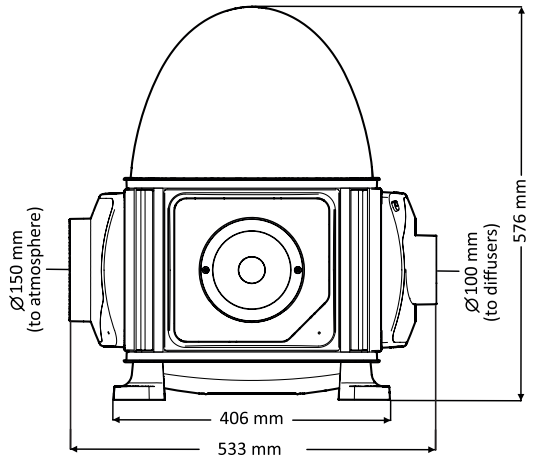
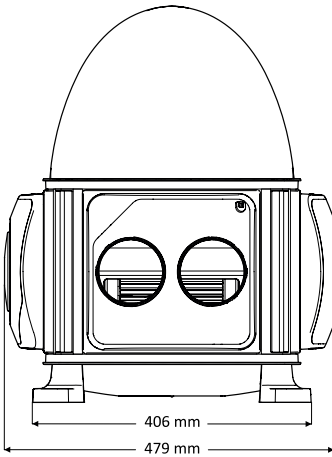

ATMOS INLINE

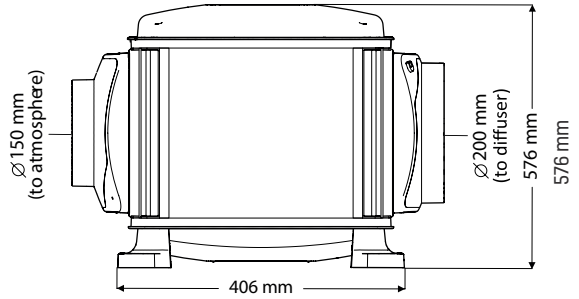
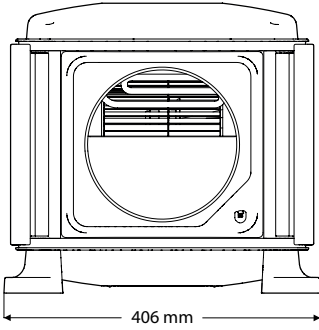

ATMOS INLINE DUAL

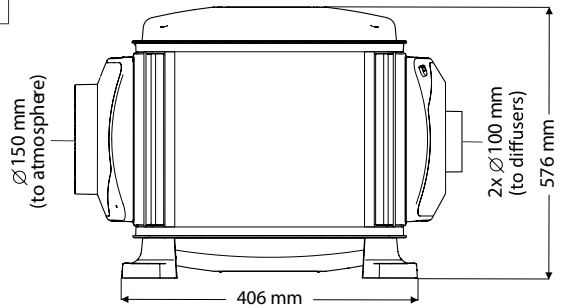
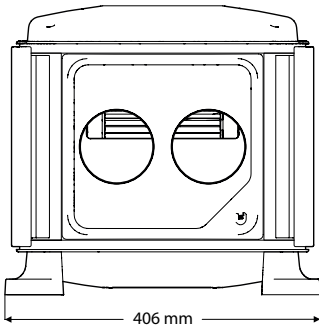

AFTER INSTALLATION THE END USER SHOULD
KEEP THIS GUIDE FOR FUTURE REFERENCE

DO NOT
THROW AWAY

envirovent®

INLINE DUCT CONFIGURATIONS

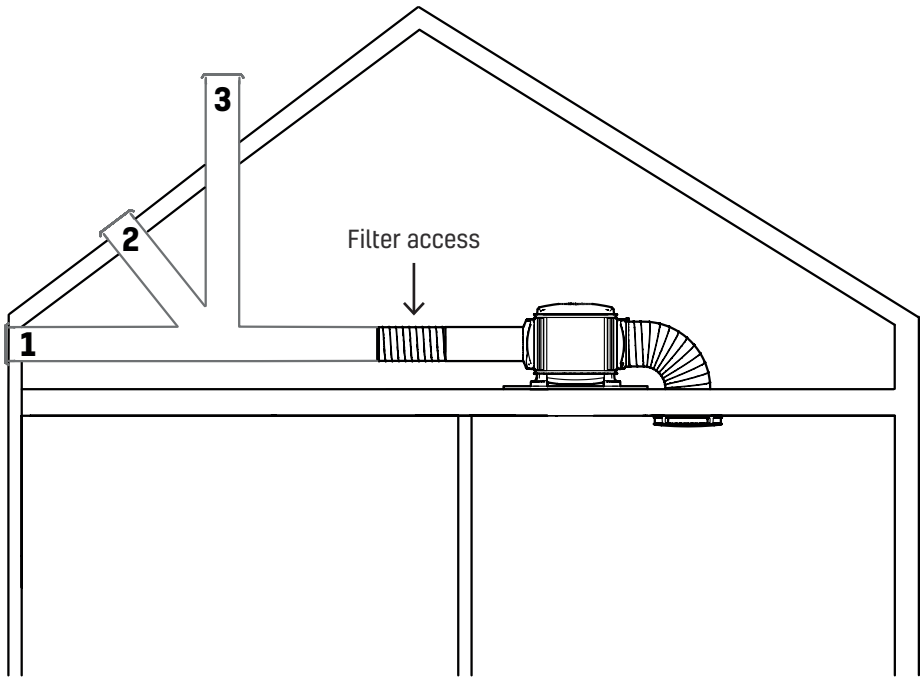

Use one of three options to connect the inline duct to the outside of the property [extra parts not supplied]:

1. Straight duct to a wall mounted vent or grille.
2. Angled duct to a roof tile vent.
3. 90 degree bend duct to a straight roof vent.

KEYPAD - App / Remote Control / Inline units

- 1 - Set Airflow
- 2 - Variable airflow
- 3 - Hours run
- 4 - Wi-Fi (only on app units)
- 5 - Filter
- 6 - Auto comfort heater enable/disable
- 7 - Temperature
- 8 - Top button
- 9 - Numeric Display
- 10 - Bottom button

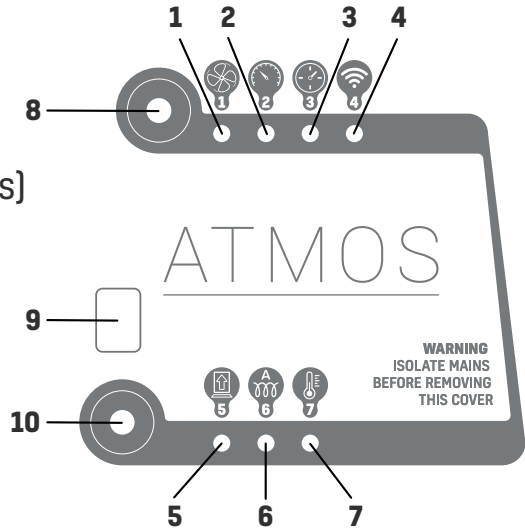

KEYPAD - Standard units

- 1 - Airflow 1
- 2 - Airflow 2
- 3 - Airflow 3
- 4 - Airflow 4
- 5 - Temperature <19°C
- 6 - Temperature >19°C
- 7 - Temperature >25°C
- 8 - Top button
- 9 - Numeric Display
- 10 - Bottom button

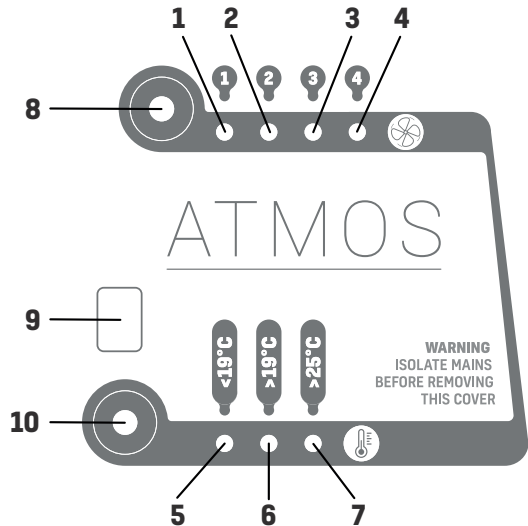

WIRING

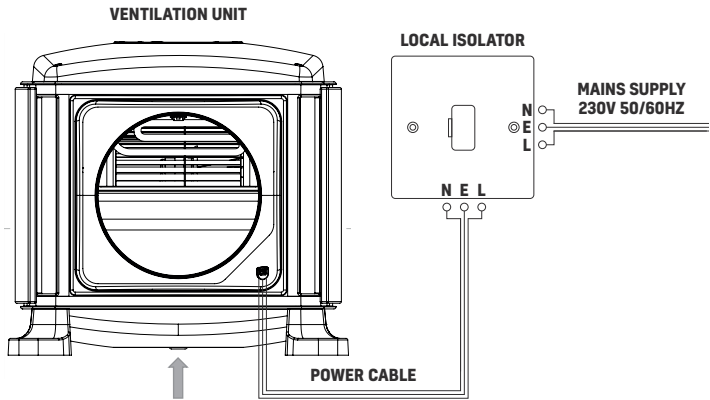

TO CONNECT OPTIONAL 0-10V (RF AND APP UNITS ONLY) OR HEATER ENABLE CABLE SEE STEP 1 TO 3

The local isolator must be connected to the mains as part of the fixed wiring. Connect the N, L and E cores of the power cable to the matching terminals on the local isolator.

1

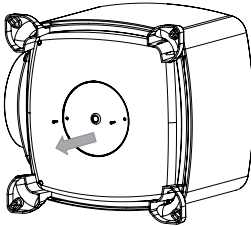

Remove base cap (two screws)

2

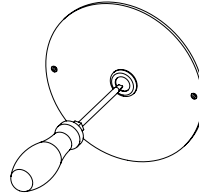

Make small hole in grommet and thread 2 core cable through

3a

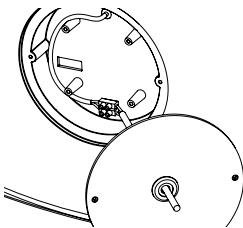

0-10V
Red=+V
Blue=0V

Wire in 2 core cable

3b

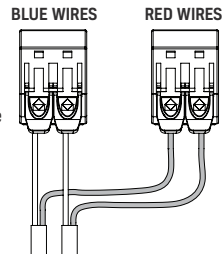

Heater enable
Volt free
connection

Wire in 2 core cable

ATMOS AIR / INLINE **box contents**

- 1x ATMOS AIR unit / inline unit
- 1x Loft Filter (not on inline unit)
- 2x Flexible filter rods (not on inline unit)
- 1x 150mm Inline filter
- 1x 200mm diffuser (+ 2x blanking plates)
- 1x Instruction guide
- 1x Diffuser mounting template
- 1x Flexible duct (1m x 200mm dia.)
- 1x Unswitched fuse spur
- 1x Remote control (Remote Control units)
- 8x Foam pads
- 4x Washers
- 4x Screws 10g x 3"
- 4x Screws 10g x 1.5"
- 4x Screws 8g x 1.5"
- 4x Screws 8g x 1"
- 4x Plasterboard plugs
- 2x 200mm duct fixings
- 1x 150mm duct fixing

ATMOS AIR DUAL / INLINE **DUAL box contents**

- 1x ATMOS AIR DUAL unit / inline unit]
- 1x Loft Filter (not on inline unit)
- 2x Flexible filter rods (not on inline unit)
- 1x 150mm Inline filter
- 2x 100mm diffusers
- 1x Instruction guide
- 2x Flexible ducts (3m x 100mm dia.)
- 1x Unswitched fuse spur
- 1x Remote control (Remote Control units)
- 8x Foam pads
- 4x Washers
- 4x Screws 10g x 3"
- 4x Screws 10g x 1.5"
- 4x Screws 8g x 1.5"
- 4x Screws 8g x 1"
- 4x Plasterboard plugs
- 4x 100mm duct fixings
- 1x 150mm duct fixing

Pre - Installation Checklist

- Does the unit fit through the loft hatch?
- Check there are no obstructions in the hallway or landing where the diffuser is to be fitted and in the loft space above.
- Ensure the loft has adequate cross-flow ventilation to provide a supply of fresh air to the unit.
- Check that all partition walls are intact. Seek building advice if any are missing or broken.
- Check for flued appliances drawing air from the loft, the user should be made aware of any of these.
- Check that any flue passing through the loft is undamaged. Seek building advice if any are damaged or broken.
- Repair any ceiling gaps which allow air leakage into the loft.
- Ensure any loft water storage tanks are covered and sealed.

About ATMOS units

The ATMOS AIR and ATMOS Inline are Positive Input Ventilation (PIV) units which create fresh and healthy living environments by supplying filtered air into a property at a continuous rate through ceiling mounted diffusers. The diffusers are normally installed in a hallway or landing area.

The units have been developed to improve indoor air quality and reduce condensation and mould problems.

In conditions between 19°C - 25°C the units will increase air flow rate by 10%. Above 25°C the ATMOS AIR units automatically switch to bringing air directly from outside to avoid bringing hot air into the property from the loft space.

The ATMOS AIR unit uses a single 200mm diffuser to provide air into a hallway or landing area.

The ATMOS AIR DUAL unit uses two 100mm diffusers to provide airflow to separate locations within the building. It is normally required for applications where:

- a) The hallway is small.
- b) Limited heating is available.
- c) The loft hatch fills the hallway ceiling.
- d) Airflow is required in a remote area such as a bedroom.

Option 1

If a higher airflow is required in the hallway, position that diffuser a shorter distance from the unit.

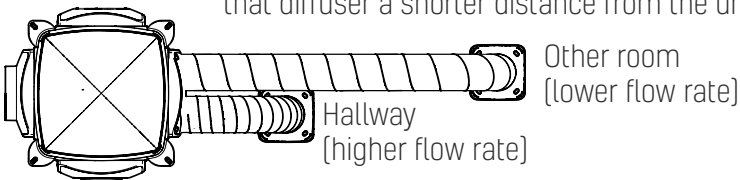

Option 2

If a similar airflow is required in the hallway, position both diffusers at similar distances from the unit.

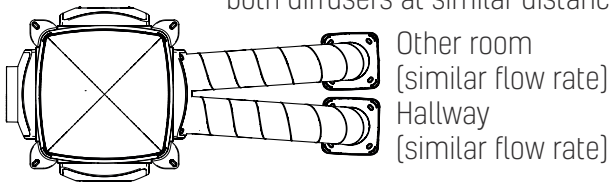

Installation

1. Place a dust sheet below the required ceiling diffuser position and check the ceiling below and loft space above are unobstructed.
2. a) For ATMOS AIR mark a 222mm diffuser hole using the template.
2. b) For ATMOS AIR DUAL mark two 105mm diffuser holes [see page 10 for positioning information].
3. Wearing a dust mask and eye protection, cut out the hole/s.

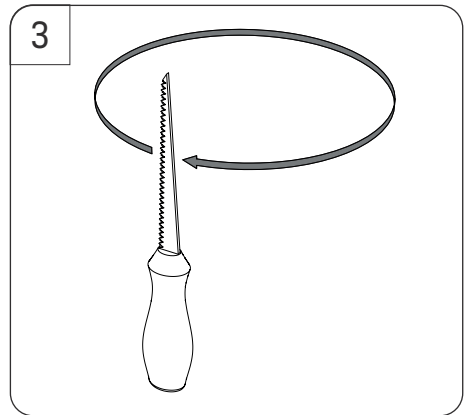
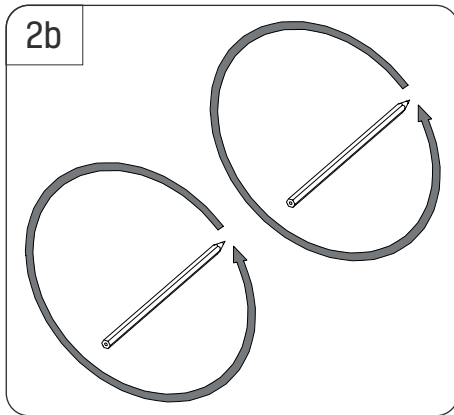
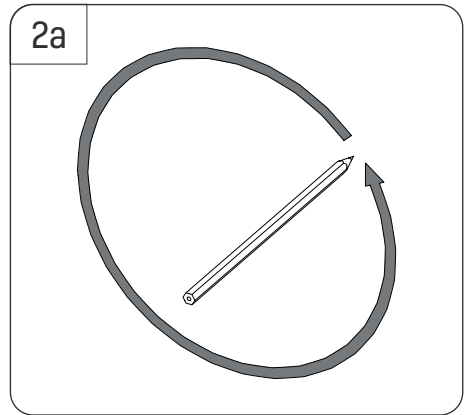
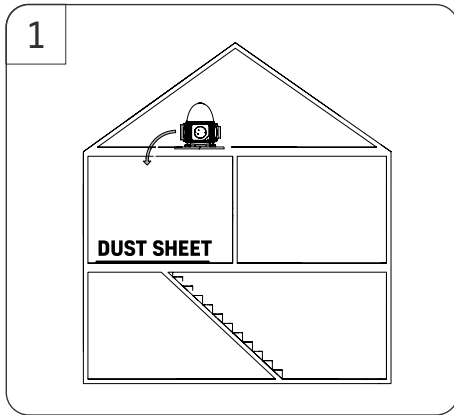

4. a) Screw the feet of the unit onto two 25mm x 50mm wood battens using the **four 10g x 1.5" screws**. (Battens not supplied).
4. b) Position the unit with anti-vibration pads and washers onto the loft ceiling joists as in the diagram.
4. c) Screw the battens to the ceiling joists using the **four 10g x 3" screws**.
4. d) If the loft insulation sits above the joists and impedes the unit, create a raised wooden platform to mount onto.

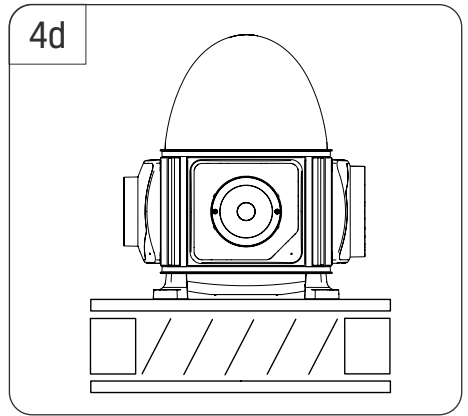
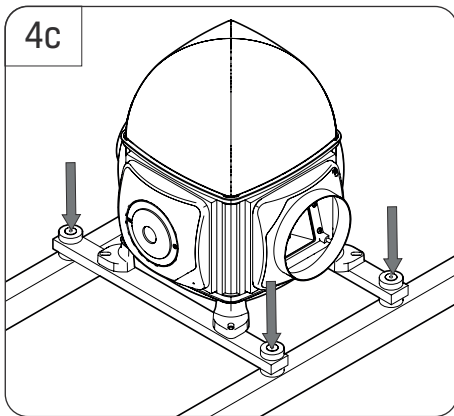
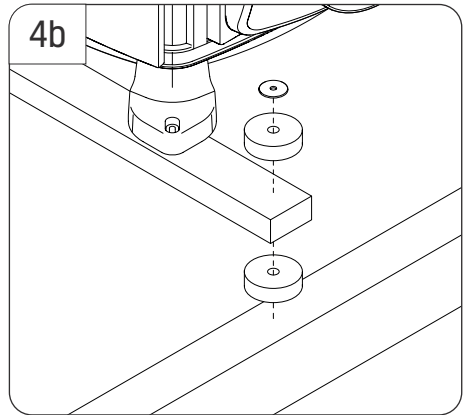
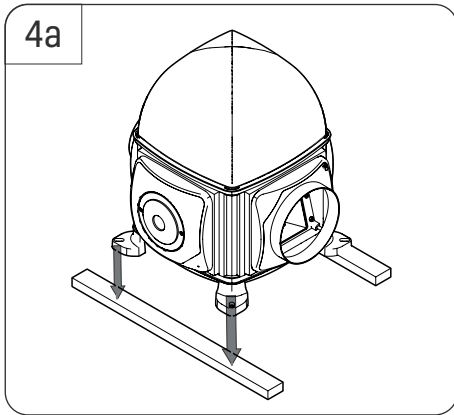

5. Insert the diffuser spigot into the ceiling hole so that the diffuser outlets face towards the walls then mark the four fixing holes.
6. Attach the duct to the spigot of the diffuser and seal the connection using the fixings supplied.
7. Insert the diffuser spigot into the hole then fix it in place.
Use the four plasterboard plugs and four 8g x 1.5".
Then clip the diffuser cover into the diffuser spigot.
8. Attach the flexible duct to the spigot on the unit and ensure it is pulled taut. Seal the connection tightly using the fixings supplied. Cut the duct to length if required.

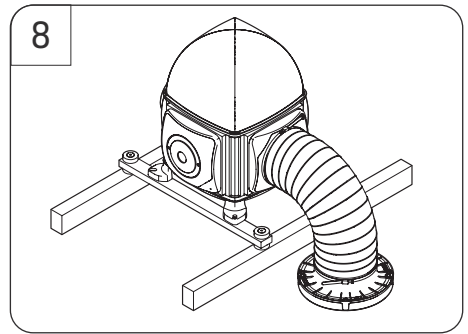
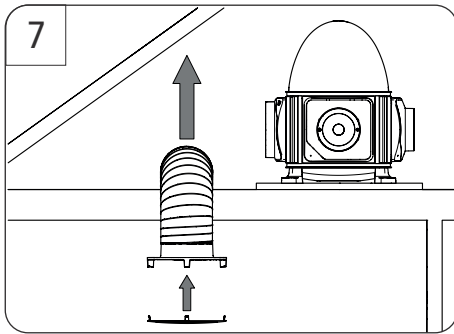
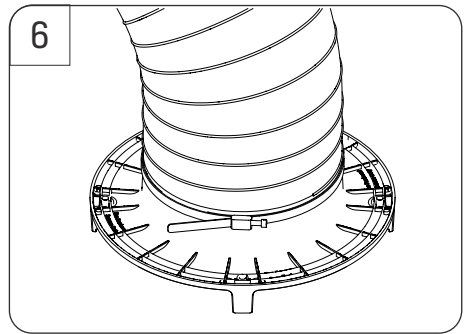
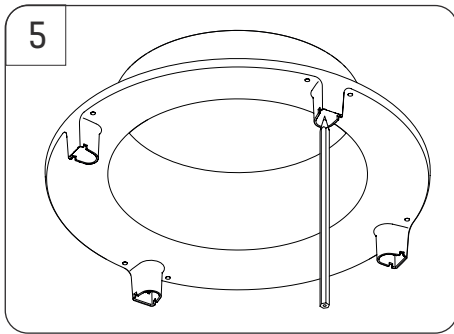

9a. INLINE FILTER (all units)

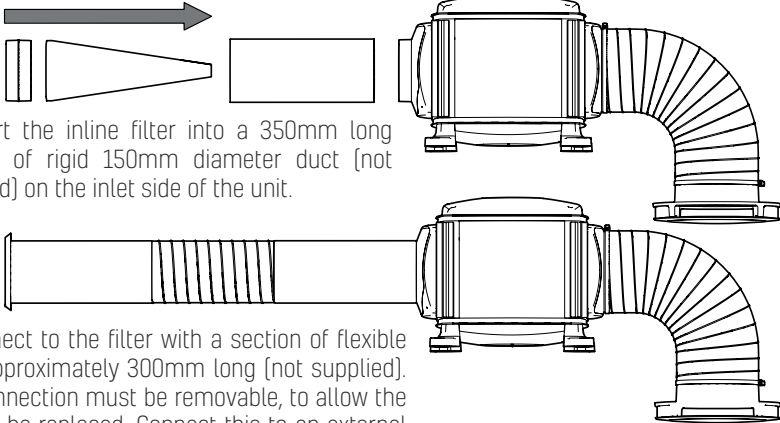

1. Insert the inline filter into a 350mm long section of rigid 150mm diameter duct (not supplied) on the inlet side of the unit.

2. Connect to the filter with a section of flexible duct approximately 300mm long (not supplied). The connection must be removable, to allow the filter to be replaced. Connect this to an external vent (see page 5 for examples).

9b. LOFT FILTER (AIR & AIR DUAL only)

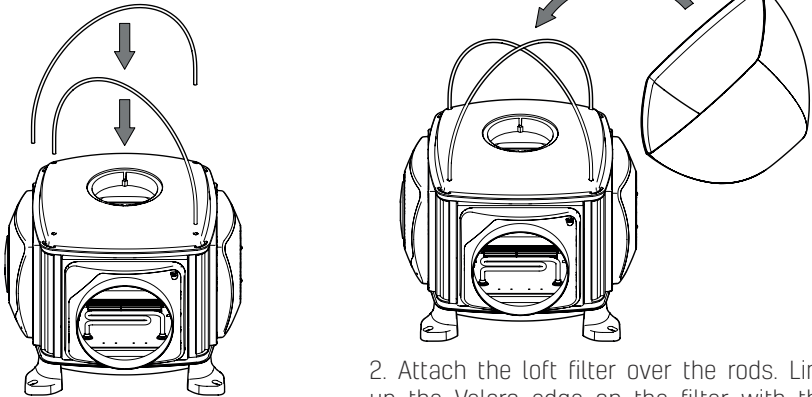

1. Insert the two flexible filter rods into the holes in the lid so they cross in the middle.

2. Attach the loft filter over the rods. Line up the Velcro edge on the filter with the matching Velcro edge on the lid and ensure it is attached all the way round.

10. With the mains supply isolated, wire the power cable into the unswitched fuse spur then wire the unswitched fuse spur into the mains supply [see wiring diagram on page 7].

Use two of the 8g x 1" screws to attach the spur to a loft joist.

11. a) App and Remote Control units can be connected to an AirSens intelligent IAQ sensor [not included]. See AirSens instructions for wiring.

11. b) Standard units can be wired to a heater enable switch [not included]. Wire into the connection located under the unit [see Page 7, cable not included] and fit it in an accessible area. **Do NOT wire into mains or any other power source. Use two of the 8g x 1" screws to attach the switch to the wall.**

12. Reconnect the mains supply at the local isolator. After a few seconds air will begin to flow from the diffuser [see page 19/20 for air flow rate settings].

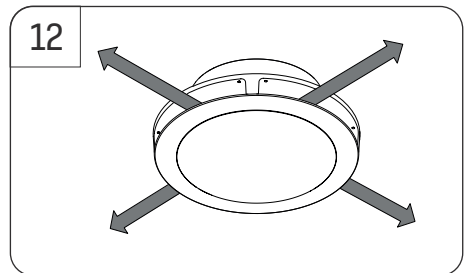
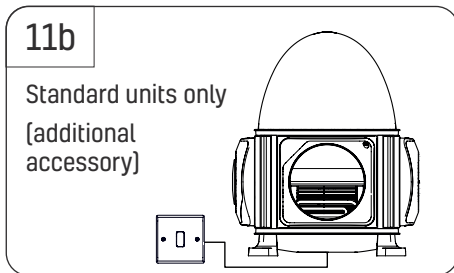
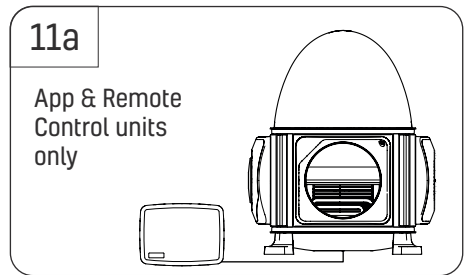
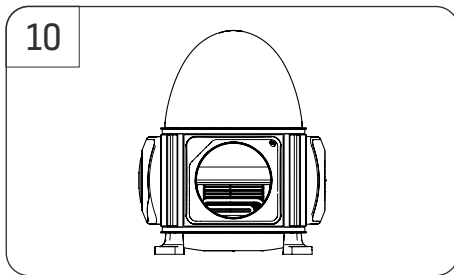

Fire Safety

Fire Kits

For installations with a floor more than 4.5m above ground, a compatible fire kit must be fitted. The kits listed below contain all the extra parts and instructions required:

Order Code	Description
KIT-PIV-SMOKE-200	200mm fire-rated diffuser for PIV units only
KIT-MIV-SMOKE-125	2x 125mm fire-rated diffusers for MIV units only

Smoke Alarms

For installations with a floor more than 4.5m above ground, the unit must be wired into a smoke alarm in order to switch the unit off upon the detection of smoke.

The unit can be wired into an existing smoke alarm (check compatibility with the smoke alarm manufacturer). All wiring should be completed by a competent person.

To test the installation, press the TEST button on top of the smoke alarm and keep it pressed until the PIV unit switches off (LEDs on the board go out).

SMOKE ALARM WIRING

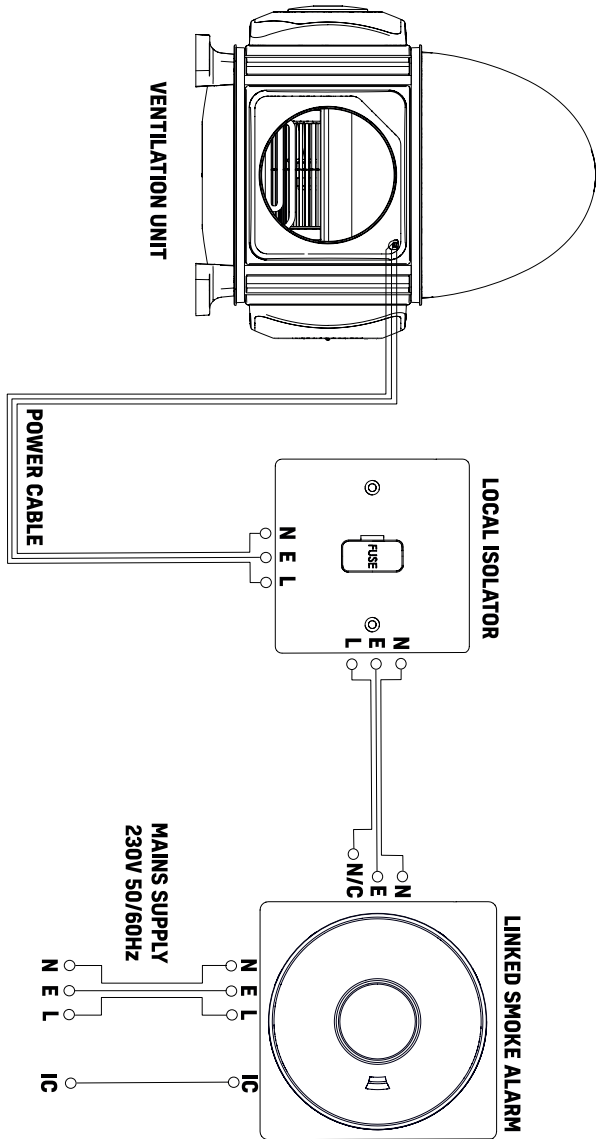

SETTINGS - Standard Units

Top button

- Press to show the current air flow rate setting.
- The corresponding LED will illuminate on the keypad.
- Further presses scroll through the air flow rate settings 1, 2, 3 and 4 on a loop.
- Adjust this according to the size, type and occupancy of the property.

Bottom button

- Press to show the total running time.
 - The numeric display will illuminate to show the total amount of time the unit has been running. e.g. '1234' (hours)
-

Wi-Fi App myenvirovent

App enabled units can be controlled using the myenvirovent app on Apple and Android devices. The SSID and password information for the unit is printed on the back page of this installation guide and also on a label attached to the unit.

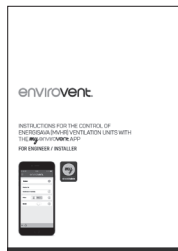

A separate instruction guide for the myenvirovent app is included in the box. Once the unit has been installed, refer to this guide for connection and further settings.

SETTINGS – App & Remote Control units







Top button

- Press to activate the numeric display.
- Further presses scroll through the modes on a loop.
- The corresponding LED will illuminate on the keypad.

Bottom button

- Press for 2 seconds to modify the settings for the highlighted mode.
 - The corresponding LED will flash on the keypad.
 - The current setting will be shown on the numeric display.
 - Quick press to alter the setting. The available options will scroll on a loop.
 - Press for 2 seconds to save changes to the selected mode.
 - After 30 seconds of inactivity the current settings will be saved and the numeric display will turn off.
-

Modes [corresponding display information is shown in bold]

- 1. Set air flow rate:**  Factory set air flow rates **'1' / '2' / '3' / '4'**.
Select according to the size, type and occupancy of the property.
- 2. Variable air flow rate:**  Variable air flow rate for fine tuning **'32'...'100'** [increments of 2% from 32% to 100% of the maximum air flow rate]. The mode will engage after the value has been selected.
- 3. Hours run:**  Total time the unit has been running [hours].
- 4. Wi-Fi:**  Access point **'F'** / Network connected **'C'**
Press bottom button for 10 seconds to reset access point.
- 5. Filter usage:** 
 - Total usage time remaining [days].
 - Filter period setting **'12' / '24' / '36' / '48' / '60'** [months]
- 6. Additional modes:** 
 - Comfort heater: **'H0' / 'H-'** [on / off]
 - Comfort heater temperature: **'h5'...'h15'...** [increments of 1°C from 5 to 15]
 - Boost time: **'b20 / b40 / b60 / b720'** [20 mins / 40 mins / 60 mins / 720 mins]
 - Summer temperature: **'t18'...'t28'** [increments of 1°C from 18 to 28]
 - Summer mode: **'d0' / 'd-'** [on / off]
 - Kick up: **'U0' / 'U-'** [on / off]
- 7. Comfort Heater on/off:**  LED will illuminate when the heater is powered.

Wireless Remote Control

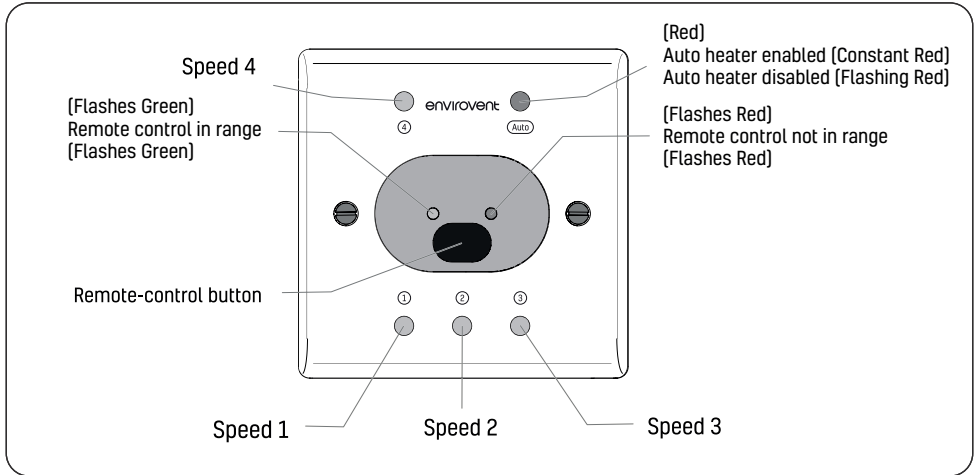

•To indicate the current status of the unit:

-Press the remote-control button once and the LEDs will light up according to the current status of the unit.

•To modify the air flow rate:

- Press the remote-control button once
- Further presses will then cycle the unit through each of the air flow rate settings - 1, 2, 3, 4
- Further presses will cycle back through the same settings

•To enable/disable the automatic comfort heater function:

- Press the remote-control button once.
- Press again for 5 seconds to disable comfort heater function.
- AUTO LED will flash red for 5 seconds.
- Press again for 5 seconds to enable comfort heater function.
- AUTO LED will light constant red for 5 seconds.

Pairing an additional remote-control:

1. Turn the unit off at the isolation point.
2. Restore power; for 20 seconds from restart the unit will be in pairing mode.
3. Press the remote-control button once within the 20 seconds and the control will pair to the unit.
4. Successful pairing is indicated by a green light on the remote.

Remote-control batteries

When the battery needs to be replaced, unscrew the switch front cover. The battery is located on the back of the cover. Battery type 3V Lithium CR2032. The switch will remain paired with the unit after battery replacement. Ensure the new battery is inserted with correct polarity, and the removed battery is safely disposed of.

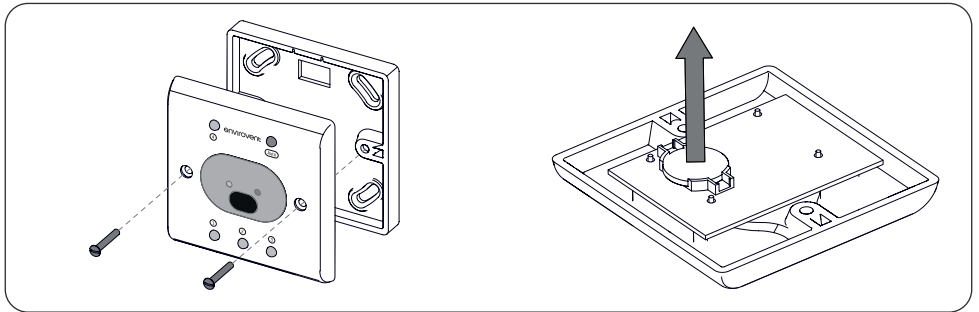

Wired comfort heater enable/disable

A switch to enable/disable the heater function can be connected up to 3 metres away from the unit. This must be a volt free contact. Do not wire the cable or switch into the Mains. When the switch is pressed on, the comfort heater function is enabled and the system will maintain the incoming air temperature at 10 °C. When the switch is pressed off, the automatic comfort heater function is disabled.

Performance Figures - ATMOS AIR

House size setting	Max air flow rate [l/s] ^a	Power usage [Watts] ^b
1.	22	3
2.	29	4
3.	35	5
4.	43	8

Performance Figures - ATMOS AIR DUAL

House size setting	Max air flow rate [l/s] ^a	Power usage [Watts] ^b
1.	19	3
2.	24	4
3.	30	7
4.	36	11

Performance Figures - ATMOS INLINE

House size setting	Max air flow rate [l/s] ^a	Power usage [Watts] ^b
1.	28	2.7
2.	38	3.8
3.	46	5.4
4.	56	8.3

Performance Figures - ATMOS INLINE DUAL

House size setting	Max air flow rate [l/s] ^a	Power usage [Watts] ^b
1.	22	3
2.	29	4
3.	35	5
4.	43	8

^a Diffuser installed without blanking plates fitted.

^b Power usage shown with comfort heater function disabled.

^c Figures calculated at incoming air temperature below 19 degrees C.

Running costs

Please scan our QR code to see the annual running costs of this product.



Or visit: envirovent.com/annual-running-costs

Spares/Accessories

Item Description	Order Code
Replacement coarse particle filter (ISO coarse 65%)	FILTERMIVAS-COARSE
Replacement Inline filter	1ACFILTASSY150
Replacement 200mm diffuser	1DIFPIV
Replacement 100mm diffusers	1DIFEVLSML1
Fixing kit - ATMOS	FIXINGKITATL
AirSens IAQ sensor [CO ² model]	AIR-CO2
AirSens IAQ sensor [RH model]	AIR-RH
AirSens IAQ sensor [VOC model]	AIR-VOC
Duct Clamp 100mm	DUCTCLAMP100MM
Duct Clamp 165mm	DUCTCLAMP165MM
Duct Clamp 200mm	DUCTCLAMP200MM
Heater switch*	HEATER ENABLE SWITCH
Smoke alarm**	1ACSMOKEALARM-KIT

*Additional two core cable required. **Additional four core cable required.

Maintenance

EnviroVent recommend that filters are checked regularly and replaced as required. The unit should be isolated from the mains when replacing or cleaning filters.

Areas with high particulate matter for example industrial areas, or higher-grade filters will become clogged quicker and will need replacing more frequently. Spare and replacement filters must be genuine EnviroVent parts.

Failure to maintain the unit as recommended may breach the terms of the warranty. See full warranty terms and conditions for further information.

Servicing

EnviroVent recommend that all units are serviced annually to maintain optimal performance, if you would like a service or more information, please contact us on **01423 810 810**.

Warranty

We appreciate you choosing this quality EnviroVent product, which is designed and manufactured to the highest specification in Harrogate, North Yorkshire. We are confident that you will be delighted with the performance of the system and the resulting improvement in air quality in your home after the installation of the unit.

The EnviroVent ATMOS AirSource and Inline ventilation units are covered by a supply and fit 10-year warranty. Please note that conditions and exclusions apply to the warranty which can be found at www.envirovent.com/warranty

Your unit serial number

What should I do if I have a problem?

If you encounter any problems with your unit, please feel free to call us on **01423 810 810**.

AFTER COMPLETING INSTALLATION, PASS THIS GUIDE
ONTO THE END USER FOR FUTURE REFERENCE
DO NOT THROW AWAY

envirovent[®]

Leading Manufacturer & Supplier of
Innovative & Sustainable Ventilation Systems

EnviroVent Ltd
Harrogate West Business Park
Unit 1 Bardner Bank
Killinghall
Harrogate
HG3 2SP

T / 01423 810 810
E / info@envirovent.com
W / envirovent.com

Boxed unit weight: 9.2kg Unboxed unit weight: 7.1 kg

E&OE | MKT ENV358 - V14 - 02.12.25

Due to our policy of continuous innovation and improvement EnviroVent reserves the right to alter products specification and appearance without notice.

We want to hear from you

Your feedback is important to us as we strive to improve our products, services, and overall customer experience. Please email us to help us serve you better: feedback@envirovent.com