

TECHNICAL DATA SHEET EBB Design | Centrifugal WC & Bathroom Fan



KEY FEATURES

- ✓ Powerful forward curved centrifugal impellers
- ✓ Automatic backdraught shutter as standard
- ✓ IP44 rated
- ✓ 2 year warranty
- ✓ High performance
- ✓ Significant energy savings
- ✓ Quiet operation
- ✓ Complies with local building regulations

PRODUCT

The EBB Design extractor fan is suitable for WC, bathroom & kitchen applications where higher system resistance pressures are encountered.

The EBBDES-175 has 2 different models: standard [EBBDES-175S], timer [EBBDES-175T].

The fan incorporate a forward curved centrifugal impeller with single phase motor 230V-50Hz and Class II insulation. Maximum operating temperature 40°C.

APPLICATIONS

The EBB Design can be wall or ceiling mounted.

INSTALLATION

Full installation guide is enclosed with all products; or sent separately in advance - if required.

MOTOR

Is a single phase motor 230V 50Hz.

FAN

The impeller is a powerful forward curved centrifugal fan to deliver high performance against high static pressure resistance.

WARRANTY

The EBB Design range is covered by a parts only 2-year warranty. Please note that conditions and exclusions apply to the warranty which can be found at www.envirovent.com/warranty

COMPLIANCE

CE Marked

PERFORMANCE

MODEL ^o	EBB 175 DESIGN	
	LS	HS
SPEED (RPM)	930	1250
WATTS (W)	17	26
VOLTAGE (V) 50Hz	230	230
AIRFLOW l/s (m ³ /h)	22 (80)	43 (155)
dB(A) @ 1.5m	33	41
WEIGHT (Kg)	2.2	
IP RATING	IP44	
Ø DUCT (mm)	98	

TECHNICAL DATA SHEET EBB Design | Centrifugal WC & Bathroom Fan

DIMENSIONS (MM)

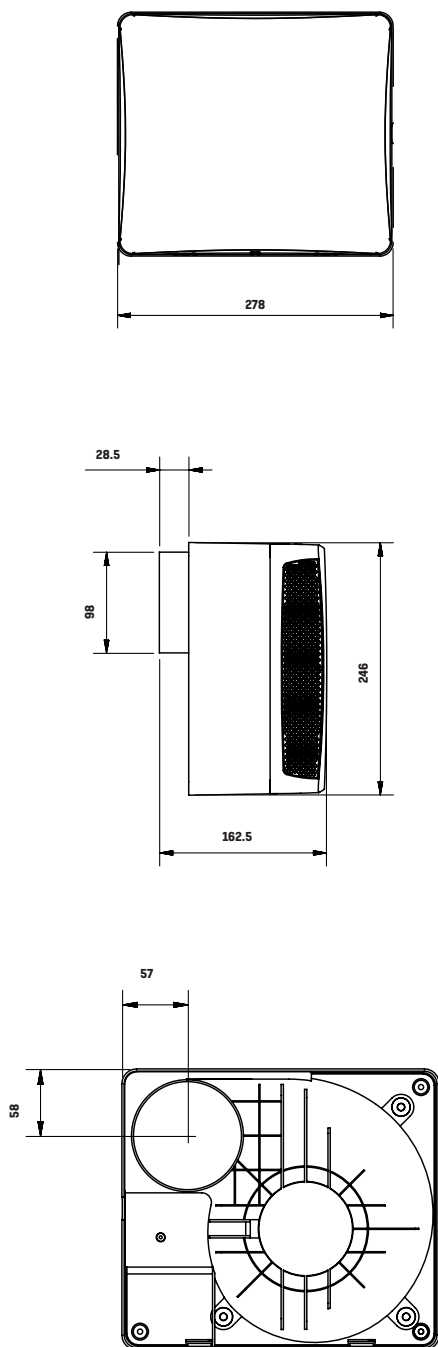

PERFORMANCE CURVE

EBB 175 Design

