

envirovent®

ENERGISAVA® 200

High Efficiency Whole House Heat Recovery Unit



ENERGISAVA® 200

High Efficiency Whole House Heat Recovery Unit



About

Incorporating a powerful backward curved EC motor, the energisava® 200 delivers exceptional performance within a compact unit. Ideal for medium sized houses with kitchen plus 4 additional wet rooms the stylish little energisava® 200 achieves a maximum airflow of 241m³/h (67l/s) and a high maximum system pressure in excess of 500Pa.

Features & Benefits

- Delivering up to 89% thermal efficiency
- Automatic and integral mechanical summer bypass as standard
- Three speed wireless remote control as standard
- Intellitrac® humidity control technology as standard
- Frost protection as standard
- Can be wall or ceiling mounted
- Easy access to removable filters
- Easy commissioning via a push button commissioning pad or via the MyEnvirovent App
- App enabled version available
- Right Hand and Left Hand versions available
- Stylish design
- High performance
- SAP PCDB listed
- 2 year warranty
- ErP A rated



Stylish Design & Optimum User Functionality

Designed with stylish aesthetics and easy access to the removable filters for maintenance, the energisava® 200 continuously operates at a low level to ensure the home is correctly ventilated, providing all year round good indoor air quality.

Highly practical, the energisava® 200 comes as standard with a three speed remote control to adjust the unit's airflow between trickle, boost and third speed rates. It also indicates when the summer by-pass is activated and includes a filter change and fault indicator.



The automatic, integral mechanical summer by-pass ensures that cooler air enters the property on warmer days, creating an ideal indoor climate.

Easy Maintenance

The energisava® 200 comes complete with a 2 year warranty. To ensure the optimum performance of the system, it is important to maintain the unit. This can be done by simply removing a section of the front cover and accessing the exchangeable filters **(order code: FILTER-ESG3)**.

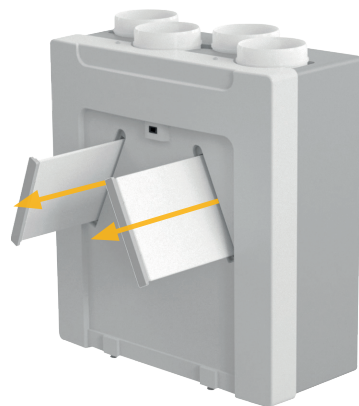

Flexible Installation & Ease of Commissioning

The energisava® 200 has been designed for ease of installation in mind. With vertical or horizontal mounting options, the unit can be installed on the ceiling, or wall.

The units come complete with easyfit brackets for rapid installation without the requirement to access the unit.

For ease of commissioning the push button pad on the unit enables the installer to correctly set the required airflow rate quickly and effectively.



Wall



Ceiling

Intellitrac® Technology

The energisava® 200 incorporates Intellitrac® Technology, the unique humidity tracking controls. The unit runs continuously on trickle, providing all year round healthy indoor air quality.

No user intervention is required as the Intellitrac® Technology constantly monitors the average humidity level in the home. This allows the system to sense any rise in humidity and increases both air flows in direct correlation to quietly and efficiently control condensation. Once the humidity level falls, the extract rate tracks back down again, saving energy.



myenvirovent.

Revolutionise the way you control your ventilation system.

The energiSava® 200 is now available with the new myenvirovent App. It is designed to offer total control of the unit from anywhere in the home at the touch of a button. Not only does it provide smart userability for the resident, it also enables rapid commissioning for the installer:

- Greater control of ventilation requirements in the home
- Flexibility to amend ventilation settings
- Manage ventilation rates from anywhere in the home, from trickle, to boost, to third speed.
- Multiple user access
- Filter change notifications
- Instant access to current unit status
- Secure connection through a router
- Reduce installation time by commissioning from a mobile device

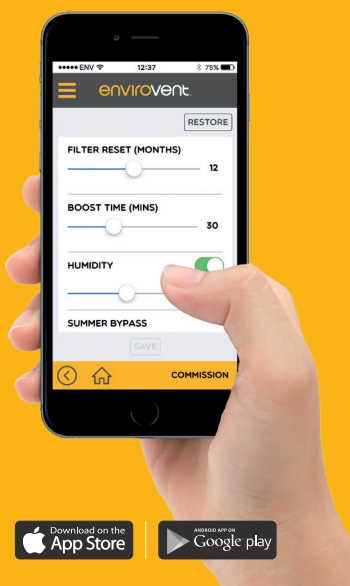

Summer By-Pass

Benefiting from a temperature controlled integral summer by-pass as standard, the air is routed around the heat exchange cell to ensure that cooler outdoor air replaces the indoor air that has been heated during the day. The summer by-pass ensures that the full benefit of perception cooling is achieved.

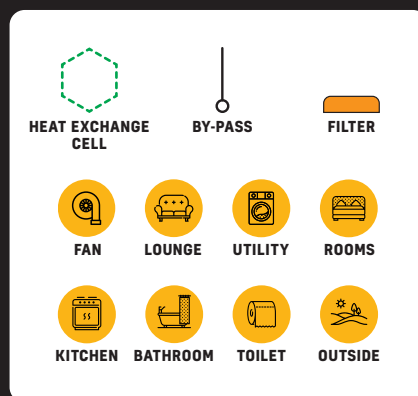
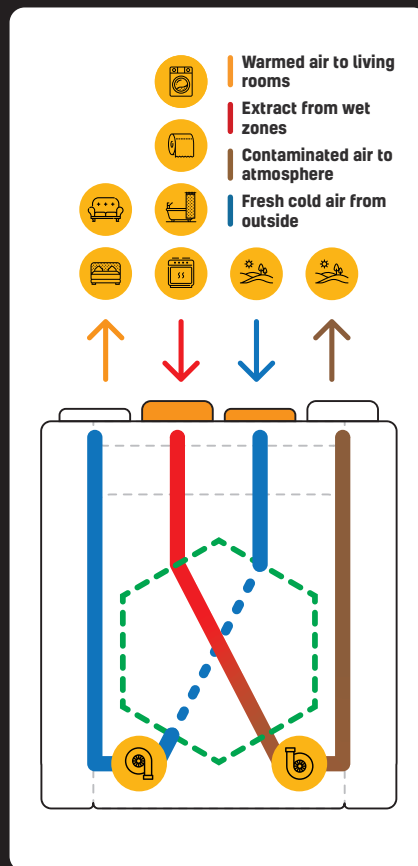

Technical Characteristics

| | |
|------------------------------|------------------------|
| Maximum Flow Rate l/s (m3/h) | 67 (241) |
| Heat Exchanger | Counter Flow (Plastic) |
| Efficiency (%) | 89 |
| Fans | EC |
| Specific fan power (W/l/s) | 0.79 |
| Electrical Supply | 230V / 1PH / 50Hz |
| Max Power Consumption (W) | 130 |
| Supply Filter | ISO Coarse 45% |
| Extract Filter | ISO Coarse 45% |
| Spigot (mm) | 125 |
| Dimensions (mm) | 571 x 646 x 335 |
| Weight (Kg) | 14 |

SAP Appendix Q Performance

| Exhaust Terminal Configuration - Kitchen + Additional Wet Rooms | Specific Fan Power (W/l/s) | Heat Recovery Efficiency (%) |
|---|----------------------------|------------------------------|
| + 1 additional wet room | 0.79 | 89 |
| + 2 additional wet rooms | 0.91 | 87 |
| + 3 additional wet rooms | 1.14 | 85 |
| + 4 additional wet rooms | 1.43 | 84 |

For sound data figures, please contact EnviroVent on **01423 810 810**

Technical Specification

Product

The energiSava® 200 shall be a compact and lightweight whole house heat recovery ventilation system.

Application Suitability

The system shall be suitable for use in mid-sized houses with kitchen plus up to five wet rooms and designed primarily for new build and major renovations. The unit shall be capable of being either wall or ceiling mounted. It shall be suitable for installation in an accessible loft or internal cupboard space. It shall be a single person installation with easy commissioning mounted. The unit shall incorporate Ø125 extract and supply spigots.

Motor

The unit shall incorporate an Ultra Low Watt EC backward curved motor to provide the lowest possible

SFP and unit running costs with sealed for life ball bearings and designed to operate continuously at a pre-set 'background' rate.

Fan

EC motors shall power the centrifugal backward curved fan impellers.

Mechanical Summer Bypass

The automatic, integral mechanical summer by-pass shall ensure that cooler air enters the property on warmer days, creating an ideal indoor climate.

Heat Exchange Cell

The heat exchange cell shall be a high efficiency counter flow cell capable of up to 89% efficiency.

Filtration

The unit shall be supplied with 2 x ISO Coarse 45% filters that can easily be accessed for cleaning or replacing.

Servicing / Maintenance

EnviroVent recommend that units should be serviced annually to maintain optimal performance and that filters should be checked regularly and cleaned as and when required.

Warranty

The EnviroVent EnergiSava 200 units are covered by a parts only 2-year warranty. Please note that conditions and exclusions apply to the warranty which can be found at www.envirovent.com/warranty

Controls

The unit shall be fitted with automatic Intellitrac® humidity controls, with a switch live option. It shall also come supplied with a remote control to adjust the unit's airflow between trickle, boost and third speed rates, including a summer by-pass, filter change and fault indicator.

Manufacturer

Unit shall be the energiSava® 200 as manufactured by EnviroVent Ltd.

Accreditation

SAP PCDB Listed

Conforms to the requirements of the UK Building Regulations and the Technical Standards for Ventilation

Conforms to requirements of the EC council directives relating to Electromagnetic Compatibility and Electrical Safety (LDV and EMC)

CE Marked.

Installation

Full installation guide shall be enclosed with all products; or sent separately in advance if required.

Dimensions (mm)

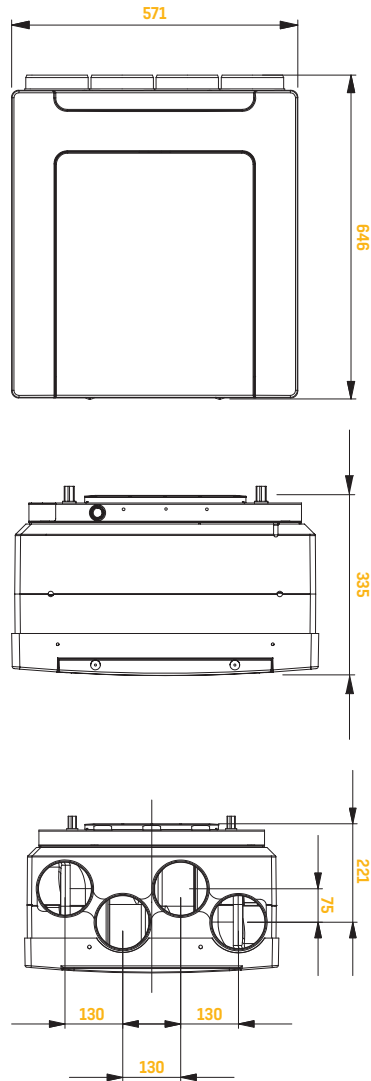

Performance Curve

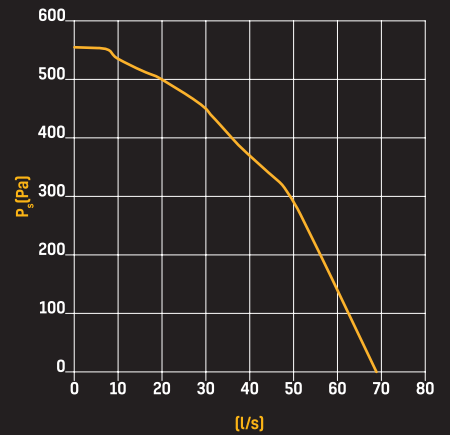

Options & Ancillaries

| DESCRIPTION | CODE(S) |
|--|--------------------------------------|
| 5 IN 1 ROOF VENT KIT | 1RVVENTSIN1KIT1 |
| Ø125MM FLEXIBLE INSULATED HOSE DUCTING | 1RD INS FLEX 125 |
| Ø125MM ACOUSTICALLY INSULATED ALUMINIUM HOSE DUCTING | 1RD ACO FLEX 125 |
| Ø125MM RIGID DUCTING | 1RD 125 X 350MM 1RD 125 X 2M |
| SLIMLINE AIRBRICK (AVAILABLE IN WHITE, TERRACOTTA, BROWN AND COTSWOLD STONE) | 1AC HOR LOUV |
| WHITE POWDER-COATED METAL CEILING VALVES (EXTRACT AND SUPPLY) | 1DIF EXTRACT 125 1DIF SUPPLY 125 |
| FLAT CHANNEL DUCTING | 1FD 204 X 60 1.5M 1FD 204 X 60 2M |



envirovent®

Leaders in the manufacture of innovation and sustainable ventilation

EnviroVent Ltd
Harrogate West Business Park
Unit 1 Bardner Bank
Killinghall, Harrogate
HG3 2SP

T / 01423 810 810
E / enquiries@envirovent.com
W / www.envirovent.com

Due to our policy of continuous innovation and improvement, EnviroVent reserves the right to alter products specification and appearance without notice.

E&OE | MKT ENV441 - V10 - 02/12/2025

Copyright © EnviroVent Ltd 2025



Follow us on
facebook



Follow us on
Instagram



Watch us on
Youtube



Find us on
LinkedIn



Scan
Me

