

TECHNICAL DATA SHEET Cyclone 8 | WC, Bathroom & Kitchen Fan



8
YEAR

DC
M

IPX4
RATED

IPX5
SELV

PRODUCT

Innovative centrifugal extract fan unit which has been designed to deliver a low maintenance, easy to use and low energy ventilation solution which is suitable across all wet rooms in the property.

APPLICATION SUITABILITY

Can be wall, ceiling, window or duct mounted to comply with current Building Regulations. The one fan will ventilate any domestic kitchen, utility room or bathroom and is supplied in a 230V or SELV format.

MOTOR

Incorporates the Ultra Low Watt DC motor technology with sealed for life ball bearings designed to operate continuously at a pre-set 'background' rate.

SERVICING / MAINTENANCE

Achieved by removal/exchange/replacement of central cartridge. Rear carcass remains in position ensuring minimal disruption to occupier and no electrical competence or redecoration required. The fan can be cleaned by removing the quick release impeller.

WARRANTY

Covered by an on-going, repeatable 8 year warranty*, subject to the completion of specified maintenance.

CONTROLS

Continuous running 2-speed filterless fan with integral variable speed and Intellitrac® humidity tracking system. The fan should either have a pullcord override, or the IQ wireless version for odour control.

The fan incorporates a datalogging function which enables the collection of data such as the total running time at both the lower and higher speeds, the time that the fan has spent in periods of increased humidity and the energy that has been used.

KEY FEATURES

- ✓ Datalogging function
- ✓ Variable speed via 25 increments
- ✓ Building regulation compliant
- ✓ Unique patented cartridge system
- ✓ Filterless technology
- ✓ Ultra Low Watt motor technology
- ✓ Patented helical power expansion chamber
- ✓ Automatic vapour tracking function
- ✓ SELV models available
- ✓ 8 year warranty
- ✓ Designed for the life of the building
- ✓ Versatile and flexible
- ✓ Ideal for all applications
- ✓ Environmentally friendly
- ✓ Low maintenance
- ✓ Low life-cycle costings
- ✓ Easy to clean
- ✓ Whisper quiet running

WIRING

The fan is pre-wired with 1 metre of flexible cable to speed up installation. The SELV version is provided with a short length of low voltage cable.

ACCREDITATIONS

Conforms to the requirements of the UK Building Regulations and the Technical Standards for Ventilation.

UKCA and CE marked

*Unit must be in warranty during service and cartridge change.

TECHNICAL DATA SHEET

Cyclone 8 | WC, Bathroom & Kitchen Fan

SIZE (MM)

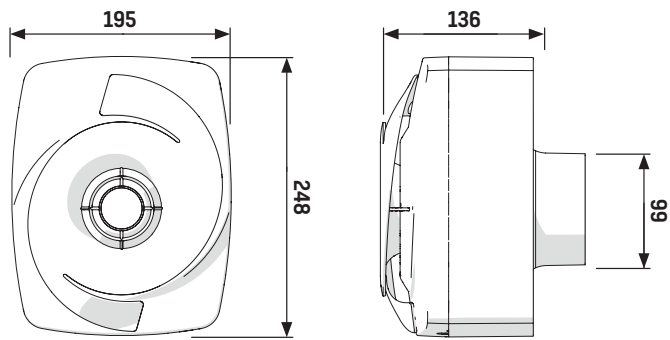

PERFORMANCE CURVE

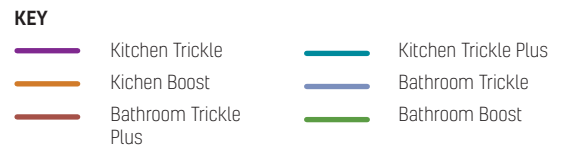
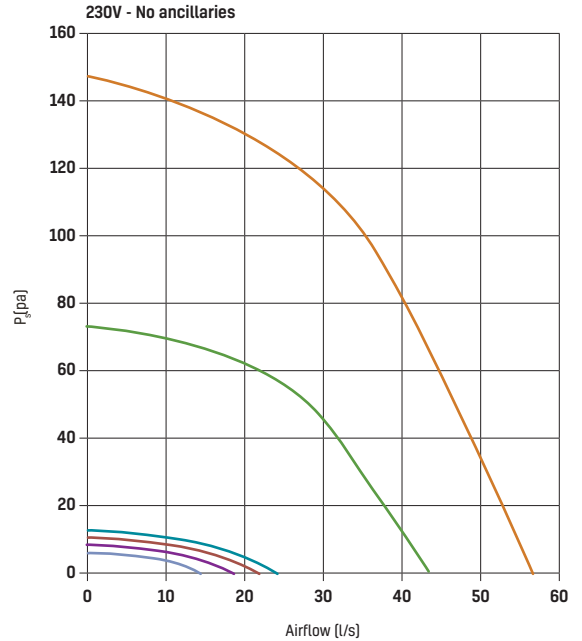

PERFORMANCE & SOUND LEVELS*

Airflow Performance - 230V

Settings	Power (W)	Duty (l/s)	Sound dB(A) @ 3m
Bathroom Trickle	3	14	12.72
Bathroom Trickle+	4	21	19.37
Bathroom Boost	14	41	34.96
Kitchen Trickle	3	19	16.52
Kitchen Trickle+	4	22	19.18
Kitchen Boost	30	55	45.26

Airflow Performance - SELV

Settings	Power (W)	Duty (l/s)	Sound dB(A) @ 3m
Bathroom Boost	14	37	34.96
Bathroom Trickle	3	14	12.72
Bathroom Trickle+	4	21	19.37

*Performance under free air condition (0Pa). These figures are based on factory settings & are subject to change when the datalogging & variable speed function are used. The power consumption is based on internal testing and has a tolerance of +/- 10%

