

envirovent®

energiSava 300 & 400

INSTALLATION GUIDE FOR
ENGINEER / INSTALLER



01 Safety Instructions

IMPORTANT

Be sure to have read and understood these instructions before beginning the installation process.

PRE-INSTALLATION CHECK LIST

Make sure that the unit can physically fit in to the desired location.

This product is not suitable for use with a Type AC RCD 

SAFETY AND RECOMMENDATIONS

- This appliance can be used by children aged from 8 years and above and persons with reduced physical, sensory or mental capabilities or lack of experience and knowledge if they have been given supervision or instruction concerning use of the appliance in a safe way and understand the hazards involved. Children shall not play with the appliance. Cleaning and user maintenance shall not be made by children without supervision.

Installation must take place under:

- Quality requirements ventilation systems in dwellings.
- Quality requirements balanced ventilation in dwellings.
- The regulations for ventilation of dwellings and residential buildings.
- The safety regulations for low-voltage installations.
- The regulations for connection to interior sewers in dwellings and residential buildings.
- Any additional regulations of the local utilities.
- The installation instructions for the energisava 300 & 400

02 Technical Specifications

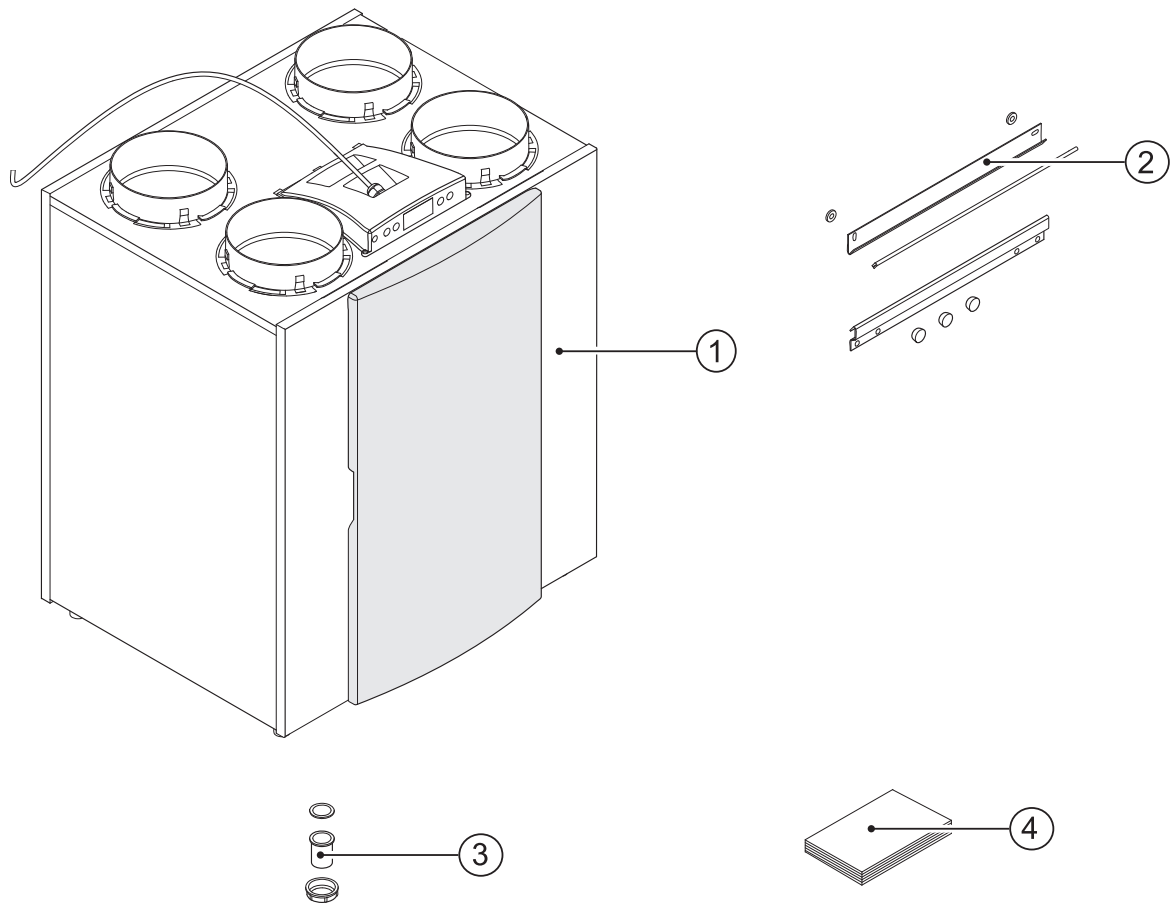

Before you begin to install the heat recovery unit, check that it has been supplied complete and undamaged.

The energisava 300 & 400 units should include the following components:

1. Heat recovery appliance type energisava 300 & 400
2. Wall mounting bracket kit containing:
 - 2 x suspension strips
 - 3x protective caps
 - 1 x rubber strip
 - 2 x rubber rings
 - 1 x mounting instructions
3. PVC condensate discharge connection containing:
 - 1 x synthetic screw gland 1.5"
 - 1 x sealing ring
 - 1 x PVC glued coupling 32 mm
4. Documentation set consisting:
 - 1 x installation instructions

AFTER INSTALLING THIS UNIT PLEASE PASS ONTO END USER
DO NOT THROW AWAY

02 Technical Specifications

The energiSava 300 & 400 are ventilation units with heat recovery incorporating a high efficiency heat exchange cell, a maximum ventilation capacity of 300 or 400 m³/h and low-energy fans.

Features:

- Steplessly adjustable air flow rates through a control panel;
- Filter indication on the appliance and the possibility for filter indication on the multiple switch;
- A completely new intelligent frost protection system. This ensures that even at low outdoor temperatures the appliance's performance remains optimal and that, if necessary, it activates the standard preheater.
- Low sound level
- Comes as standard with automatic bypass valve
- Constant flow control
- Low energy consumption
- High efficiency

The energiSava 300 & 400 are available in two types:

- Standard version
- Plus version

Compared to the standard version, the Plus version has a more extensive control board which increases the connection options.

These installation instructions describe both the standard and the Plus versions.

The Plus version is available in the left-handed or right-handed version. A left-handed version has the filters on the left behind the filter door; a right-handed version has the filters on the right behind the filtered door. The position of the air ducts differs for these two versions. For the correct position of the connection ducts and dimensions [see pages 9-10].

When ordering an appliance always state the correct type; subsequent conversion to a different version is not possible.

The energiSava 300 & 400 comes ready to wire into the 230V mains fuse spur and has a connection for a low-voltage multiple switch on the outside of the appliance.

02 Technical Specifications

Version types energiSava 300 & 400				
Type	Version L or R	Position air ducts	Power supply	Type code
energiSava 300 & 400 [standard version]	Left-handed version	4 top connections	Power cable	4/0 L
	Right-hand version	4 top connections	Power cable	4/0 R
energiSava 300 & 400 [Plus version]	Left-handed version	4 top connections	Power cable	4/0 L+
	Right-hand version	4 top connections	Power cable	4/0 R+

02 Technical Specifications

energiSava 300				
Supply voltage [V/Hz]	230/50			
Protection degree	IP30			
Dimensions (w x h x d) [mm]	677 x 765 x 564			
Duct diameter [mm]	Ø160 / Ø150			
External diameter condensate discharge [mm]	Ø32			
Weight [kg]	38			
Filter class	G3 [F7 optional for supply]			
Fan setting [factory setting]		1	2	3
Ventilation capacity [m³/h]	50	100	150	225
Permissible resistance ducts system [Pa]	3 - 7	11 - 28	26 - 66	56 - 142
Rated power [excl. preheater] [W]	9.0 - 9.2	13.7 - 15.2	22.0 - 29.2	46.8 - 66.2
Rated current [excl. preheater] [AA]	0.104 - 0.107	0.150 - 0.161	0.214 - 0.274	0.403 - 0.578
Max. rated current [with preheater switched on] [A]	6			
Cos	0.368 - 0.374	0.391 - 0.416	0.447 - 0.463	0.505

Sound Power energiSava 300									
Ventilation capacity [m³/h]		90		150		210		300	
Sound power level Lw [A]	Static pressure [Pa]	50	100	50	100	50	100	50	100
	Housing emission dB[A]	30	33	38	38	44	46	50	52
	Duct from dwelling dB[A]	33	34	39	42	45	46	54	54
	Duct to dwelling dB[A]	44	47	52	55	60	60	67	67
In practice, the value may deviate 1 dB[A] as a result of measuring tolerances									

02 Technical Specifications

energiSava 300 fan graph

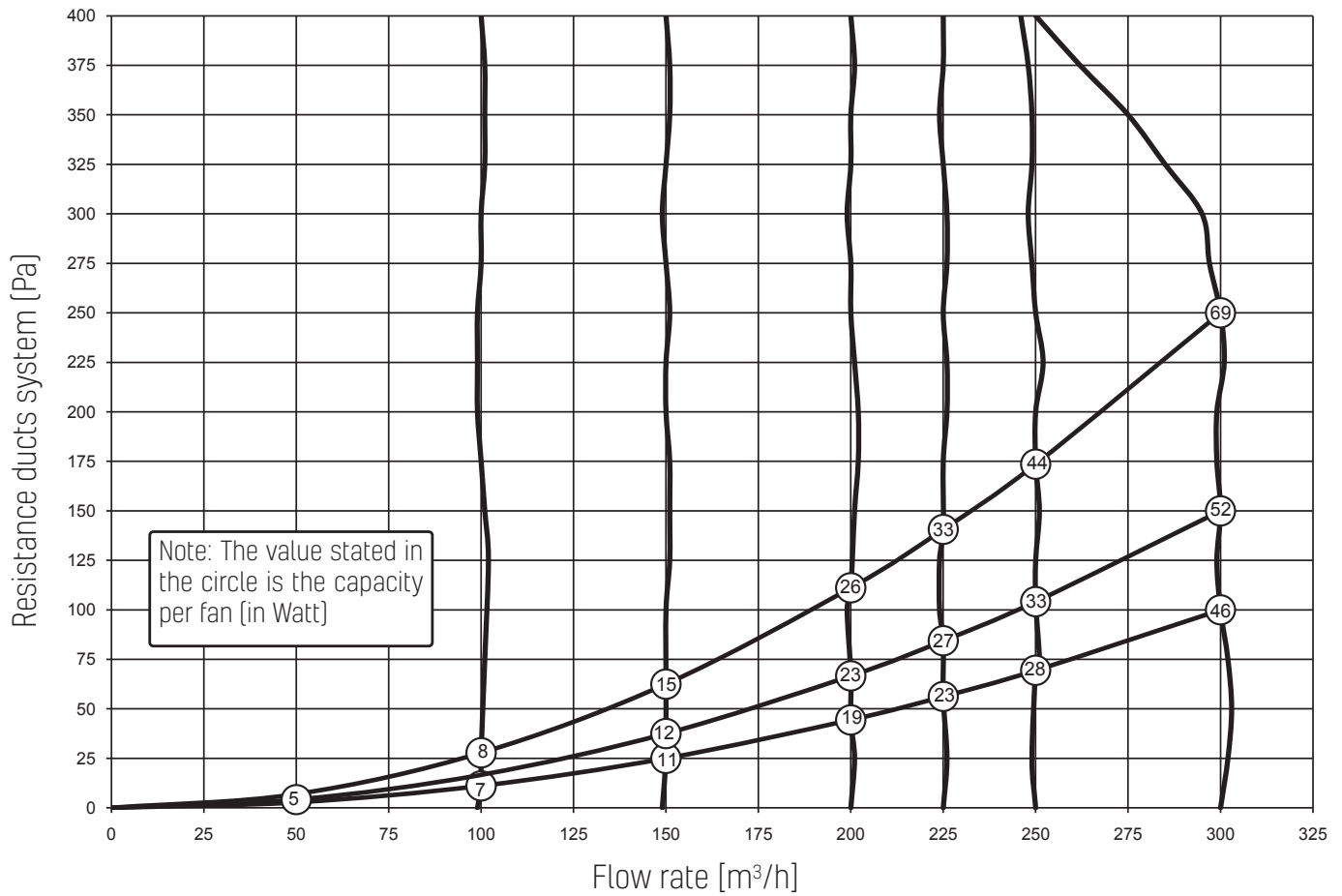

AFTER INSTALLING THIS UNIT PLEASE PASS ONTO END USER
DO NOT THROW AWAY

02 Technical Specifications

energiSava 400				
Supply voltage [V/Hz]	230/50			
Protection degree	IP30			
Dimensions (w x h x d) [mm]	677 x 765 x 564			
Duct diameter [mm]	Ø180			
External diameter condensate discharge [mm]	Ø32			
Weight [kg]	38			
Filter class	G3 [F7 optional for supply]			
Fan setting [factory setting]		1	2	3
Ventilation capacity [m³/h]	50	100	200	300
Permissible resistance ducts system [Pa]	3 - 6	6 - 20	25 - 79	56 - 178
Rated power [excl. preheater] [W]	8.6	9.5 - 15.0	29.0 - 40.0	72.0 - 98.0
Rated current [excl. preheater] [AA]	0.10	0.12 - 0.14	0.24 - 0.31	0.51 - 0.70
Max. rated current [with preheater switched on] [A]	6			
Cos	0.38	0.45 - 0.40	0.56 - 0.58	0.60 - 0.61

Sound Power energiSava 400												
Ventilation capacity [m³/h]		100		200		225		300		400		
Sound power level Lw [A]	Static pressure [Pa]	9	40	38	80	47	100	84	175	240	150	225
	Housing emission dB[A]	29.5	32.5	40.5	40.5	43.5	47.5	51.0	53.0	54.0	54.5	57.0
	Duct from dwelling dB[A]	31.5	34.5	46.5	48.0	48.5	50.0	56.5	57.0	58.0	59.0	60.0
	Duct to dwelling dB[A]	42.5	47.5	57.0	59.0	60.5	62.5	66.0	68.5	69.5	70.5	71.5
In practice, the value may deviate 1 dB[A] as a result of measuring tolerances												

02 Technical Specifications

energiSava 400 fan graph

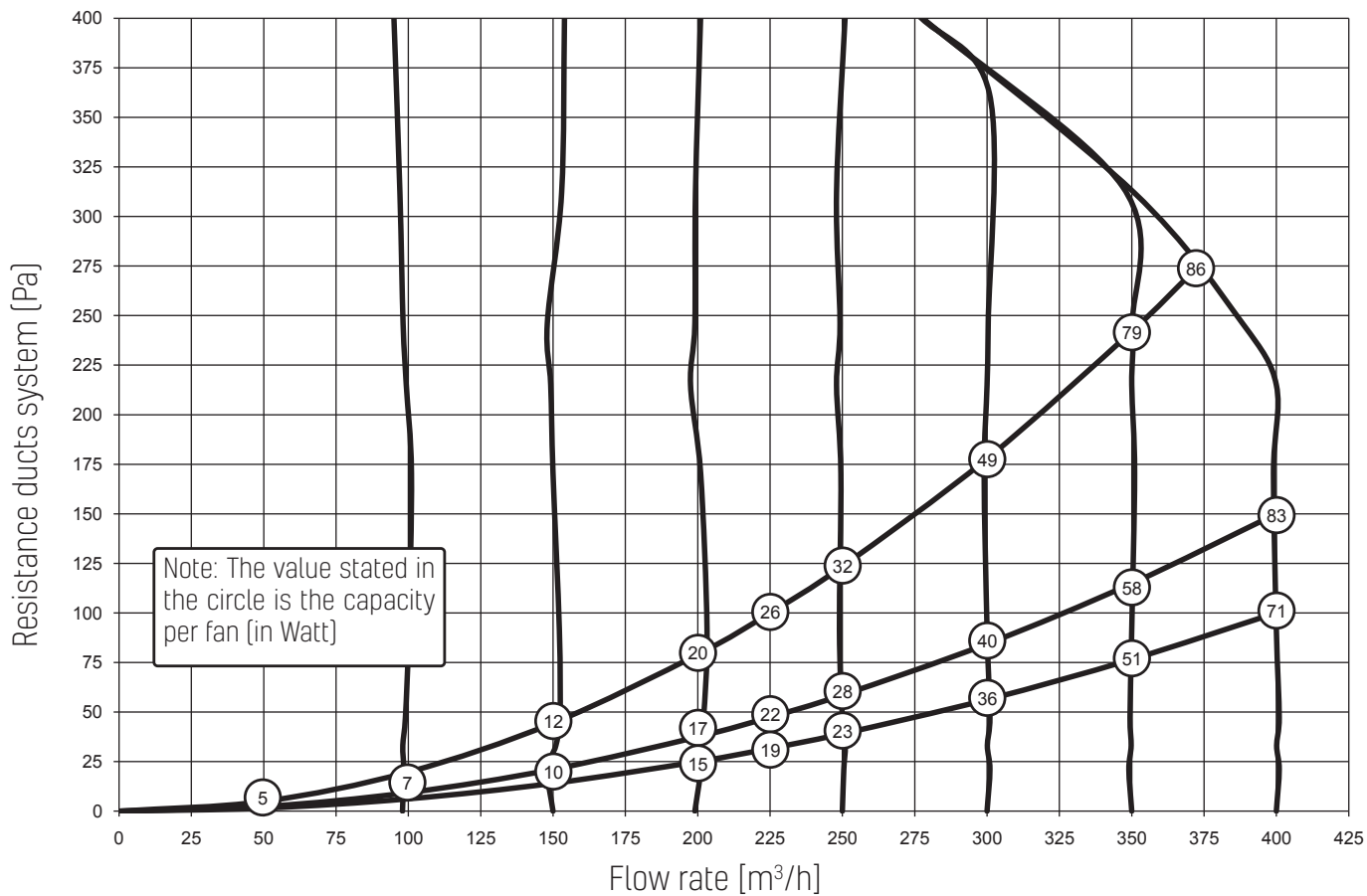

AFTER INSTALLING THIS UNIT PLEASE PASS ONTO END USER
DO NOT THROW AWAY

02 Technical Specifications

Connections & dimensions - Right handed version

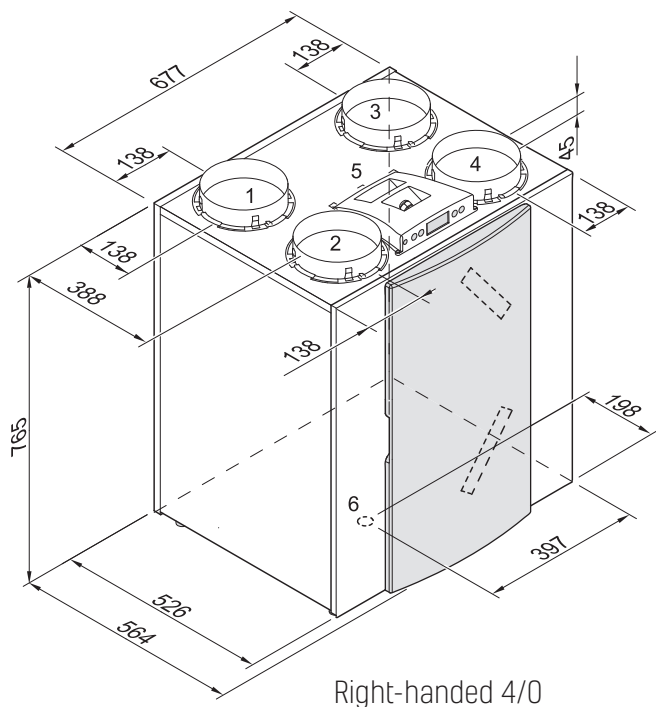

1. To dwelling	
2. To atmosphere	
3. From dwelling	
4. From atmosphere	
5. Electric connections	
6. Connection condensate discharge	
7. Wall mounting bracket (note the correct position of the rubber strip, washers and caps)	

02 Technical Specifications

Connections & dimensions - Left handed version

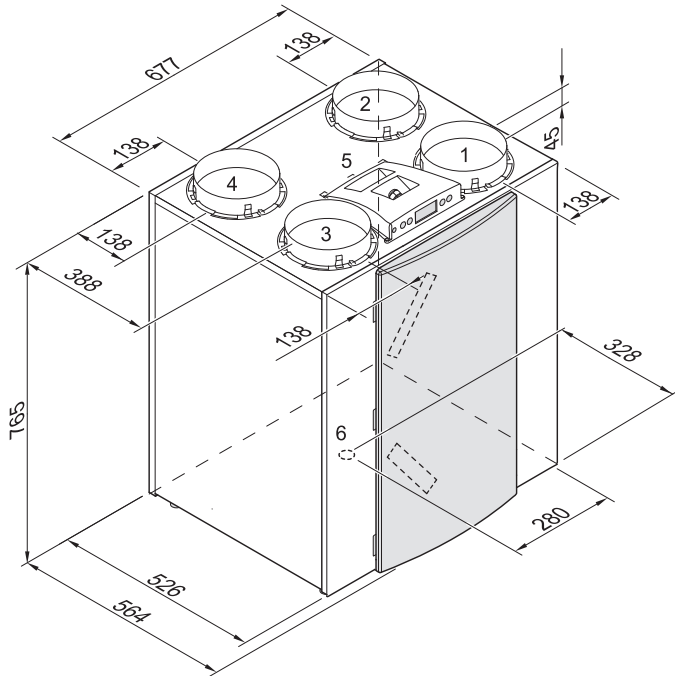

Left-handed 4/0

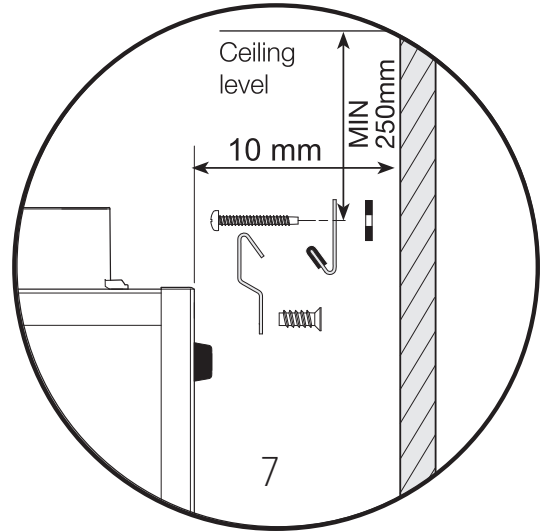

Mounting wall suspension kit

AFTER INSTALLING THIS UNIT PLEASE PASS ON TO END USER
DO NOT THROW AWAY

02 Technical Specifications

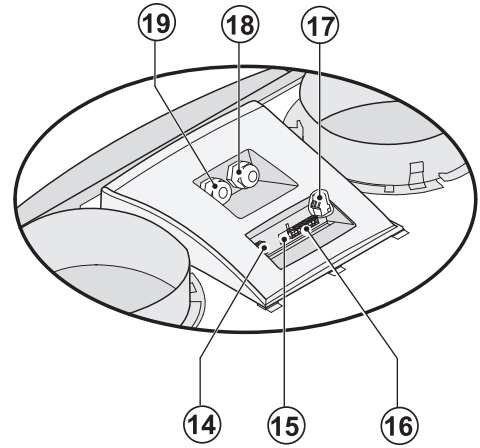
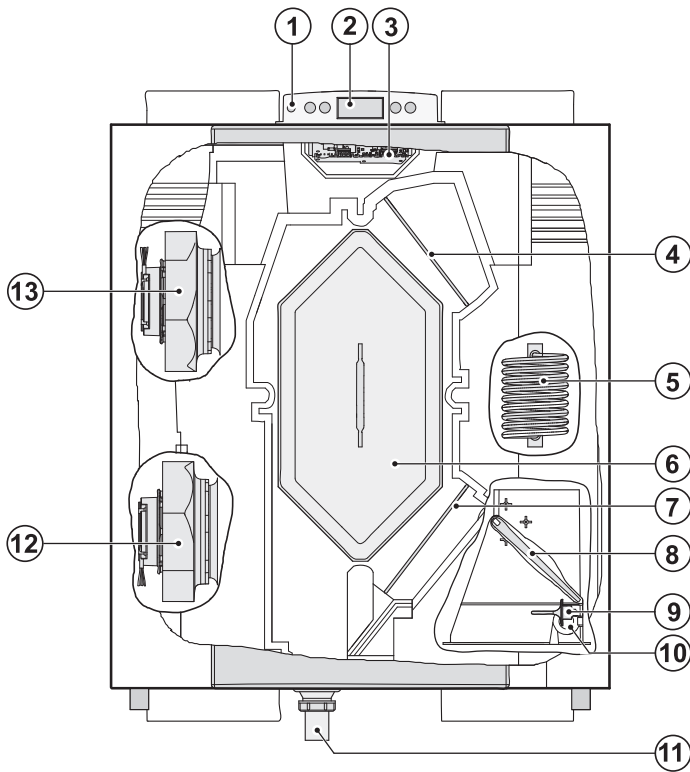

Rear view display cover
(Plus version)

1	Service connector	Computer connection for service purposes
2	Display and 4 control buttons	Interface between user and control electronics
3	Control board	Contains the control electronics for the basic functions
4	Extract air filter	Filters air flow from dwelling
5	Preheater	Heats up the outdoor air when there is a risk of freezing in the heat exchanger
6	Heat exchanger	Ensures heat transfer between input and output air
7	Supply air filter	Filters outdoor air supplied to the dwelling
8	Bypass valve	Sends the air through or around the heat exchanger [For 4/0 this valve is in the upper part of the appliance]
9	Outdoor temperature sensor	Measures outside air temperature
10	Indoor temperature sensor	Measures the dwelling air temperature
11	Condensate discharge	Connection condensate discharge [Kit comes separately with the appliance]
12	Extract fan	Discharges air from the dwelling to the atmosphere
13	Supply fan	Feeds fresh air into the dwelling
14	Modular connector multiple switch X2	Connections for cable to multiple switch, if desired with filter indicator
15	Connector eBus X1	Connection for eBus control
16	Connector X15	Contains the various control inputs and outputs; only for Plus version
17	Connector X14	Connection postheater; only for Plus version [accessible after taking off the display cover]
18	Mains cable 230V	Gland power cable 230V
19	Connection to postheater	Gland 230V cable to postheater or extra preheater; only for Plus version

02 Technical Specifications

The appliance is supplied ready to wire into the fuse spur and operates fully automatically. The extracted indoor air heats up the fresh, clean outdoor air. That saves energy and fresh air is sent to the required rooms.

The control system has three ventilation modes. The air flow rate can be adjusted per ventilation mode. The constant volume control system ensures that the air flow rate of the supply and extract fans is always delivered despite any resistance encountered in the ductwork.

The standard bypass valve makes it possible to supply fresh outside air that is not heated by the heat exchanger. Particularly during summer nights it is desirable to supply cooler outside air. In this mode the hot air in the dwelling is replaced by cooler outside air as far as possible.

The bypass valve opens and closes automatically when a number of conditions are satisfied (refer to the table below for bypass conditions).

The operation of the bypass valve can be adjusted in step number 5, 6 and step number 7 in the settings menu (see page 41).

To prevent freezing of the heat exchanger at extremely low outdoor temperatures, the energisava 300 & 400 features an intelligent frost control. Temperature sensors measure the temperatures across the heat exchanger and, if necessary, the preheater is switched on. This guarantees a proper ventilation balance, even at very low outdoor temperatures.

Bypass valve open	<ul style="list-style-type: none"> -The outdoor temperature is higher than 10°C and -The outdoor temperature is lower than the indoor temperature in the dwelling and -The temperature in the dwelling is higher than the temperature set at step no.5 in the settings menu (set a standard at 24°C).
Bypass valve closed	<ul style="list-style-type: none"> -The outdoor temperature is lower than 10°C or -The outdoor temperature is higher than the indoor temperature in the dwelling or -The temperature from the dwelling is lower than the temperature set at step no. 5 in the settings menu minus the set temperature by the hysteresis (tolerance) (step no. 6), this temperature is factory set at 22°C (24.0°C minus 2.0°C).

02 Technical Specifications

Plus version

The energiSava 300 & 400 are also available as a Plus version. This version is equipped with a different control board with 2 additional connectors (X14 & X15) with more connection options for various applications.

The 9-pole connector X15 is accessible at the rear of the unit display cover without having to open the appliance.

The 2-pole connector X14 is accessible after taking off the display cover. The display cover of the "Plus" version has a second gland. That makes it possible to feed a 230 volt cable, which may be connected to connector X14, to outside the appliance.

See page 33 for more information on the connection possibilities of connectors X14 and X15.

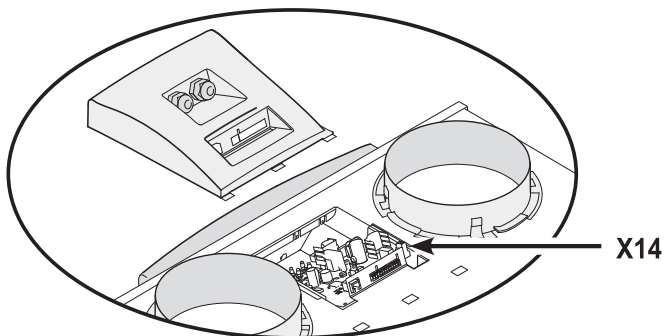
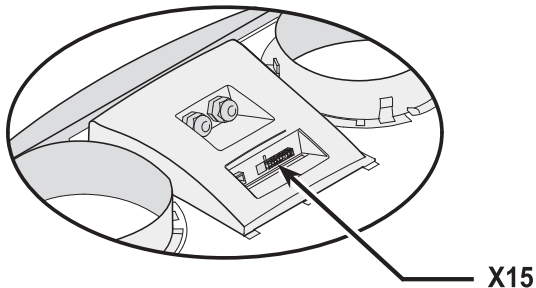

03 Accessories

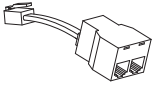
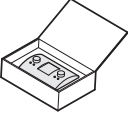
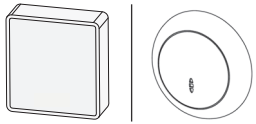
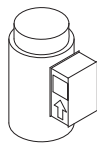
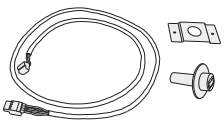
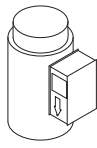
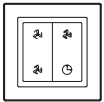
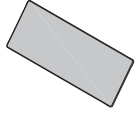
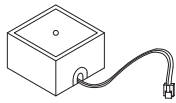
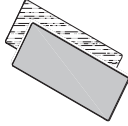
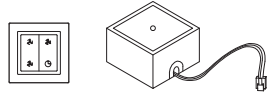
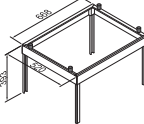
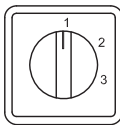
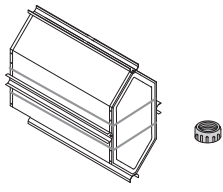
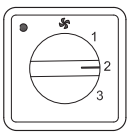
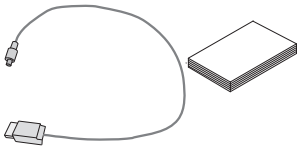
Splitter RJ12		Control unit	
CO ₂ sensor, flush mounted eBus or surface mounted 0-10V proportional (PLUS version only)		Electric postheater energiSava 300 Ø160mm energiSava 400 Ø180mm	
RH sensor		Electric (extra) preheater energiSava 300 Ø160mm energiSava 400 Ø180mm	
Transmitter wireless remote control 4 positions (with. battery)		Filter kit 1 x F7 filter [1 pcs]	
Receiver wireless remote control (for battery version)		Filter kit 1x G3 & 1x F7 [1 pcs/ 1 pcs]	
Kit wireless remote control 4 positions [1 transmitter & 1 receiver]		Mounting support	
3-way switch white flush-mounted (without filter indication) Delivered with insert plate and cover frame		Enthalpie heat exchanger	
4-way switch with filter indication; flush mounted; modular connection. Delivered with insert plate and cover frame		Service tool	

AFTER INSTALLING THIS UNIT PLEASE PASS ONTO END USER
DO NOT THROW AWAY

04 Installation Instructions

Placing the appliance

The energiSava 300 & 400 units can be mounted directly to the wall using the suspension brackets supplied for that purpose. For a vibration-free result the appliance must be mounted to a solid wall with a minimum mass of 200 kg/m². A gypsum block or metal stud wall will not suffice. Additional measures such as double panelling or extra studs are required in that case. On request, a mounting support for floor mounting is available. In addition, the following aspects must be taken into account.

- The appliance must be placed level.
- The installation room must be such that a good condensate discharge with air trap and pitch for condensate can be made.
- The installation room must be frost-free.
- Make sure there is a free space of at least 70 cm at the front of the appliance and a free headroom of 1.8m for cleaning the filters and carrying out maintenance.
- Make sure there is a free space of at least 20 cm above the display cover so it can always be removed.

Connecting the condensate discharge

The condensate discharge line for the units is fed through the lower panel. The condensate must be discharged through a drainpipe. EnviroVent recommend using **KITCONDENSATE-BK**.

Alternatively use a U-trap (sold separately) which the installer must screw it into the underside of the appliance.

This condensate discharge connection has an external connecting diameter of 32 mm.

The condensate discharge line can be glued to it, if necessary using a square bend. The installer can glue the condensate discharge in the desired position in the lower part of the appliance. The drain must discharge under the water level in the U-trap. Before connecting the condensate discharge to the appliance, pour water into the U-trap to create an air trap.

Note: Add a teaspoon of oil to prevent drying out. Alternatively use a non return valve in place of the U-trap.

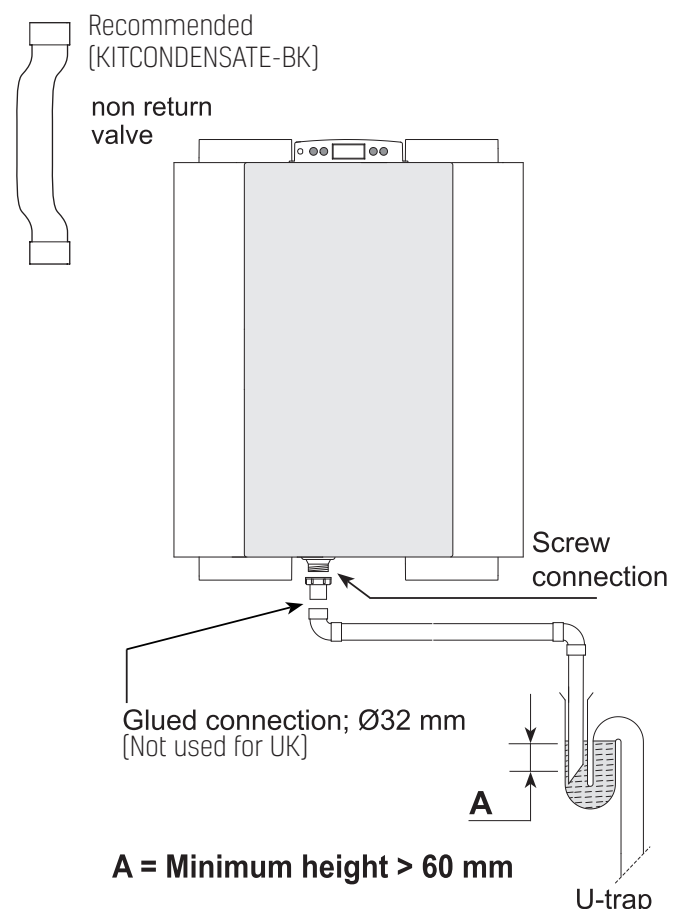

04 Installation Instructions

Connecting ducts

The air extract duct does not have to be fitted with a control valve. The appliance controls the air flow rates itself. To prevent condensation on the outside of the outdoor air supply duct and the air exhaust duct downstream of the units these ducts must be provided with an external vapour barrier as far as the appliance. If thermally insulated piping is used here, additional insulation is not necessary.

For compliance with the maximum installation noise level of 30 dB, each installation will have to be assessed individually and measures put in place if required to limit the noise.

A section of acoustic duct with a minimum length of 0.5m is required, but additional measures may be necessary. Please contact EnviroVent if you have any questions on this subject.

For incorporated ducts pay attention to crosstalk and installation noise. Design the duct with separate branches to the valves to prevent crosstalk. If necessary, the supply ducts must be insulated, for instance when they are installed outside the insulated envelope of the building.

Preferably use EnviroVent incorporated ducts. These ducts have been developed with a view to a low duct resistance.

A duct diameter of 150mm is required for the energisava 400 connecting to the 180mm spigot on the unit. The 400 units are supplied with 4 X duct adaptors. The energisava 300 also requires a 150mm duct connecting to a 160/150mm spigot.

04 Installation Instructions

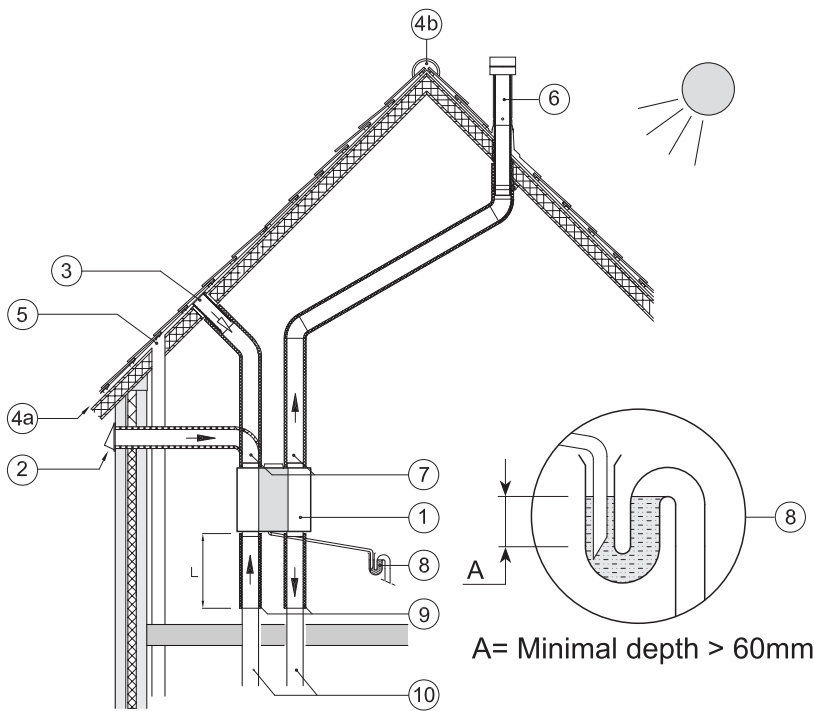

A = Minimal depth > 60mm

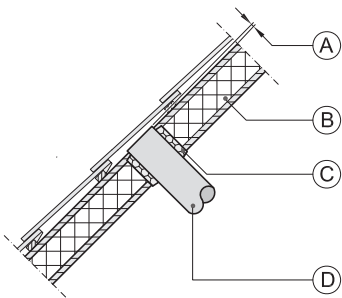

A = Spacing 10 mm above roof deck
 B = Roof insulation
 C = Seal with foam
 D = Pipe for make-up air to be carefully insulated and provided with vapour barrier

- 1=Left-handed 2/2 (place level)
- 2=Preferred ventilation air supply
- 3=Ventilation air supply under the tiles
- 4a=Free suction bottom roof area
- 4b=Free suction top roof area
- 5=Sewer vent
- 6=Preferred location extract ventilation air; use insulated ventilation roof sleeve.
- 7=Thermally isolated pipe
- 8=Condensate discharge with U-trap or non return valve
- 9=Muffler
- 10=Ducts from and to dwelling

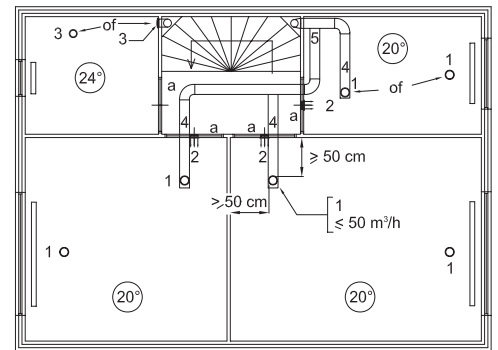

- 1 = EnviroVent supply valves
- 2 = Supply from wall
- 3 = Suction valve in ceiling or high in wall
- 4 = Prevent crosstalk
- 5 = Preferably incorporated ducts
- a = Gap under the door 10mm after finished floor level.

- Arrange the exterior air supply from the shadowed side of the dwelling, preferably from the wall or overhang. If the outdoor air is sucked in from under the tiles, ensure that no condensation develops in the roof boarding and no water can run into the duct. Ventilation air can be sucked in from under the tiles if air can access freely at the top and the bottom of the roof area and the sewage vent stack does not end under the tiles. Preferably use a domed style roof vent with maximum free area for minimum resistance.
- Feed the extract duct through the roof boarding in such a manner that no condensation develops in the roof boarding.
- Install the extract duct between the unit and the roof sleeve in such a manner that surface condensation is prevented.
- Always use an insulated ventilation roof sleeve.
- The maximum permissible resistance in the duct system is 150 Pa at the maximum ventilation capacity. If the resistance of the duct system is higher, the maximum ventilation capacity will be lower.
- The location of the mechanical ventilation output and the sewer stack vent relative must be chosen to prevent nuisance.
- Choose the location of the supply valves to prevent fouling and draught. We recommend to use the EnviroVent supply valves.
- When mounting flexible ducts, bear in mind that it must be possible to replace them in due course.
- Flexible duct must be kept to a minimum.

04 Installation Instructions

Connecting the power

The appliance can be connected to an easily accessible fused spur with the cable running from the appliance. The electric installation must comply with the wiring regulations.

Make allowance for the 1000 W preheater.

Connecting the multiple switch

The multiple switch (not supplied with the appliance) is connected to the modular connector type RJ12 (connector X2) that is placed at the rear of the appliance's display cover.

Dependent on the type of multiple switch that is used, a plug RJ11 or RJ12 can be connected to it.

- Application of a 4-way switch with filter indication in all cases requires an RJ12 plug in combination with a 6-core modular cable.
- Application of a 3-way switch without filter indication in all cases requires an RJ11 plug in combination with a 4-core modular cable.

Refer to diagrams on page 34 for connection examples multiple switch.

Other options include wireless remote control or a combination of multiple switches.

The 4-way switch can also be used to activate a 30-minutes boost mode by putting the switch to setting 3 for less than 2 seconds and directly turning it back to setting 1 or 2.

The boost mode can be reset by putting the switch to setting 3 for longer than 2 seconds or by switching it to absence mode (☞).

Warning



The fans and control board carry a high voltage. Always remove the voltage from the appliance by isolating power when working on the appliance.

Connecting eBus or OpenTherm connector

The units can operate with OpenTherm as well as with eBus protocol. The setting of parameter 08 in the settings menu (see page 40) lets you choose between eBus and OpenTherm.

An eBus or OpenTherm connection can be made with the 2-pole connector X1 at the rear of the display cover.

The eBus protocol can for instance be used for coupling (cascade control) appliances (see page 35). Because of polarity sensitivity, always connect contacts X1-1 to X1-1 and contacts X1-2 to X1-2 ; the appliance will not work when these contacts are interchanged.

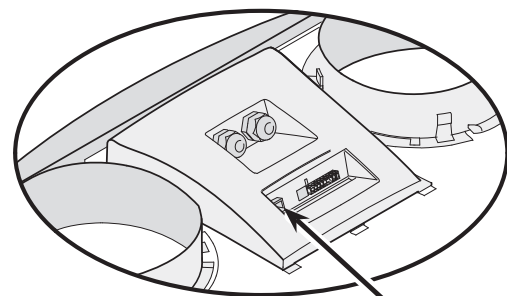

RJ12

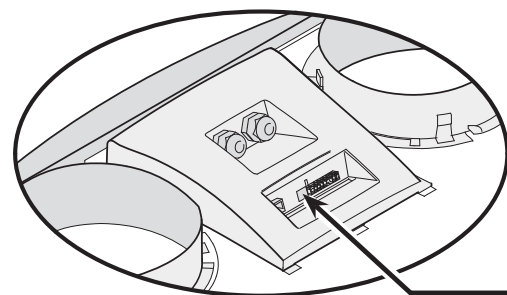

X1

05 Control Display

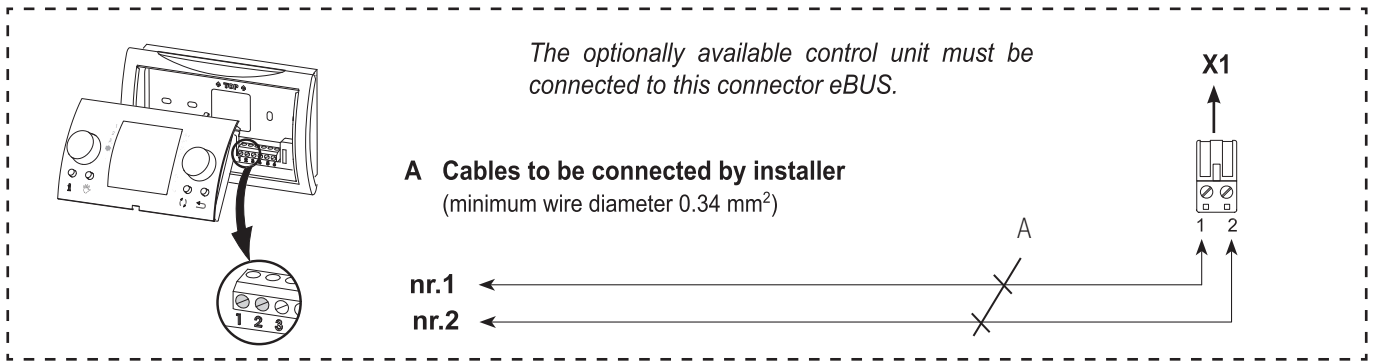

General explanation control panel

The LCD display shows what the operating situation of the appliance is. Four control keys can be used to call up and modify settings in the control unit program.

When the mains power to the unit is switched on, all display symbols will appear for 2 seconds; at the same time the blue backlight is switched on for 60 seconds. When one of the control keys is operated, the display will light up for 30 seconds.

When no keys are operated or when no deviating situation has developed (such as a blocking fault) the display will show the operating mode (see page 20).

After operating the key 'Menu', the keys "+" or "-" can be used to select from three different menus, including:

- Settings menu [SET]; (see page 22)
- Readout menu [READ], (see page 23)
- Service menu [SERV], (see page 24)

Press the R key to leave any menu and return to operating mode. Briefly press the R key (shorter than 5 seconds) to switch on the display backlight without changing anything in the menu.

Key	Function Key
Menu	Activate the settings menu; to the next step in the submenu; confirm value change
-	Scroll; modify value; Switching on or off the unit from operating mode (press for 5 seconds)
+	Scroll; modify value
R	One step back in menu; cancel value modification; filter reset (press for 5 seconds), delete fault history

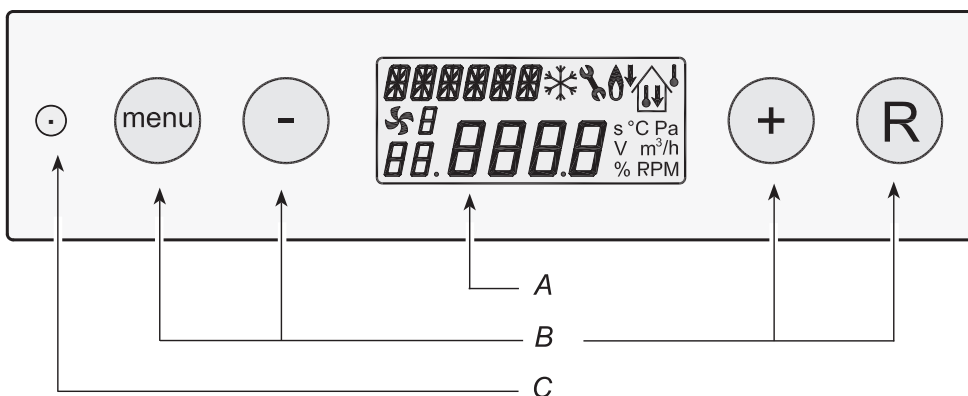

SHOULD YOU ENCOUNTER ANY PROBLEMS INSTALLING THIS UNIT CALL
0345 27 27 810

05 Control Display

Operating mode

In operating mode the display may simultaneously show 4 different situations/values.

- 1= Fan status, image coupled appliances [see page 20]
- 2= Air flow rate [see page 21]
- 3= Message text e.g. text filter situation, activation external switch contact etc. [see page 21]
- 4= Fault symbol [see pages 27 & 28]

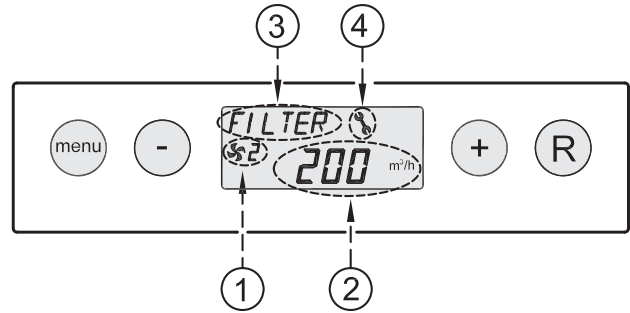

Status system fan

This part of the display shows a fan together with a number. When the supply and extract fans are running, the fan symbol is displayed. When the fans are stopped, the fan symbol is not visible.

The number next to the fan symbol indicates the fan status. Refer to the table below for an explanation of the numbers.

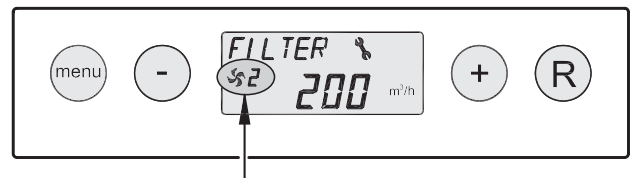

Status fan situation on display	Description
	The supply and extract fans are running at 50 m³/h or are inactive. ¹⁾ This state depends on setting parameter 1 [see page 41]
	The supply and extract fans are running under mode 1 of the multiple switch. Air flow rate depends on setting parameter 2 [see page 41].
	The supply and extract fans are running under mode 2 of the multiple switch. Air flow rate depends on setting parameter 3 [see page 41].
	The supply and extract fans are running under mode 3 of the multiple switch. Air flow rate depends on setting parameter 4 [see page 41].
	The units are coupled with the aid of eBus. The supply and extract fans of the units are running under switched mode of the ventilation mode "master" in addition, [only for cascade connection] the display shows the "slave" number of the relevant. Air flow rate depends on the set parameters "master".

¹⁾ When using a 3-way switch, the position can not be used.

05 Control Display

Display air flow rate

This shows the set air flow rate of the supply or extract fan. When the air flow rates of the supply and extract fans differ, for instance when using an external switch contact, in all cases the highest air flow rate is shown. When the appliance is switched off through software, the text "OFF" appears here.

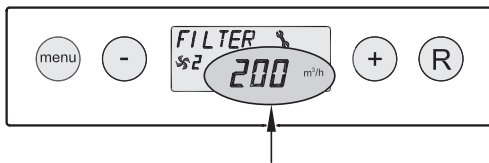

Message text for operating mode

This part of the display may show a message text. The message text "Filter" always takes precedence over the other message texts.

The following message text may appear during operating mode.

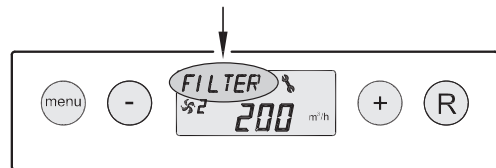

Message text on display	Description	
FILTER	When the text "FILTER" appears on the display, the filter must be cleaned or replaced; for detailed information, see page 29.	
Slave 1, Slave 2 etc.	For coupled appliances the message text shelves which appliances "Slave 1" - "Slave 9"; for detailed information, see page 35. The "Master" appliance displays the regular image regarding ventilation mode.	
EWT (only on Plus version)	When the text "EWT" appears on the display, the geo heat exchanger is active. For extensive information, also see page 37.	
CN1 or CN2 (only on Plus version)	When the text "CN1 or CN2" appears on the display, one of the external switch inputs is active, also see page 38.	
V1 or V2 (only on Plus version)	When the text "CN1 or CN2" appears on the display, one of the external 0 - 10 V. inputs is active, also see page 39.	

05 Control Display

Settings menu

For optimum performance of the appliance, set values can be modified in the settings menu to adjust the appliance to the installation situation; refer to pages 41-43 for a list of the set values. A number of set values, such as the air flow rates, are laid down in the design data.

Warning:

Because changes may affect the optimum performance of the appliance, changes of settings not described here require consultation with EnviroVent. Incorrect settings may seriously affect the optimum performance of the appliance.

Modifying the set value in the settings menu:

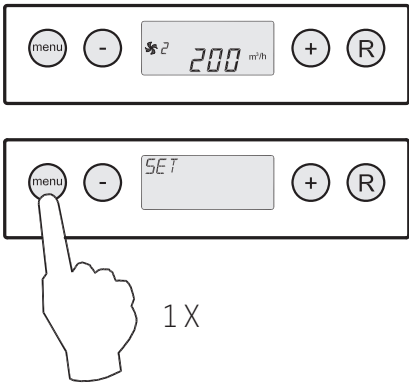
1. In operating mode, press the 'MENU' key
 

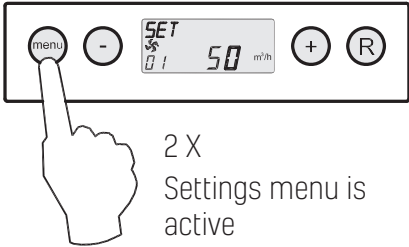
1 X
2. Press the 'Menu' key to activate the settings menu
 

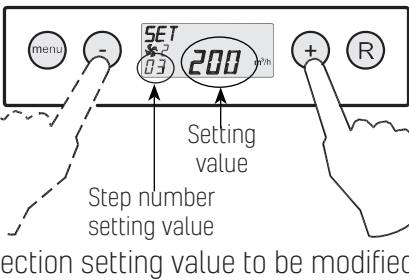
2 X
Settings menu is active
3. Select the set value to be modified with the '+' or '-' key
 

Setting value
Step number setting value
Selection setting value to be modified

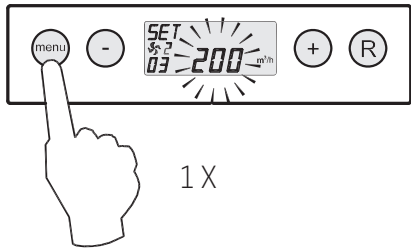
4. Press the 'Menu' key to select the required set value
 

1 X

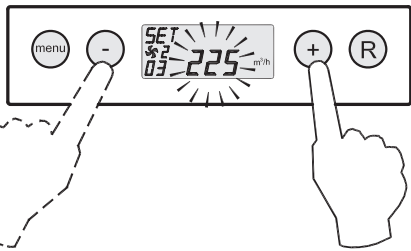
5. Use keys '-' and '+' key to modify selected set value
 

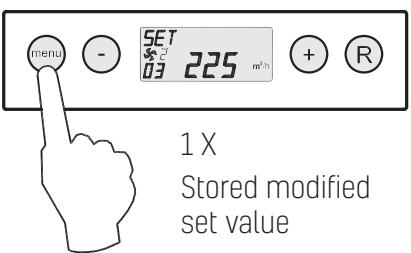
6. Store modified set value
 

1 X
Stored modified set value

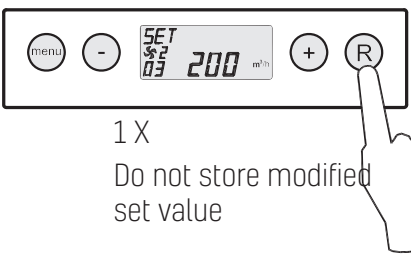
6. Do not store modified set value
 

1 X
Do not store modified set value

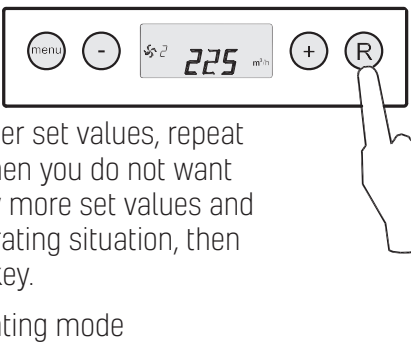
7. To modify other set values, repeat step 3 - 6. When you do not want to modify any more set values and return to operating situation, then press the 'R' key.
 

Back to operating mode

05 Control Display

Readout menu

The readout menu can be used to call up a number of current sensor values to obtain more information on the appliance's performance. Modifying values of settings is **not** possible in the readout menu. The readout menu can be displayed as follows.

1. In operating mode, press the 'MENU' key. Now the display shows the settings menu.



Operating mode



Settings menu

2. Use the '+' and the '-' key to go to the readout menu.

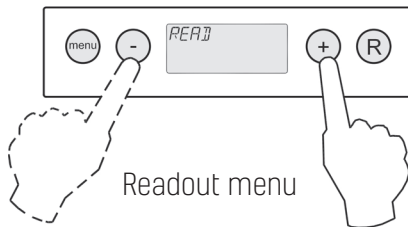

Readout menu

3. Activate the readout menu.

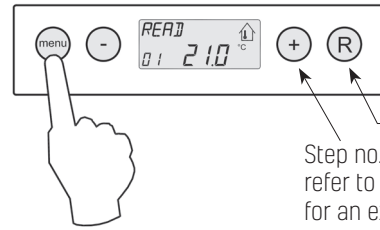

Readout value
Step no. readout value;
refer to the table below
for an explanation

4. Use the '+' and the '-' key to scroll through the menu.

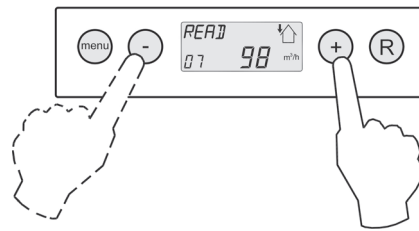

5. Press the 'R' key twice to go back to operating mode. If no key is operated for 5 minutes, the appliance automatically returns to operating mode.



2 X
Operating mode

Step no. readout value	Description readout value	Unit
01	Current temperature from dwelling	°C
02	Current temperature outdoors sensor	°C
03	Bypass status [ON = bypass valve open, OFF = bypass valve closed]	
04	Status frost protection [ON = frost protection active, OFF = frost protection not active]	
05	Current channel pressure supply	Pa
06	Current duct pressure extract	Pa
07	Current air flow rate supply fan	m³/h
08	Current air flow rate extract fan	m³/h
09	Actual relative humidity [optional]	%

05 Control Display

Service menu

The service menu shows the most recent 10 fault messages. In the event of a locking fault, the settings menu and the readout menu are blocked and only the service menu can be opened; Pressing the 'menu' key directly opens the service menu.

The service menu can be displayed as follows.

1. In operating mode, press the 'MENU'- key. The display now shows the settings menu.



Operating mode



Settings menu

2. Use the '+' and the '-' key to go to the service menu.

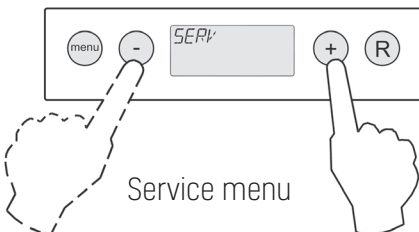

Service menu

3. Activate the service menu.

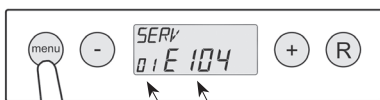

Fault code; [see page for explanation fault code]

No. fault message

4. Use the '+' and the '-' key to scroll through the messages in the service menu.

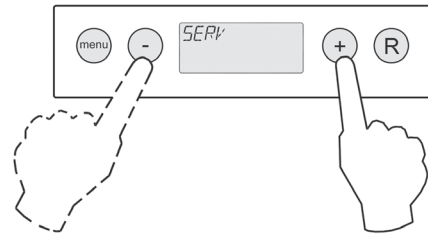

Display NO fault message



Current fault message (spanner on display)



Unsolved fault message [no spanner on display]



5. Press the 'R' key twice to go back to operating mode. If no key is operated for 5 minutes, the appliance automatically returns to operating mode.



2 X
Operating mode

All fault messages can be deleted by pressing the "R" key in the service menu for 5 seconds; This is only possible when there is no active fault.

06 Operation

Switching the appliance ON/OFF

There are two methods to switch the appliance on or off.

- Switching on and off at fuse spur or isolating switch.
- Switching on and off through software on the appliance display.

Switching ON

- Switching on the mains power.
At the fuse spur or isolating switch.

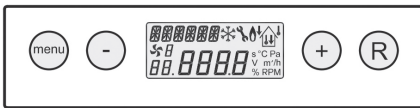

All display symbols appear for 2 seconds.



The software version appears for 2 seconds. Directly after that the unit will run in the mode that is set on the multiple switch. If no multiple switch is connected, the appliance will always run in mode 1.

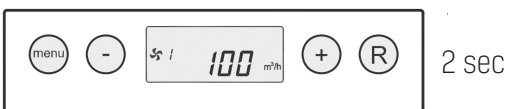

- Switching on through software
When the unit is switched off through software, the display will show the text "OFF".



The appliance can be switched on by pressing the key '-' for 5 seconds.

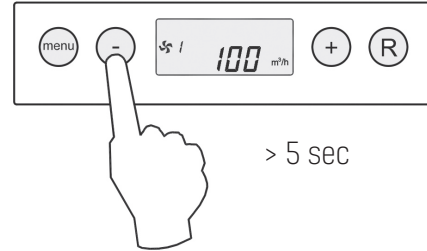

Switching OFF

- Switching off through software
Press the "-" key for 5 sec. to switch off the appliance through software. The text 'OFF' appears on the display.

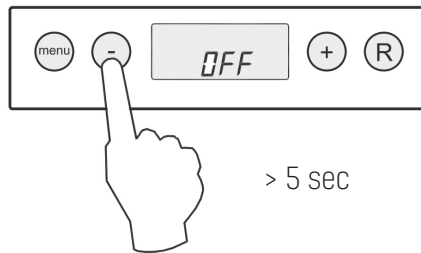

- Switching off the mains power
At either the fuse spur or isolating switch remove voltage from the appliance. Nothing is shown on the display.

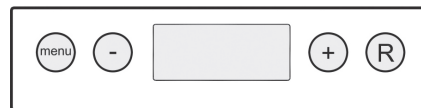

Warning:



When working on the appliance, always remove the voltage from the appliance by first switching it off through software and subsequently disconnecting at the fuse spur.

06 Operation

Setting the air flow rate

The factory supplies the units with the energisava 300 flow rates set to 50, 100, 150 and 225 m³/h and for the energisava 400 set to 50, 100, 200 and 300 m³/h respectively. The performance and the energy consumption of the units depend on the pressure drop in the duct system as well as on the filter resistance.

Important:

Mode  is 0 or 50 m³/h (not in combination with a 3-way switch).

- Mode 1: Must always be lower than mode 2.
- Mode 2: Must always be lower than mode 3;
- Mode 3:
energisava 300 - adjustable between 50 and 300 m³/h;
energisava 400 - adjustable between 50 and 400 m³/h;

If these conditions are not complied with, the air flow rate of the higher mode will automatically be adjusted.

See the settings menu, (see page 22), for changing the flow rates.

Other settings

Various other settings for the units can also be modified. How to modify these is explained is on page 22.

Factory setting

It is possible to reset all modified settings back to factory setting in one go.

All settings will be returned to the values originally supplied with the unit from the factory; all message codes / fault codes will be erased from the service menu as well. The filter notification process will not reset.

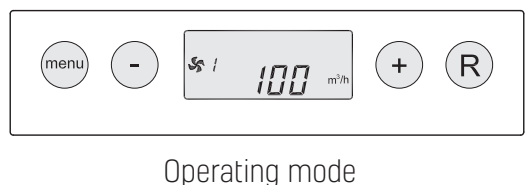
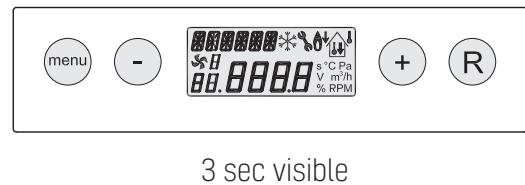
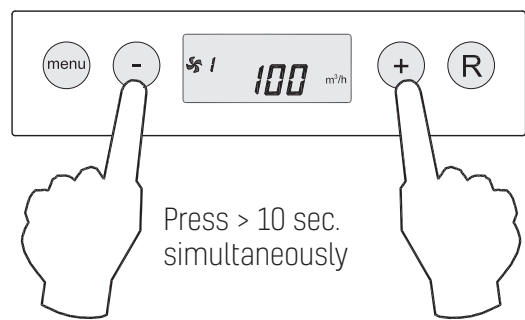

07 Trouble Shooting

When the appliance control system detects a fault, it is indicated on the display with a spanner symbol, possibly together with a fault code.

The appliance makes a distinction between a fault at which the appliance keeps running (limitedly) and a serious (locking) fault at which both fans are switched off. In case of locking fault, the settings and readings menu is switched off as well and only the service menu is available.

The appliance remains in this fault mode until the problem in question has been solved. Then the appliance will reset itself (auto reset) and the display will once more show the operational mode.

The fans are controlled on the basis of the value of the pressure sensors mounted on the control board. For each fan 2 pressure hoses run to the control board. If these hoses are not connected as prescribed, or if they are leaking or blocked, the wrong pressure will be measured so the fans can no longer be controlled correctly. If the performance of the appliance is in doubt, check the pressure hose connections.

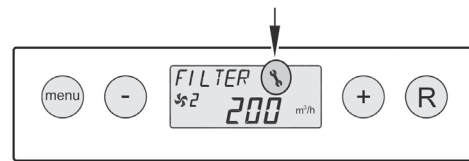

Fault E999

If, when the appliance is powered up directly to message E999 appears on the display, the mounted control board is not suitable for this appliance or the dip switches on the control board are set incorrectly. For the location of the dip switches see page 32.

In that case, check whether the dip switches on the control board are set as shown in the drawing of the dip switches settings; if they are, and the message E999 still appears, then replace the control board with a board of the correct type.

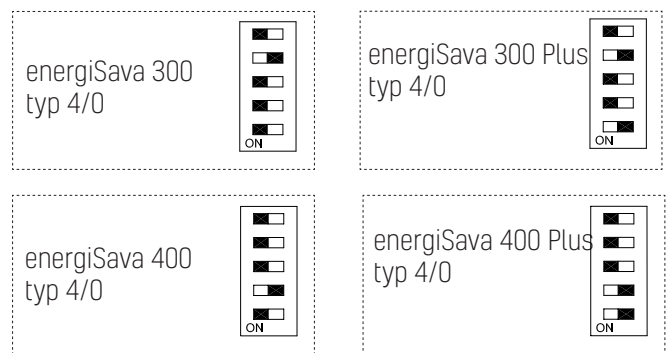

Display codes

Non-locking fault: When the appliance detects a non-locking fault, it will still keep running (limitedly). The display does show the fault symbol (spanner).

Locking fault: When the appliance detects a locking fault, it will no longer work. The (permanently lighted) display shows the fault symbol (spanner) together with fault code. The red LED on the multiple switch (if applicable) will be blinking. Contact the installer to remedy this fault. A locking fault cannot be remedied by removing the voltage from the appliance; the fault must first be solved.

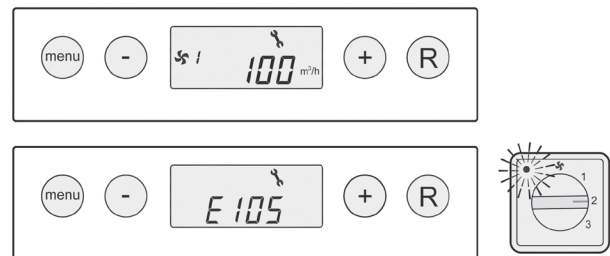

07 Trouble Shooting

Fault Code	Cause	Action Appliance	Action Installer
E100 (non-locking fault)	Pressure sensor supply fan defective. Red pressure hoses blocked or "kinked"	<ul style="list-style-type: none"> Switches to constant rpm control. The preheater switches on at outdoor temperatures below 0°C. 	<ul style="list-style-type: none"> Disconnect unit from power Check the red pressure hoses (and pressure tubes) for fouling, kinking and damage
E101 (non-locking fault)	Pressure sensor extract fan defective. Blue pressure hoses blocked or "kinked"	<ul style="list-style-type: none"> Switches to constant rpm control. The preheater switches on at outdoor temperatures below 0°C 	<ul style="list-style-type: none"> Disconnect unit from power Check blue pressure hoses (and pressure tubes) for fouling, kinking and damage
E103 (non-locking fault)	Bypass fault	<ul style="list-style-type: none"> None. (Current too low stepper motor not correctly connected or effective; current too high short-circuit in wiring or stepper motor) 	<ul style="list-style-type: none"> Disconnect unit from power Check connection stepper motor; replace wiring or stepper motor
E104 (locking fault)	Extract fan defective	<ul style="list-style-type: none"> Both fans are switched off. Preheater is switched off. If applicable: Postheater is switched off. Restart every 5 minutes. 	<ul style="list-style-type: none"> Disconnect unit from power Replace extract fan. Put voltage back on appliance; Fault will automatically be reset. Check cabling.
E105 (locking fault)	Supply fan defective	<ul style="list-style-type: none"> Both fans are switched off. Preheater is switched off. If applicable: Postheater is switched off. Restart every 5 minutes. 	<ul style="list-style-type: none"> Disconnect unit from power Replace Reconnect unit to power; Fault will automatically be reset. Check cabling.
E106 (locking fault)	The temperature sensor that measures the outdoor temperature is defective	<ul style="list-style-type: none"> Both fans are switched off. Preheater is switched off. Bypass closes and is blocked. 	<ul style="list-style-type: none"> Disconnect unit from power Replace temperature sensor Put voltage back on appliance; fault will automatically be reset.
E107 (non-locking fault)	The temperature sensor that measures the temperature of the extract air is defective	<ul style="list-style-type: none"> Bypass closes and is blocked. 	<ul style="list-style-type: none"> Disconnect unit from power Replace indoor temperature sensor
E108 (non-locking fault)	If present: The temperature sensor that measures the external temperature is defective	<ul style="list-style-type: none"> Postheater is switched off. If applicable: Geo heat exchanger is switched off. 	<ul style="list-style-type: none"> Replace external temperature sensor
E111 (non-locking fault)	If present: The RH-sensor that measures the humidity is defective	<ul style="list-style-type: none"> Appliance continues to operate 	<ul style="list-style-type: none"> Disconnect unit from power Replace RH-sensor.
E999 (locking fault)	Dip switches on control board not set correctly.	<ul style="list-style-type: none"> Appliance does nothing; red fault LED on multiple switch is not activated either. 	<ul style="list-style-type: none"> Put dip switches in correct position (see page 32).

Note: If mode 2 of a multiple switch do not work, the modular connector of the multiple switch has been connected the wrong way round. Cut off one of the RJ connectors to the multiple switch and mount a new connector the other way round.

08 Maintenance

Filter cleaning

User maintenance is limited to periodically cleaning or replacing the filters. The filter only has to be cleaned when indicated on the display (it shows the text "FILTER") or, if a multiple switch with filter indication is mounted, when the red LED at the switch lights up.

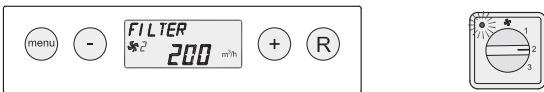

The filters must be replaced every year. It is not permitted to use the appliance without filters.

Cleaning or replacing the filters:

1. Press the '-' key for 5 seconds. Open the filter door.

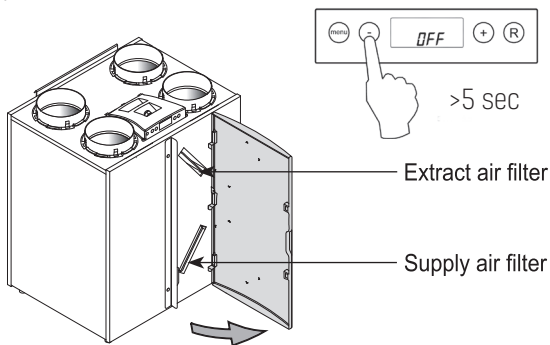

2. Remove the filters. As the filters are different grades, remember the order in which the filters are taken out.

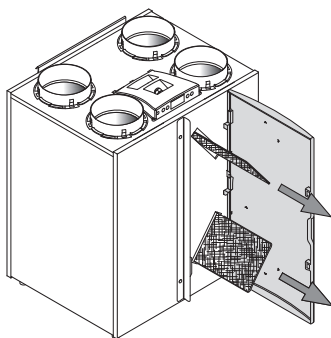

3. Clean or replace the filters.

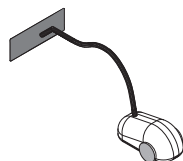

4. Place the filters back the same way as they were taken out.

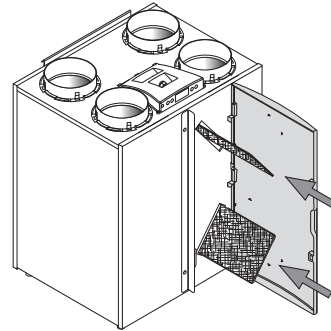

5. Close the filter door. Switch on the appliance by pressing the key '-' for 5 seconds.

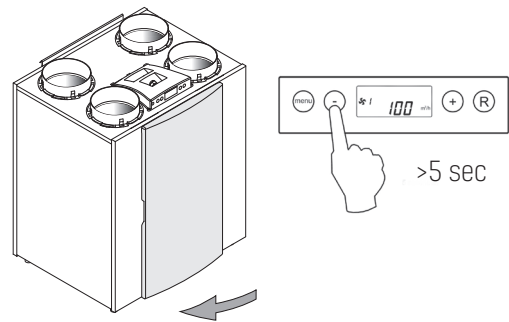

6. After the filters have been cleaned or replaced, press the "R" key for 5 seconds to reset the filter indication. The text "FILTER" will blink briefly to confirm that the filters have been reset. Also when the message "FILTER" has not yet appeared on the display, a filter reset can be carried out; the "counter" will be reset to zero.

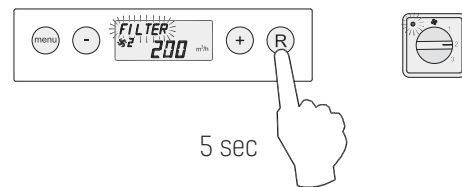

After the filter reset, the text "FILTER"; disappears, the light at the multiple switch is off and the display is back to operating mode.

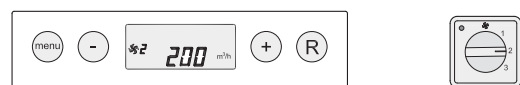

08 Maintenance

Heat exchanger and fan cleaning

Installer maintenance includes cleaning the heat exchanger and fans. Dependent on the conditions, this must be done about once every three years.

1. Switch off the appliance on the control panel [Press the 'OFF' key for 5 seconds; the appliance will be switched off through software] and switch off the power. Open the filter door.

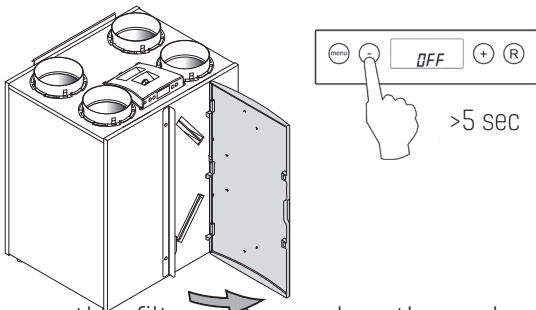

2. Remove the filters. Remember the order in which they came out.

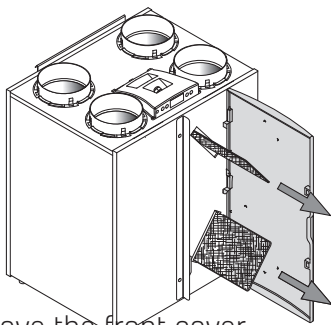

3. Remove the front cover.

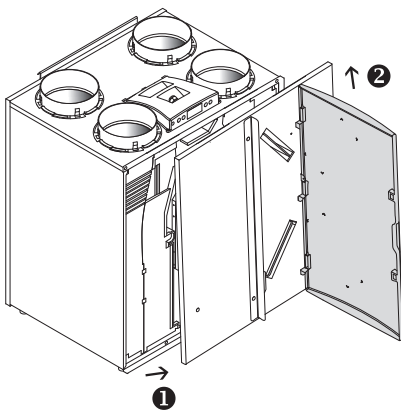

4. Remove the heat exchanger. Be careful not to damage the foam parts in the appliance.

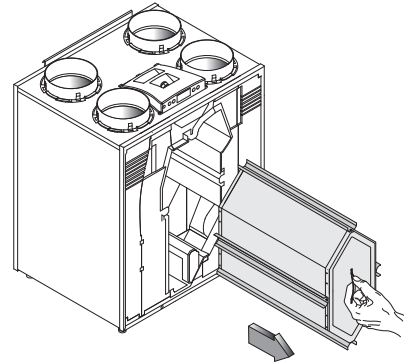

5. Rinse the exchanger with warm water (max. 55°C) and a regular detergent. Rinse the exchanger with warm water.

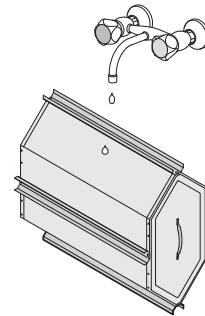

6. Take off the display cover.
Note: First disconnect the connectors on the rear of the display cover.

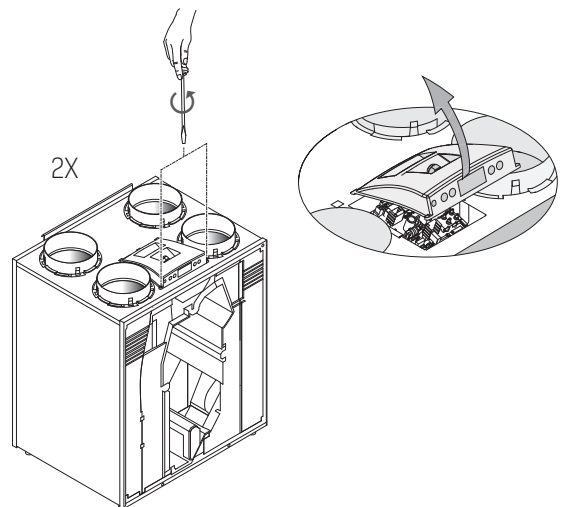

AFTER INSTALLING THIS UNIT PLEASE PASS ON TO END USER
DO NOT THROW AWAY

08 Maintenance

Heat exchanger and fan cleaning

7. Remove 4 pressure hoses and 3 connectors from the board.
8. Slide the fan assembly out of the appliance.

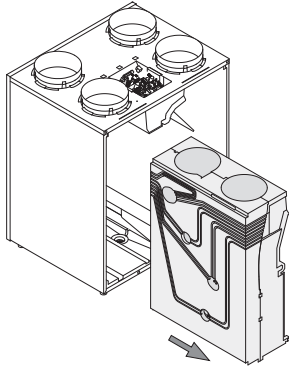

9. Place the fan assembly on a flat surface with the pressure hoses facing up. Remove the red and blue pressure hose without black mark from the pressure tubes mounted in the fan assembly. Turn over the foam assembly so the section with the pressure hoses is facing down.

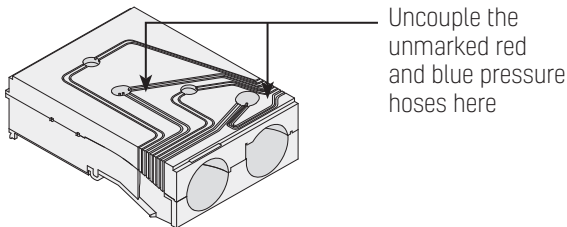

10. Now the fan assembly can carefully be split so the two fans are accessible. Make sure the fans remain in the lower fan section.

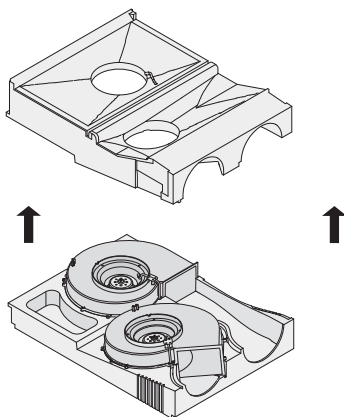

11. Clean the fans with a soft brush.
Make sure the balancing weights do not shift.

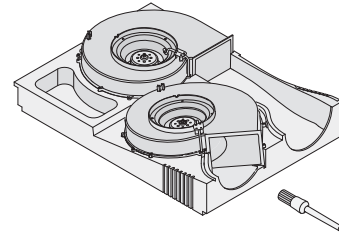

12. Replace the separated part of the fan assembly and reconnect the loose pressure hoses to the pressure tubes. **Make sure no dirt enters the pressure tubes!**
13. Place the complete fan assembly back into the appliance.
14. Reconnect the pressure hoses and the fan cables to the board. Note the marking sticker on the pressure sensor for the correct position of the pressure hoses. Refer to the sticker in the appliance for the correct position of the connectors.
15. Remount the display cover and reconnect the loose connectors on the rear of the display cover.
16. Place the heat exchanger back into the appliance.
17. Place the front cover.
18. Place the filters back into the appliance with the clean side facing the exchanger.
19. Close the filter door.
20. Switch on the power supply.
21. Switch on the appliance on the control panel [press key "-" for 5 seconds].
22. After cleaning the filter or placing a new filter, reset the filter indication by pressing the key "R" for 5 seconds.

09 Electric Connections

Wiring diagram

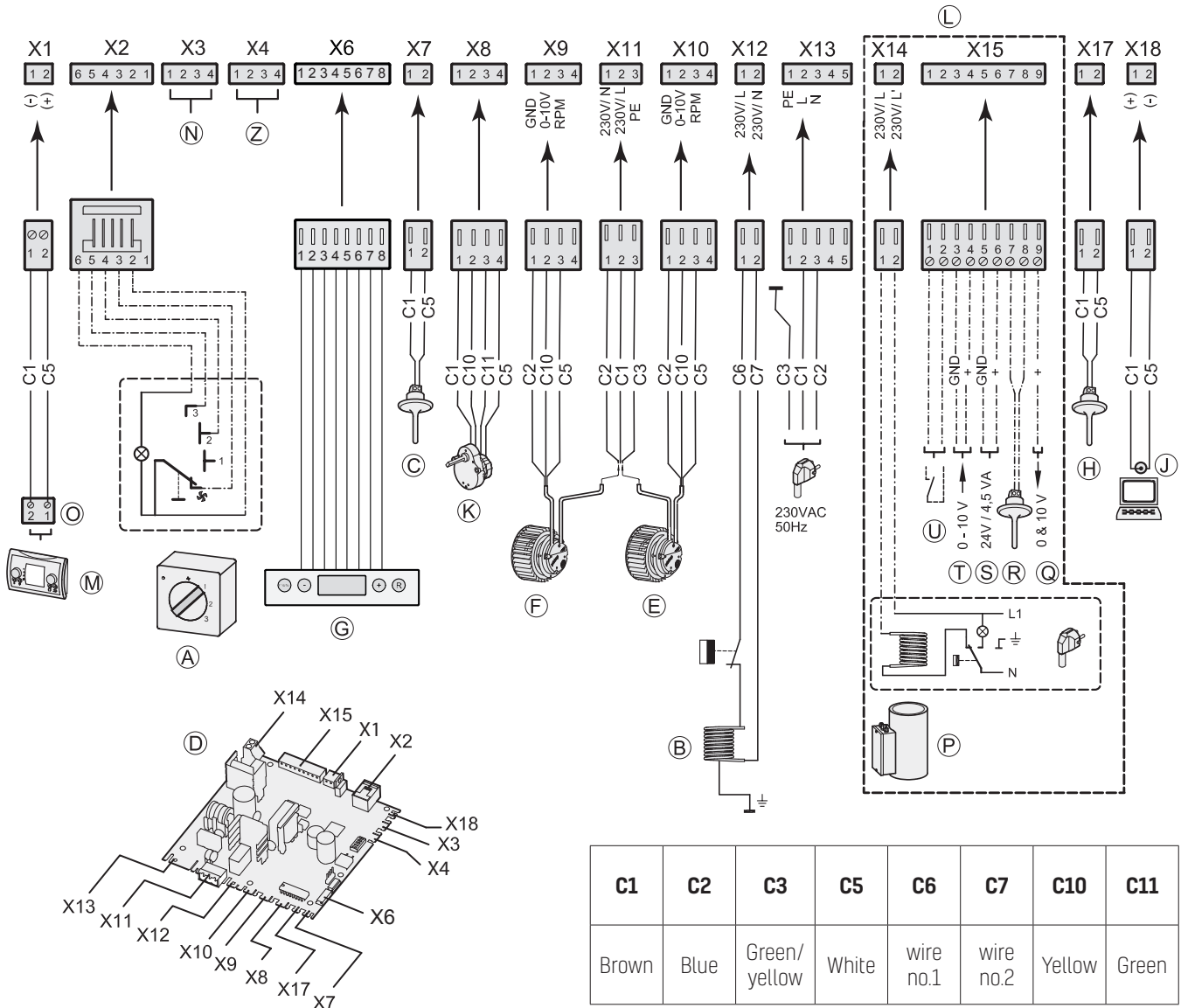

- A = Multiple switch
- B = Preheater
- C = Outdoor temperature sensor
- D = Control board
- E = Supply fan
- F = Extract fan
- G = Control panel
- H = Indoor temperature sensor
- J = Service connector

- K = Valve motor bypass
- L = Plus version
- N = Not applicable
- O = E bus connector (polarity sensitive) or OpenTherm, application depending on parameter setting 8
- P = Postheater (Plus version)
- Q = Output 0-10 V(Plus version)

- R = Sensor postheater or outdoor sensor geo heat exchanger (Plus version)
- S = 24 volt connector (Plus version)
- T = Input 0-10 V (or make contact) (Plus version)
- U = Make contact or input 0-10 V (Plus version)
- Z = RH-sensor (option)

AFTER INSTALLING THIS UNIT PLEASE PASS ON TO END USER
DO NOT THROW AWAY

10 Electric Connections Accessories

Connector X1

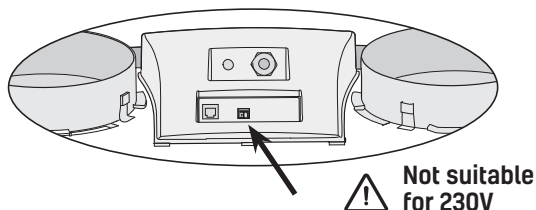

EBus or. OpenTherm connector X1
Two-pole screw connector.
Set ex factory as eBus connector; after modifying parameter 8 in the Settings menu, also suitable as OpenTherm connector (see page 35).
Only suitable for low voltage.
Note: For the eBus Application, this connector is polarity-specific.

Connector X2

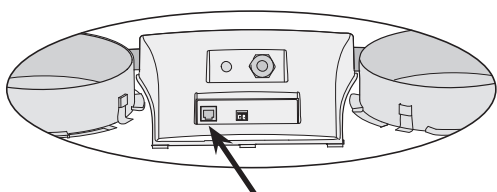

Modular connector X2 for rpm control
Modular connector type RJ-12.
Only suitable for low voltage

Connector X14 (only for Plus version)

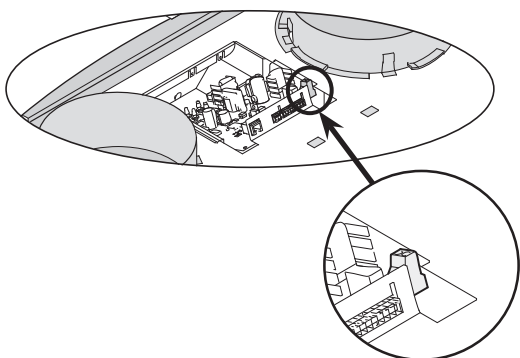

Connector X14 for connecting postheater
Two-pole screw connector (accessible after taking off display cover).
Ex factory this connector is not activated; after changing parameter 13 in the settings menu of "0" to "1" (preheater) or "2" (postheater), this connector can be used for connecting the postheater or preheater
Maximum rated power is 1000W.
Note: The postheater temperature sensor must also be connected to X15-7 and X15-8.
For the Plus version, use the additionally mounted pull relief in the display cover to feed the 230V cable to the postheater.

Connector X15 (only for Plus version)

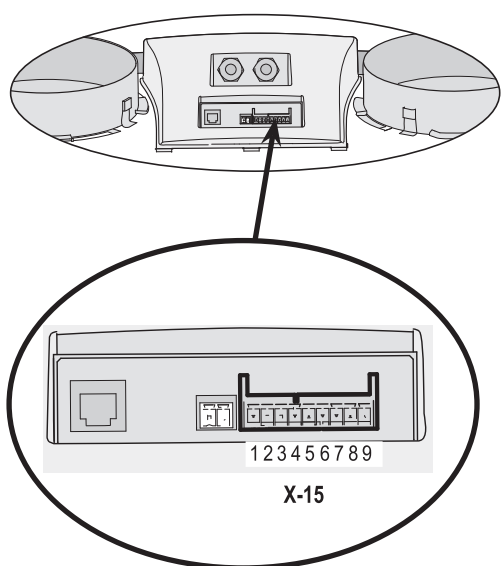

Connector X15 (9-pole) for connecting special versions

Connection	Application
1 & 2 (input 1)	Step no. 15 = 0: normally open contact (= factory setting) [see page 38]
	Step no. 15 = 1: 0 - 10V input 1; X15-1=GND & 15 - 2 = 0 - 10V [see §11.8]
	Step no. 15 = 2: normally closed contact
	Step no. 15 = 3: input 1/ bypas open 12V; bypass closed 0V
3 & 4 (input 2)	Step no. 15 = 4: input 1/ bypas open 0V; bypass closed 12V
	Step no. 21 = 0: normally open contact
5 & 6	Step no. 21 = 1: 0 - 10V input (= factory setting) [see page 39].
	Step no. 21 = 2: normally closed contact
	Step no. 21 = 3: input 2/ bypas open 12V; bypass closed 0V
	Step no. 21 = 4: input 2/ bypas open 0V; bypass closed 12V
7 & 8	Conn. 24 volt , 4.5 VA maximum [5 = ground , 6 = +]
9	Connection postheater sensor or and outdoor geo heat exchanger Control signal valve 0 or 10 V [9 = + , 5 = ground]

10 Electric Connections Accessories

Connection examples multiple switch

A multiple switch can be connected to the modular connector X2 of the units. This modular connector X2 is directly accessible at the rear of the display cover (see page 33) without having to take it off.

Multiple switch with filter indication

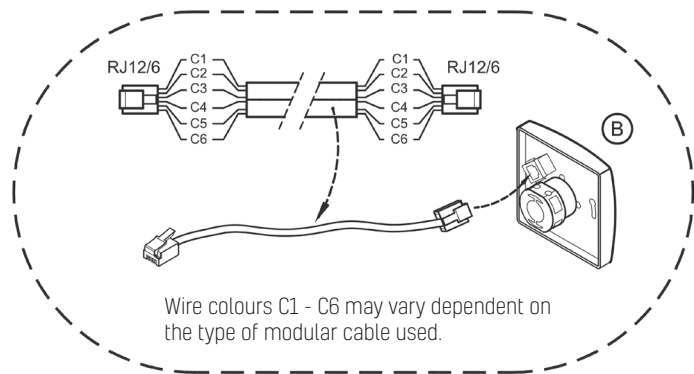
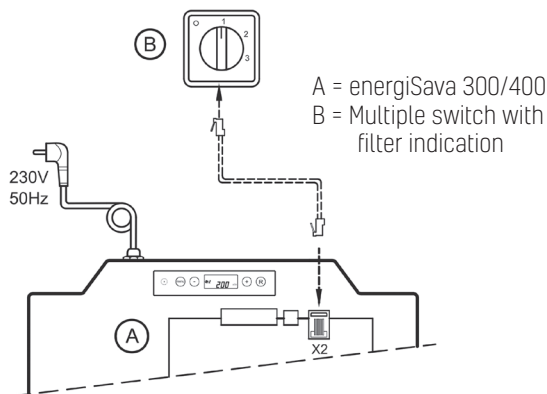

Note: For the modular cable use, the "tab" of both modular connectors must be mounted facing the mark on the modular cable.

Wireless remote control (without filter indication)

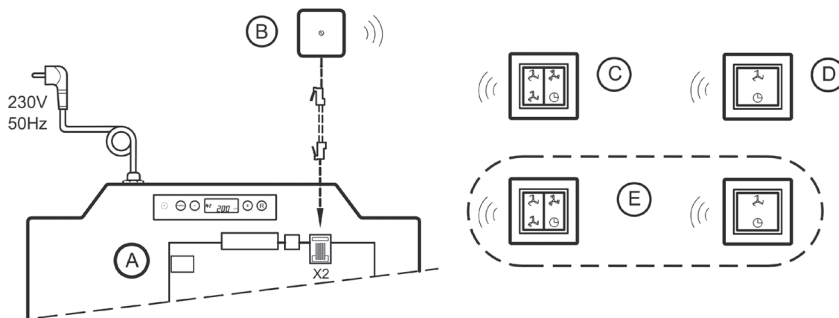

- A = energiSava 300/400
- B = Receiver for wireless remote control
- C = Transmitter with 4 settings (e.g. kitchen)
- D = Transmitter with 2 settings (e.g. bathroom)
- E = Any additional 2- or 4-settings transmitters (A maximum of 6 transmitters can be signed on to 1 receiver)

Additional multiple switch with filter indication

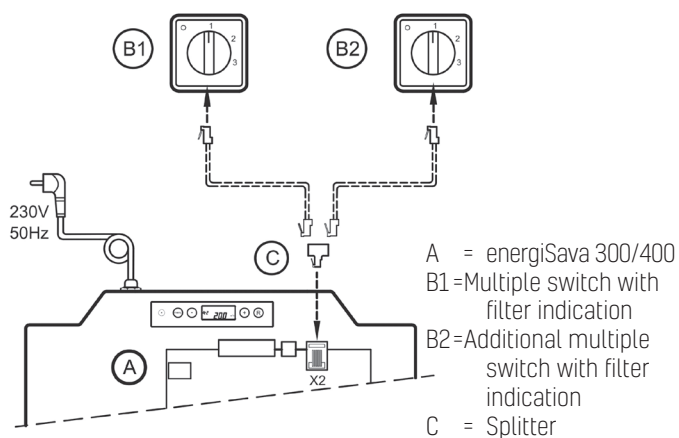

Additional multiple switch with wireless remote control

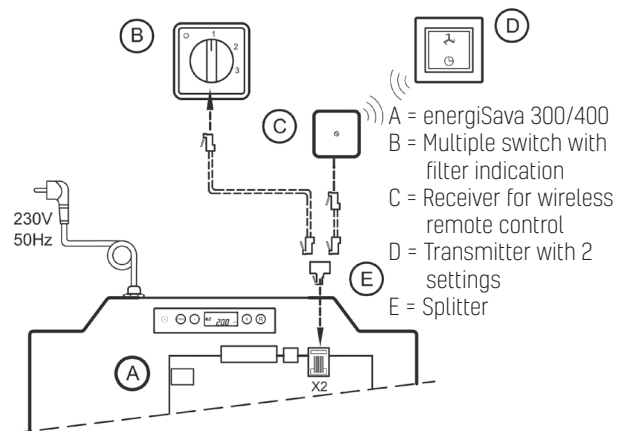

AFTER INSTALLING THIS UNIT PLEASE PASS ON TO END USER
DO NOT THROW AWAY

10 Electric Connections Accessories

Couple through eBus contact; all appliances equal air flow rate

Important:

Because of polarity sensitivity, always connect contacts X1-1 to X1-1 and contacts X1-2 to X1-2. Never connect X1-1 and X1-2.

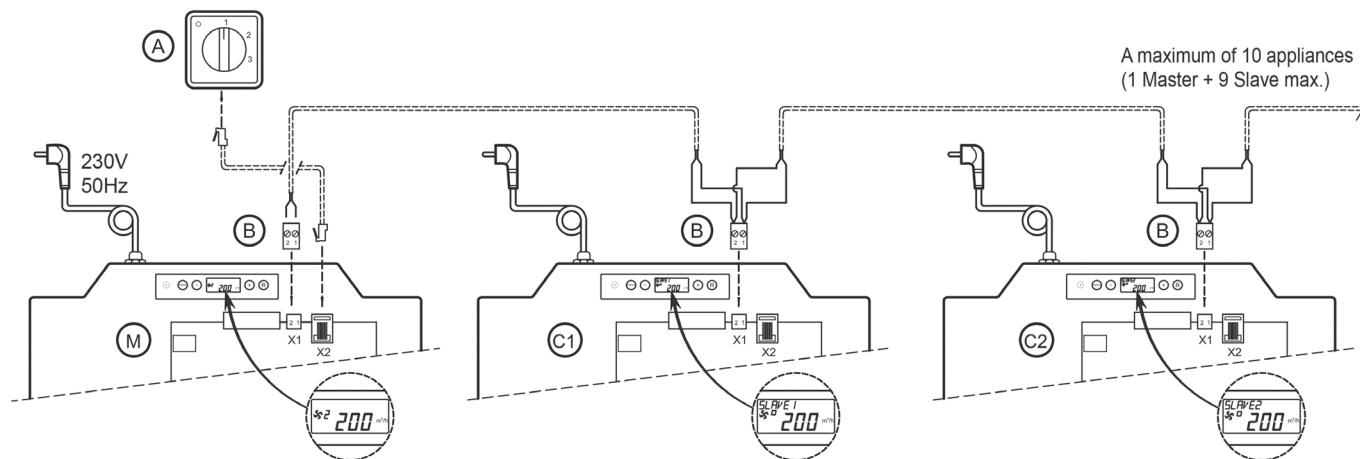

For M (Master):
Set parameter 9 to 0 [= factory setting].
Display shows ventilation mode 1, 2 or 3.

For C1 (Slave1):
Set parameter 9 to 1 [= Slave 1].
Display always shows ventilation mode.

For C2 (Slave2):
Set parameter 9 to 2 [= Slave 2].
Display always shows ventilation mode.

- A = Multiple switch
- B = 2-pole connector
- M = (Master)
- C1 t/m C*= (Slave); couple not more than 10 appliances through Ebus

All units have the same air flow rates as the units set as "Master".

Step no.	Description	Factory setting	Range
8	Communication type	eBus	0t [= Opentherm] eBus
9	eBus address	0	0 = master 1- 9 = slave 1 - 9

Connection RH (humidity)- sensor

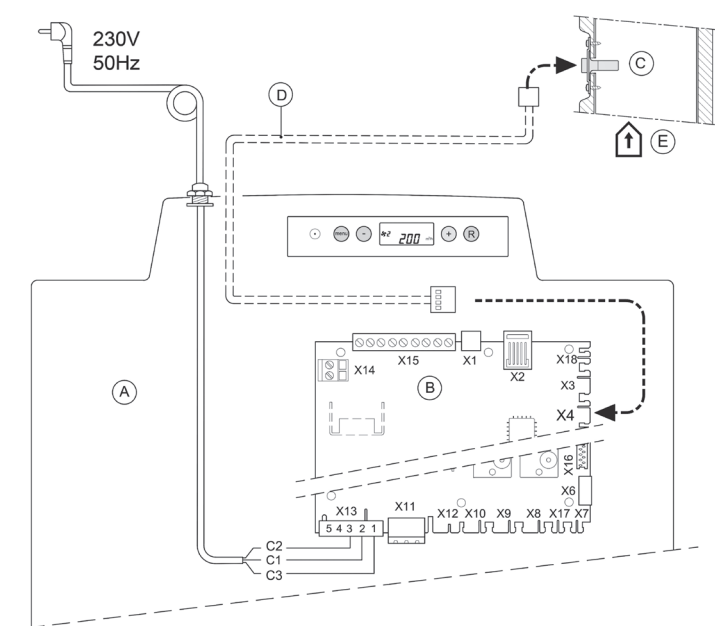

- A = energiSava 300/400
- B = Control board
- C = RH (humidity) - sensor
- D = Cable supplied with RH sensor
- E = Duct from dwelling ↑

- C1 = Brown
- C2 = Blue
- C3 = green/yellow

Step no.	Description	Factory setting	Range
30	Activating RH-sensor	OFF	OFF = not active ON = active
31	Sensitivity	0	+2most sensitive +1 0 default setting RH-sensor -1 -2least sensitive

10 Electric Connections Accessories

Wiring diagram postheater connection (Plus version only)

The electrical connections of the postheater and the extra preheater are the same; the only difference is that the postheater has an additional temperature sensor that must be wired to connector X15. Please refer to the mounting instructions that came with the heater for more extensive information regarding installation of the postheater or the extra preheater.

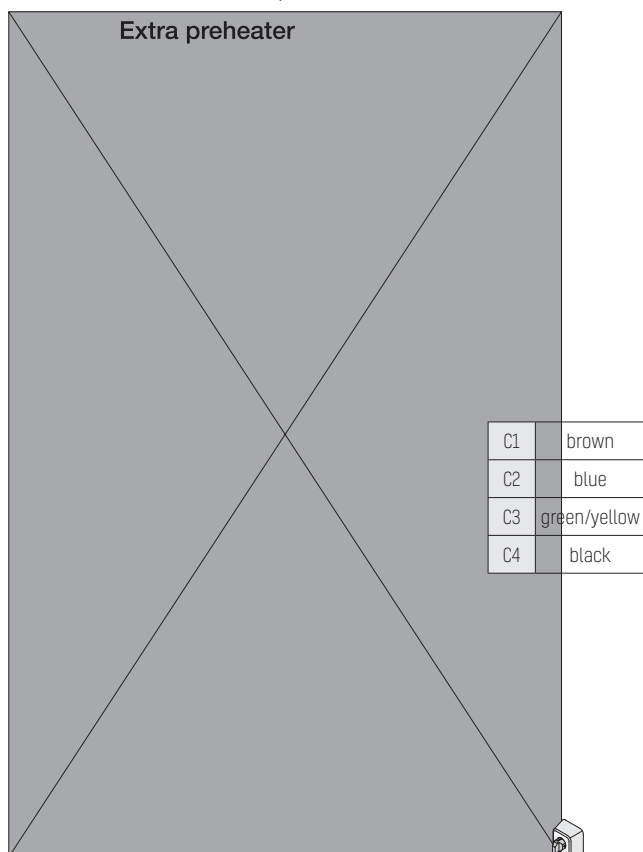

A	Plus version
B	Control board Plus version
C	Heating coil max. 1000W
D	Maximum safety with manual reset
E	LED maximum safety; lights up when activated
F	Cables to be connected by installer
G	Flow direction through the heater

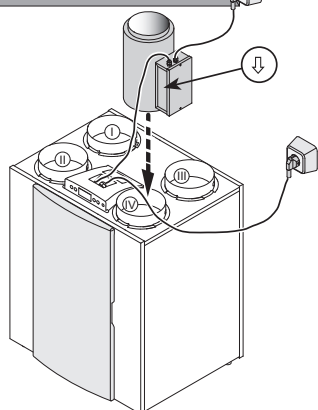

I =		To dwelling
II =		To atmosphere
III =		From dwelling
IV =		From atmosphere

Step no.	Descr.	Factory setting	Range
13	Heater	0	0 = Off 1 = Preheater 2 = Postheater

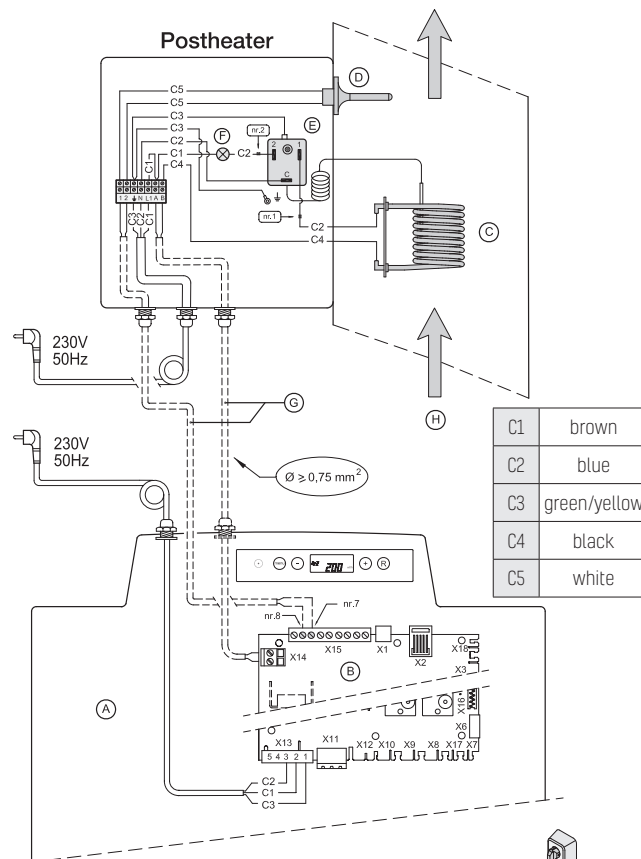

C1	brown
C2	blue
C3	green/yellow
C4	black
C5	white

A	Plus version
B	Control board Plus version
C	Heating coil max. 1000W
D	Temperature sensor
E	Maximum safety with manual reset
F	LED maximum safety; lights up when activated
G	Cables to be connected by installer
H	Flow direction through the heater

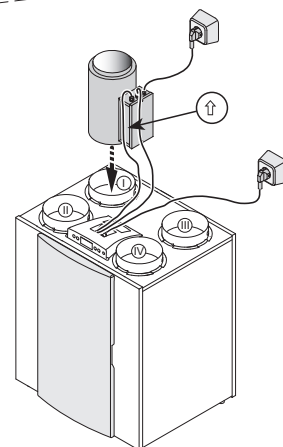

I =		To dwelling
II =		To atmosphere
III =		From dwelling
IV =		From atmosphere

Step no.	Descr.	Factory setting	Range
13	Heater	0	0 = Off 1 = Preheater 2 = Postheater
14	Temp. post heater	21°C	15°C - 30°C

AFTER INSTALLING THIS UNIT PLEASE PASS ON TO END USER
DO NOT THROW AWAY

10 Electric Connections Accessories

Connecting external switch contact (Plus version only)

An external switch contact (e.g. switch or relay contact) can be connected to the Plus version units. This external switch contact can be connected to connections no. 1 and no. 2 of 9-pole connector X15; this 9-pole connector is directly accessible at the rear of the top without having to dismount the display cover (see also page 33). If a second input is required as external switch contact, if necessary connections

no. 3 and no. 4 of the 9-pole connector X15, which as standard are preprogrammed as 0-10 volt input, can be reprogrammed as second input switch contact. Changing parameter 21 from "0" to "1" will turn this 0-10 V input into an input make contact. When using two switch inputs, switch contact 1 [X15-1 & X15-2] always takes priority over switch contact 2 [X15-3 & X15-4].

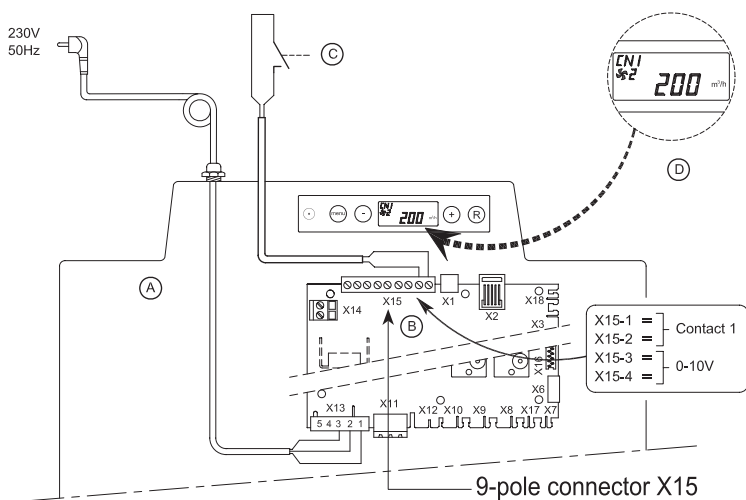

Modifying parameter 18 enables, when closing the input external switch contact 1 X15-1 and X15-2, five different situations for the extract fan to be set; dependent on the setting of parameters 19 and 20, the supply and extract fans can run at various flow rates (highest flow rate is shown on the display).

A = Plus version

B = Plus version control board

C = Contact connected to switch input 1; for instance a switch or a relay contact

D = Display Plus version [text "CN1" appears when contact C is closed.]

Setting Parameter 18	Function conditions	Situation supply fan extract fan	Setting parameters 19 & 20	Action supply or extract fan when closing contact inputs X15-1 & X15-2
0 (factory setting)	Contact input 1 15-1 & X15-2 closed	No action possible because contact input 1 has not been activated yet (parameter 18 is still at 0)		
1	Contact input 1 15-1 & X15-2 closed	Action dependent on setting supply fan (parameter 19) and extract fan (parameter 20)	0	Fan switches off
2	Contact input 1 15-1 & X15-2 closed Satisfies bypass conditions for valve open ¹		1	Fan minimum flow rate (50m³/h)
3	Contact input 1 15-1 & X15-2 closed	The bypass valve opens; automatic bypass control in units is overruled; action fans dependent on parameters 19 & 20	2	Fan to flow rate mode 1
			3	Fan to flow rate mode 2
4	Contact input 1 15-1 & X15-2 closed		4	Fan to flow rate mode 3
			5	Fan to flow rate multiple switch
			6	Fan to maximum flow rate
			7	No fan activation

1) Bypass conditions opening valve:

- outdoor temperature is higher than 10°C.
- temperature from atmosphere is at least lower than temperature from dwelling.
- temperature from dwelling is higher than the preset bypass temperature (parameter 5).

When connections X15-3 and X15-4 are programmed as switch input 2, parameters 24, 25 and 26 can be used to set the various situations the same as for contact input 1. When closing contact input 2, the display shows the text "CN2".

10 Electric Connections Accessories

Connection to 0-10V input (Plus version only)

The Plus versions can be equipped with an external provision with 0-10 volt control] (e.g. humidity sensor or CO₂ sensor). This external provision can be connected to pins no. 3 and no. 4 of 9-pole connector X15; this 9-pole connector is directly accessible at the rear of the top without having to dismount the display cover (see also page 33).

Connections X15-3 and X15-4 are set as standard as 0 - 10 V input; it is activated as standard.

Parameter 21 is set "1" ex factory. When the connected provision is active, the display shows the message V2. The minimum and maximum voltage for connected provisions can be set between 0 and 10 volt with parameter 22 (minimum voltage) and 23 (maximum voltage).

The minimum voltage for parameter 22 cannot be set higher than the voltage set for parameter 23; the maximum voltage for parameter 23 cannot be set lower than the voltage set for parameter 22.

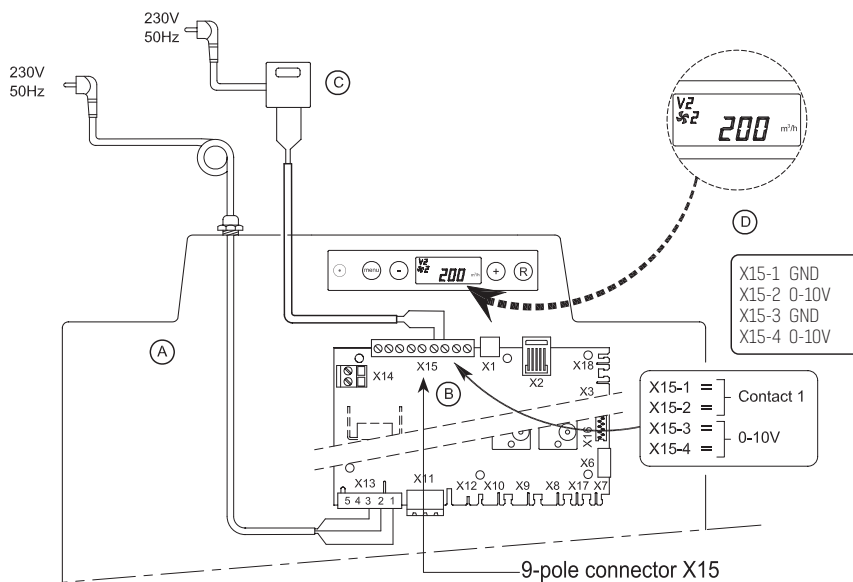

A = Plus version

B = Plus version control board

C = Provision connected to 0-10 V input; for instance a humidity sensor or a CO₂ sensor.

Connected provision has its own power supply.

D = Display Plus version (text "V2" appears when the provision is active on input 2.)

If a second 0-10V input is required, if necessary connections no. 1 and no. 2 of the 9-pole connector X15, standard preprogrammed as switch contact, can be reprogrammed to a second input 0-10V. Modifying parameter 15 from "0" to "1" makes this input into a proportional 0-10 V input. When using two 0 - 10V inputs, the 0 - 10V input with the highest flow rate always takes precedence.

Ex factory activated 0 - 10 V input (when active, the display shows the text "V2")				
Connection	Parameter	Description	Adjusting range	Factory setting
X15-3 & X15-4	21	do/ do not activate 0 - 10 V input	1 = Switched on 0 = Switched off	1
	22	minimum voltage 0 - 10 volt	0.0 volt - 10.0 volt	0.0 volt
	23	maximum voltage 0 - 10 volt	0.0 volt - 10.0 volt	10.0 volt

If connection X15-1 and X15-2 are programmed as second 0-10V input, parameters 15, 16 and 17 can be used to modify the various situations the same as for the standard 0-10V input. When the provision is active on the optional second 0-10V input, the display shows the text "V1".

AFTER INSTALLING THIS UNIT PLEASE PASS ON TO END USER
DO NOT THROW AWAY

10 Servicing

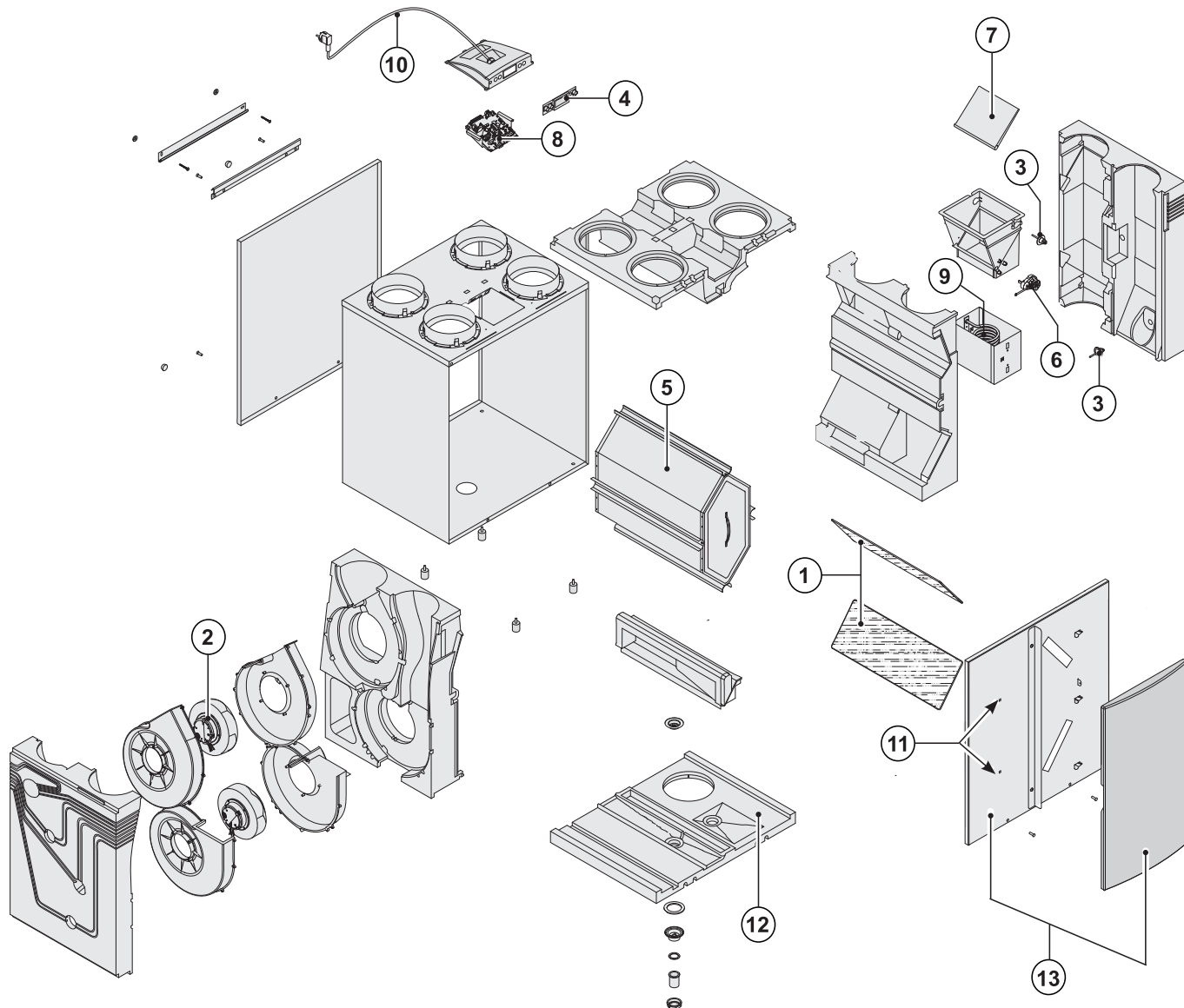

10 Servicing

1	Filter kit 2 x G3 filter [standard version]	Please contact EnviroVent for order codes
2	Fan 300/400 [1 pcs]	
3	Temperature sensor NTC 10K[1 pcs]	
4	Control panel UBP-01	
5	Heat exchanger	
6	Motor bypass valve	
7	Bypass valve	
8	Control board [Plus version]	
9	Heating coil 1000W preheater	
10	Cable with power plug 230V with display cover*	
11	Door closing [2 pcs]	
12	EPS bottom plate incl. condensate outlet connection	
13	Filter door [left and right]	

















When ordering parts, [see exploded view], please state the type of the heat recovery appliance, the serial number, the year of production and the name of the part:

N. B.:

Appliance type, serial number and year of production are stated on the identification plate on the top of the appliance.









* When replacing a main cable, always order a replacement mains cable from EnviroVent to avoid danger. A damaged mains should only be replaced by a qualified person.

11 Setting Values

STEP NO.	DESCRIPTION	FACTORY SETTING	ADJUSTING RANGE	STEP	DISPLAY TEXT + SYMBOLS
1	Air flow rate mode Exc. 300 : mode 	50 m³/h	0 m³/h of 50 m³/h		
	Air flow rate mode Exc. 400 : mode 	50 m³/h	0 m³/h of 50 m³/h		
2	Air flow rate mode Exc. 300 : mode 1	100 m³/h	50 m³/h - 300 m³/h	5 m³/h	 1
	Air flow rate mode Exc. 400 : mode 1	100 m³/h	50 m³/h - 400 m³/h		
3	Air flow rate mode Exc. 300 : mode 2	150 m³/h	50 m³/h - 300 m³/h	5 m³/h	 2
	Air flow rate mode Exc. 400 : mode 2	200 m³/h	50 m³/h - 400 m³/h		
4	Air flow rate mode Exc. 300 : mode 3	225 m³/h	50 m³/h - 300 m³/h	5 m³/h	 3
	Air flow rate mode Exc. 400 : mode 3	300 m³/h	50 m³/h - 400 m³/h		
5	Bypass temperature	22,0 °C	15,0 °C - 35,0 °C	0,5 °C	BYPASS 
6	Bypass hysteresis	2,0 °C	0,0 °C - 5,0 °C	0,5 °C	BY HYS 
7	Operation bypass valve	0	0 [= Automatic] 1 [= Bypass valve closed] 2 [= Bypass valve open]		BYPASS 
8	Communication	eBUS	0t [= Opentherm] eBUS		OT/BUS
9	Bus address	0	0 - 9 [0 = Master]		BUSADR
10	Central heating + heat recovery	OFF	OFF [= Central heating+heat rec. off] ON [= Central heating+heat rec. on]		CV+WTW
11	Imbalance permissible	ON	OFF [= flow rate sup. equals extract] ON [= imbalance permissible]		 
12	Fixed imbalance	0 m³/h	-100 m³/h t/m 100 m³/h		 
STEP NO.	DESCRIPTION	FACTORY SETTING excl. Plus	ADJUSTING RANGE	STEP	DISPLAY TEXT + SYMBOLS
13	Heater	0	0 [= no additional heater] 1 [= additional preheater] 2 [= postheater]		HEATER 
14	Temperature postheater	21,0 °C	15,0 °C t/m 30,0 °C	0,5 °C	HEATER 
15	Selection input 1	OFF	0 [= normally open contact] 1 [= 0 - 10V input] 2 [= normally closed contact] 3 [= input 1/ bypass open 12V; bypass closed 0V] 4 [= input 1/ bypass open 0V; bypass closed 12V]		V1
16	Minimum voltage input 1	0,0 V	0 Volt - 10 Volt	0,5 V	V1 MIN
17	Maximum voltage input 1	10,0 V	0 Volt - 10 Volt	0,5 V	V1 MAX
18	Conditions switching input 1	0	0 [off] 1 [on] 2 [= On if conditions bypass open satisfied] 3 [= Bypass control] 4 [= Bedroom valve]		CN1
19	Supply fan mode switching input 1	5	0 [= Input fan off] 1 [= Absolute min. flow rate 50m³/h] 2 [= Flow rate mode 1] 3 [= Flow rate mode 2] 4 [= Flow rate mode 3] 5 [= Multiple switch] 6 [= Maximum flow rate] 7 [= no fan activation]		CN1  

SHOULD YOU ENCOUNTER ANY PROBLEMS INSTALLING THIS UNIT CALL
0345 27 27 810

11 Setting Values

STEP NO.	DESCRIPTION	FACTORY SETTING excl. Plus	ADJUSTING RANGE	STEP	DISPLAY TEXT + SYMBOLS
20	Extract fan mode switching input 1	5	0 [= Extract fan off] 1 [= Absolute min. flow rate 50m ³ /h] 2 [= Flow rate mode 1] 3 [= Flow rate mode 2] 4 [= Flow rate mode 3] 5 [= Multiple switch] 6 [= Maximum flow rate] 7 [= no fan activation]		CN1  
21	Selection input 2	1	0 [= normally open contact] 1 [= 0 - 10V input] 2 [= normally closed contact] 3 [= input 2/ bypass open 12V; bypass closed 0V] 4 [= input 2/ bypass open 0V; bypass closed 12V]		V2
22	Minimum voltage input 2	0,0 V	0,0 Volt - 10,0 Volt	0,5 V	V2 MIN
23	Maximum voltage input 2	10,0 V	0,0 Volt- 10,0 Volt	0,5 V	V2 MAX
24	Conditions switching input 2	0	0 [off] 1 [on] 2 [= On if conditions bypass open satisfied] 3 [= Bypass control] 4 [= Bedroom valve]		CN2
25	Supply fan mode switching input 2	5	0 [= Input fan off] 1 [= Absolute min. flow rate 50m ³ /h] 2 [= Flow rate mode 1] 3 [= Flow rate mode 2] 4 [= Flow rate mode 3] 5 [= Multiple switch] 6 [= Maximum flow rate] 7 [= No input fan activation]		CN2  
26	Extract fan mode switching input 2	5	0 [= Extract fan off] 1 [= Absolute min. flow rate 50m ³ /h] 2 [= Flow rate mode 1] 3 [= Flow rate mode 2] 4 [= Flow rate mode 3] 5 [= Multiple switch] 6 [= Maximum flow rate] 7 [= No extract fan activation]		CN2  
27	Geo heat exchanger	OFF	OFF [= Valve control geo heat exchanger off] ON [= Valve control geo heat exchanger on]		EWT
28	Minimum temperature geo heat exchanger (Below this temperature the valve opens)	5,0 °C	0,0 °C - 10,0 °C	0,5 °C	EWT T- 
29	Maximum temperature geo heat exchanger (Above this temperature the valve opens)	25,0 °C	15,0 °C - 40,0 °C	0,5 °C	EWT T+ 
STEP NO.	DESCRIPTION	FACTORY SETTING	ADJUSTING RANGE	STEP	DISPLAY TEXT + SYMBOLS
30	RH-sensor	OFF	OFF [= RH-sensor not active] ON [= RH-sensor active]		
31	Sensitivity RH-sensor	0	+2 most sensitive +1 0 default setting RH-sensor -1 -2 least sensitive		

AFTER INSTALLING THIS UNIT PLEASE PASS ONTO END USER
DO NOT THROW AWAY

11 Setting Values

STEP NO.	DESCRIPTION	FACTORY SETTING Plus	ADJUSTING RANGE	STEP
35	Switching on and off eBUS CO ₂ sensor	OFF	ON - OFF	
36	Min.PPM eBUS CO ₂ -sensor 1	400	400 - 2000	25
37	Max.PPM eBUS CO ₂ -sensor 1	1200		
38	Min.PPM eBUS CO ₂ -sensor 2	400		
39	Max.PPM eBUS CO ₂ -sensor 2	1200		
40	Min.PPM eBUS CO ₂ -sensor 3	400		
41	Max.PPM eBUS CO ₂ -sensor 3	1200		
42	Min.PPM eBUS CO ₂ -sensor 4	400		
43	Max.PPM eBUS CO ₂ -sensor 4	1200		
44	Flow correction	100%	90% - 110%	
45	Default position switch	1	0 - 1	

12 ErP

Product data sheet conform Ecodesign (EU), nr. 1254/2014 (Annex IV)					
Supplier:		EnviroVent			
Model:		energiSava 300			
Climate zone	Type of control	SEC-Value in kWh/m ² /a	Energy class [SEC]	The annual electricity consumption (AEC) in kWh	The annual heating saved (AHS) in kWh
Average	Manual	-37,52	A	308	4454
	Clock	-38,38	A	282	4477
	1 Sensor (RH/CO ₂ /VOC)	-40,01	A	235	4521
	2 or more Sensors (RH/CO ₂ /VOC)	-42,88	A+	156	4611
Cold	Manual	-74,75	A+	845	8714
	Clock	-75,82	A+	819	8758
	1 Sensor (RH/CO ₂ /VOC)	-77,88	A+	772	8845
	2 or more Sensors (RH/CO ₂ /VOC)	-81,60	A+	693	9019
Warm	Manual	-13,57	F	263	2014
	Clock	-14,31	E	237	2024
	1 Sensor (RH/CO ₂ /VOC)	-15,69	E	190	2045
	2 or more Sensors (RH/CO ₂ /VOC)	-18,07	E	111	2085
Type of ventilation unit:		Ventilation unit with heat recovery			
Fan:		Variable speed EC fan			
Type of heat exchanger:		Recuperative plastic cross-counterflow heat exchanger			
Thermal efficiency:		86%			
Maximum flow rate:		300 m ³ /h			
Electric power input:		92 W			
Sound power level L _{wa} :		44 dB(A)			
Reference flow rate :		210 m ³ /h			
Reference pressure difference:		50Pa			
Specific Power Input (SEL):		0,21 W/m ³ /h			
Control factor:		1,0 in combination with manual switch			
		0,95 in combination with clock			
		0,85 in combination with 1 sensor			
		0,65 in combination with 2 or more sensors			
Leakage*:	Internal	0,8%			
	External	2,1%			
Filter warning:		On the display of the ventilation unit / Manual switch / clock control. Attention! For optimal energy efficiency and a proper operation a regular filter inspection, cleaning or replacement is necessary.			
Internet address for Assembly instructions:		www.envirovent.com			
Bypass:		Yes; 100% Bypass			

*Measurements executed by TNO according to the EN 13141-7 standard (TNO-report TNO 2013 M10230, February 2013)

AFTER INSTALLING THIS UNIT PLEASE PASS ON TO END USER
DO NOT THROW AWAY

12 ErP

Product data sheet conform Ecodesign (EU), nr. 1254/2014 (Annex IV)					
Supplier:		EnviroVent			
Model:		energiSava 400			
Climate zone	Type of control	SEC-Value in kWh/m ² /a	Energy class [SEC]	The annual electricity consumption (AEC) in kWh	The annual heating saved (AHS) in kWh
Average	Manual	-36,26	A	346	4423
	Clock	-37,23	A	316	4447
	1 Sensor (RH/CO ₂ /VOC)	-39,06	A	262	4494
	2 or more Sensors (RH/CO ₂ /VOC)	-42,27	A+	172	4590
Cold	Manual	-73,18	A+	883	8652
	Clock	-74,38	A+	853	8699
	1 Sensor (RH/CO ₂ /VOC)	-76,67	A+	799	8792
	2 or more Sensors (RH/CO ₂ /VOC)	-80,79	A+	709	8979
Warm	Manual	-12,48	F	301	2000
	Clock	-13,32	E	271	2011
	1 Sensor (RH/CO ₂ /VOC)	-14,89	E	217	2032
	2 or more Sensors (RH/CO ₂ /VOC)	-17,58	E	127	2075
Type of ventilation unit:		Ventilation unit with heat recovery			
Fan:		Variable speed EC fan			
Type of heat exchanger:		Recuperative plastic cross-counterflow heat exchanger			
Thermal efficiency:		85%			
Maximum flow rate:		400 m ³ /h			
Electric power input:		142 W			
Sound power level L _{wa} :		48 dB(A)			
Reference flow rate :		280 m ³ /h			
Reference pressure difference:		50Pa			
Specific Power Input (SEL):		0,24 W/m ³ /h			
Control factor:		1,0 in combination with manual switch			
		0,95 in combination with clock			
		0,85 in combination with 1 sensor			
		0,65 in combination with 2 or more sensors			
Leakage*:	Internal	0,4%			
	External	1,3%			
Filter warning:		On the display of the ventilation unit / Manual switch / clock control. Attention! For optimal energy efficiency and a proper operation a regular filter inspection, cleaning or replacement is necessary.			
Internet address for Assembly instructions:		www.envirovent.com			
Bypass:		Yes; 100% Bypass			

*Measurements executed by TNO according to the EN 13141-7 standard [TNO-report TNO 2013 M10230, February 2013]

13 Warranty

We appreciate you choosing this quality EnviroVent product, which is designed and manufactured in Harrogate, North Yorkshire. We are confident that you will be delighted with the performance of the system and the resulting improvement in air quality in your home after it has been installed.

The EnviroVent EnergiSava 300 and 400 units are covered by a parts only 2-year warranty. Please note that conditions and exclusions apply to the warranty which can be found at www.envirovent.com/warranty

Your unit serial number

What should I do if I have a problem?

If you encounter any problems with your unit, please fee free to call us on **01423 810 810**.



Delivering innovative and sustainable
ventilation solutions worldwide



Please read carefully to ensure simple installation and a long trouble free life for the user.

AFTER INSTALLING THIS FAN PLEASE PASS ONTO END USER - **DO NOT THROW AWAY**

EnviroVent Ltd
Harrogate West Business Park
Unit 1 Bardner Bank, Killinghall
Harrogate
HG3 2SP
01423 810 810
info@envirovent.com
www.envirovent.com

E&OE | MKT ENV301-V6-02.12.25

Due to our policy of continuous innovation and improvement EnviroVent reserves the right to alter products specification and appearance without notice.

615248-A,
manual energiSava 300/400