

AFTER INSTALLATION THE END USER SHOULD
KEEP THIS GUIDE FOR FUTURE REFERENCE
DO NOT THROW AWAY

damppro

[DP-EVL-H AND DP-EVL-H-W]
VENTILATION UNIT INSTALLATION GUIDE

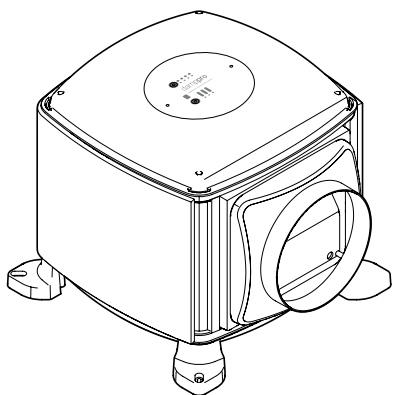

Safety

Read and understand these instructions before beginning installation. The unit should be installed by a competent person.

Location

Check there is space for the unit in your chosen location. The unit must not affect the operation of open-flue appliances. Consult local regulations or a qualified gas engineer.

The open sides of the diffuser must face a minimum 1m unobstructed path away from any smoke detectors. If the diffuser cannot be repositioned, up to two sides can be closed using the plastic blanking plates. In this configuration the open sides must face a minimum 1.5m unobstructed path away from any smoke detectors. In properties with a floor above 4.5m fire diffusers must be fitted a minimum of 1m away from the smoke detectors instead of the included plastic diffusers.

Partition walls between buildings must be complete with any breaks filled.

In properties with a floor more than 4.5m above ground level the unit must be wired into a smoke alarm (see page 12 for wiring information)

The appliance is considered suitable for use in countries with a warm damp equable climate, but may also be used in other countries.

Wiring Regulations

All wiring must comply with Building Regulations and the current IET Wiring Regulations [BS7671 in the UK] or equivalent standards for other countries. The final installation should be examined and tested by a qualified electrician.

This product is not suitable for use with a Type AC RCD 

Electrical Connection

The unit must be earthed and a suitable isolator with a minimum contact separation of 3.0mm must be used to provide insulation for the unit. The unit must be able to be disconnected from the mains supply after installation. When wiring the unit, the included unswitched fuse spur should be incorporated in the fixed wiring.

The power supply cable running into the unit must remain the supplied flexible cable (not a solid core lighting cable). If the power supply cable becomes damaged, it must be replaced by EnviroVent, an authorised service agent for your region/country, or a similarly qualified person in order to avoid a hazard. Do not remove or tamper with any electronic components inside the product.

Users

The unit is not intended for use by persons (including children) with reduced physical, sensory or mental capabilities or lack of experience and knowledge, unless they have been given supervision and usage instruction by a person responsible for their safety. Children should be supervised to ensure they do not play with the unit. Cleaning and user maintenance must not be performed by children.

Diagrams

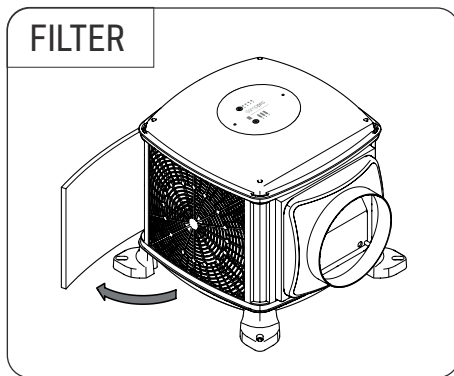
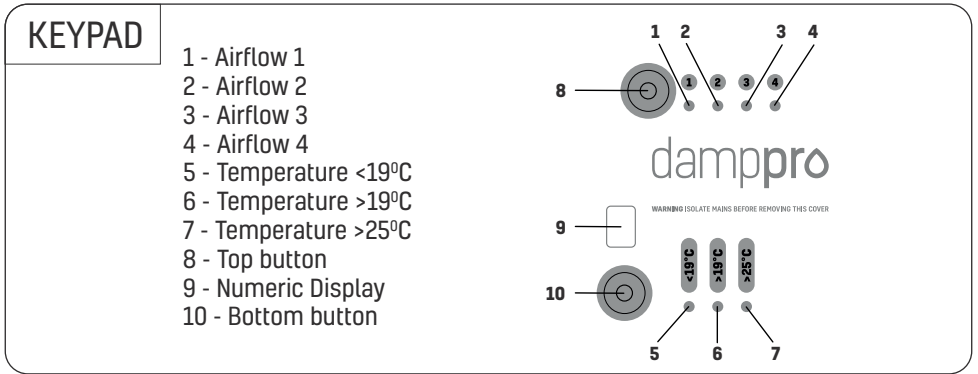
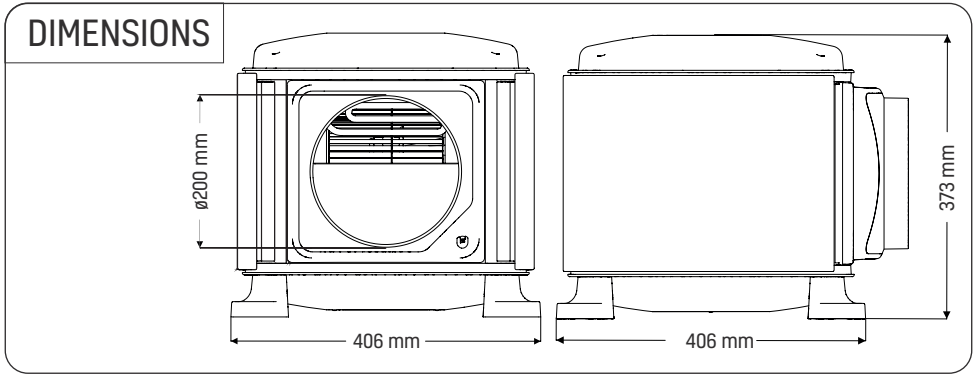

AFTER INSTALLATION THE END USER SHOULD
KEEP THIS GUIDE FOR FUTURE REFERENCE

**DO NOT
THROW AWAY**

WIRING

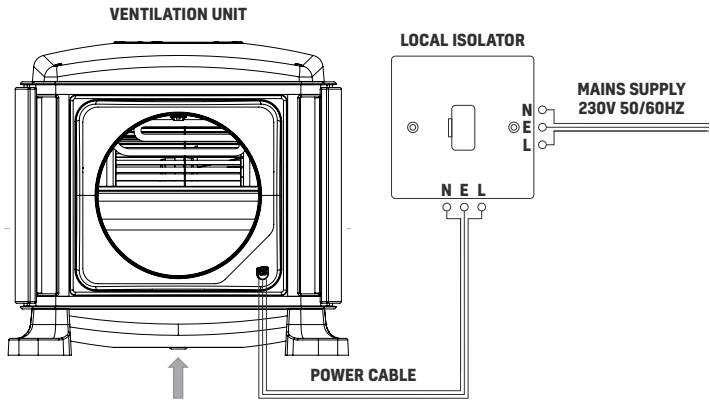

TO CONNECT OPTIONAL HEATER ENABLE CABLE SEE STEP 1 TO 4

The local isolator must be connected to the mains as part of the fixed wiring. Connect the N, L and E cores of the power cable to the matching terminals on the local isolator.

1

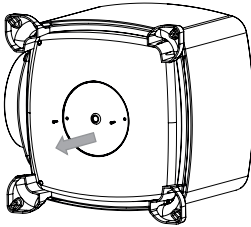

Remove base cap (two screws)

2

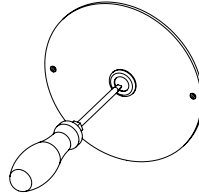

Make small hole in grommet and thread 2 core cable through

3

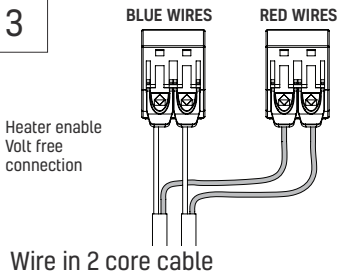

Wire in 2 core cable

4

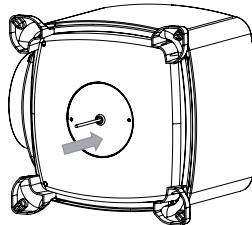

Replace base cap (two screws)

Box contents

- 1x Ventilation unit
- 1x 200mm diffuser (+ 2x blanking plates)
- 1x Instruction guide
- 1x Diffuser mounting template
- 1x Flexible duct (1m x 200mm dia.)
- 1x Unswitched fuse spur
- 1x Remote control (With DP-EVL-H-W unit only)
- 8x Foam pads
- 4x Washers
- 4x Screws 10g x 3"
- 4x Screws 10g x 1.5"
- 4x Screws 8g x 1.5"
- 4x Screws 8g x 1"
- 4x Plasterboard plugs
- 1x Roll of fixing tape

Pre - Installation Checklist

- Does the unit fit through the loft hatch?
- Check there are no obstructions in the hallway or landing where the diffuser is to be fitted and in the loft space above.
- Ensure the loft has adequate cross-flow ventilation to provide a supply of fresh air to the unit.
- Check that all partition walls are intact. Seek building advice if any are missing or broken.
- Check for flued appliances drawing air from the loft, the user should be made aware of any of these.
- Check that any flue passing through the loft is undamaged. Seek building advice if any are damaged or broken.
- Repair any ceiling gaps which allow air leakage into the loft.
- Ensure any loft water storage tanks are covered and sealed.

About the ventilation unit

The damppro loft unit is a Positive Input Ventilation (PIV) unit which creates healthy living environments by supplying filtered air into a property at a continuous rate through a ceiling mounted diffuser. The diffuser is normally installed in a hallway or landing area.

The units have been developed to improve indoor air quality and reduce condensation and mould problems.

In conditions between 19°C - 25°C the units will increase air flow rate by 10%. In hot conditions above 25°C the units will temporarily switch off to avoid bringing hot air into the property from the loft space.

Installation

1. Place a dust sheet below the required ceiling diffuser position and check the ceiling below and loft space above are unobstructed.
2. Mark a 222mm diffuser hole using the template.
3. Wearing a dust mask and eye protection, cut out the hole.

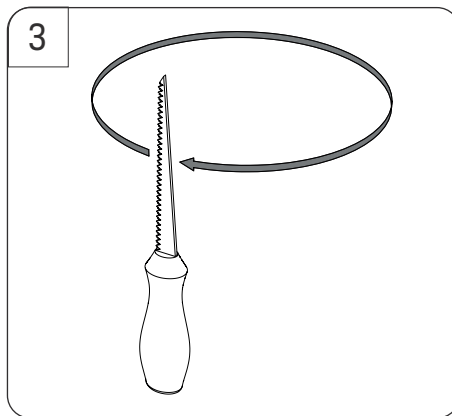
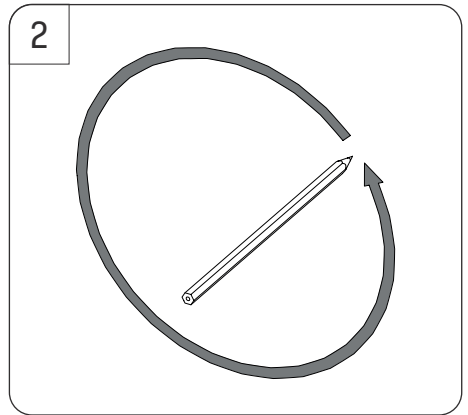
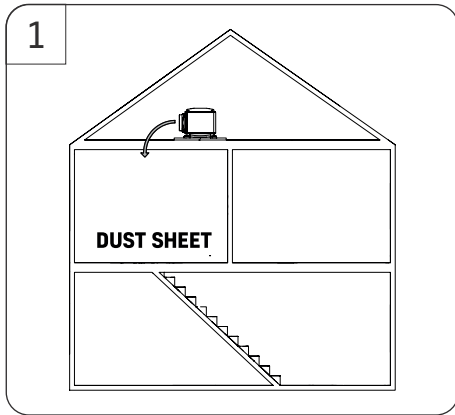

4. a) Screw the feet of the unit onto two 25mm x 50mm wood battens using the **four 10g x 1.5" screws**. (Battens not supplied).
4. b) Position the unit with anti-vibration pads and washers onto the loft ceiling joists as in the diagram.
4. c) Screw the unit to the ceiling joists using the **four 10g x 3" screws**.
- 4.d) If the loft insulation sits above the joists and impedes the unit, create a raised wooden platform to mount onto.

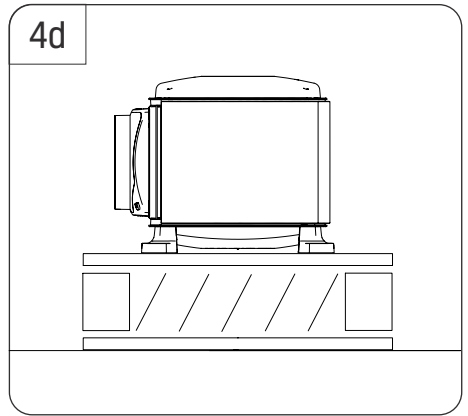
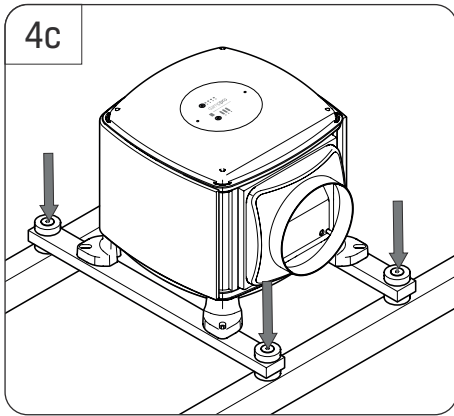
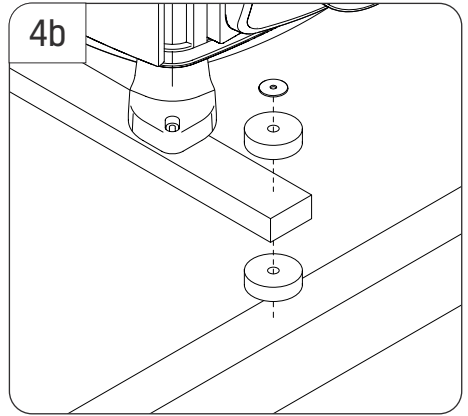
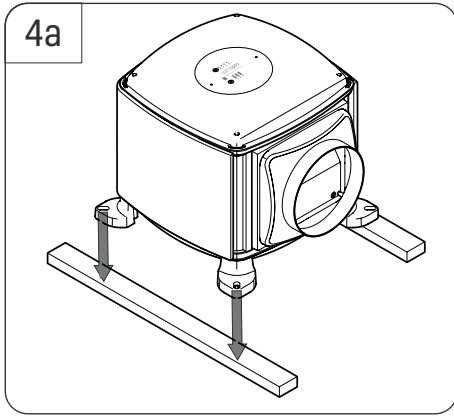

5. Insert the diffuser spigot into the ceiling hole so that the diffuser outlets face towards the walls then mark the four fixing holes.
6. Attach the duct to the spigot of the diffuser and seal the connection using the tape supplied.
7. Insert the diffuser spigot into the hole then fix it in place.
Use the four plasterboard plugs and four 8g x 1.5".
 Then clip the diffuser cover into the diffuser spigot.
8. Attach the flexible duct to the spigot on the unit and ensure it is pulled taut. Seal the connection tightly using the tape supplied. Cut the duct to length if required.

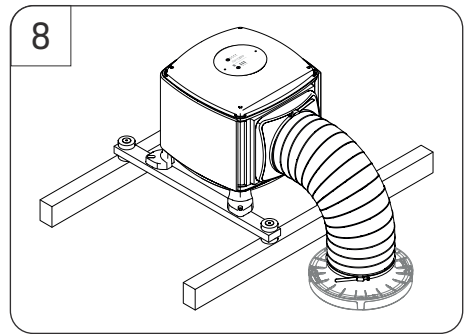
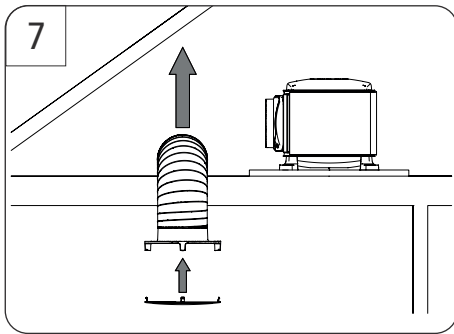
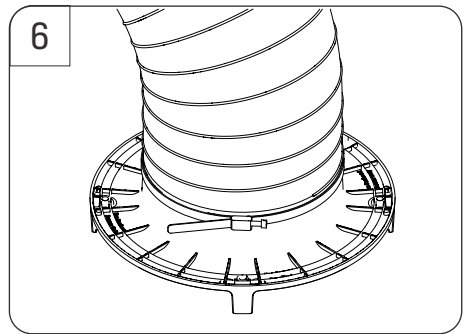
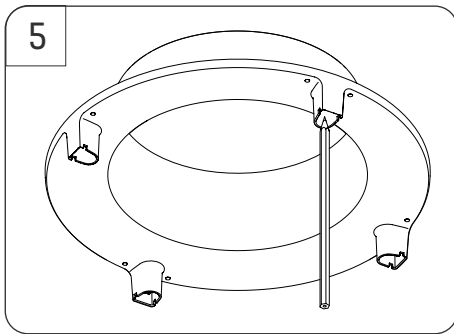

9. With the mains supply isolated, wire the power cable into the unswitched fuse spur then wire the unswitched fuse spur into the mains supply [see wiring diagram on page 4].

Use two of the 8g x 1" screws to attach the spur to a loft joist.

10. Optional step for DP-EVL-H model

The DP-EVL-H and DP-EVL-H-W units can be wired to a heater enable switch [not included]. Wire into the connection located under the unit [see Page 4, cable not included] and fit it in an accessible area.

Do NOT wire into mains or any other power source.

Use two of the 8g x 1" screws to attach the switch to the wall.

11. Reconnect the mains supply at the local isolator. After a few seconds air will begin to flow from the diffuser [see page 13 for air flow rate settings].

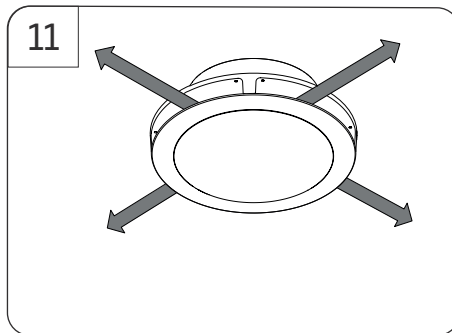
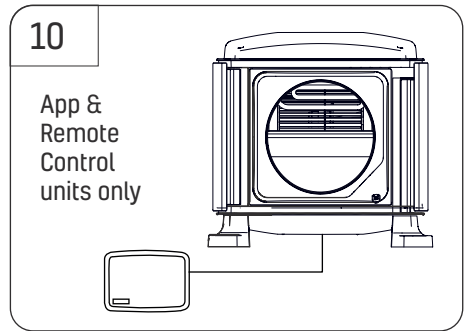
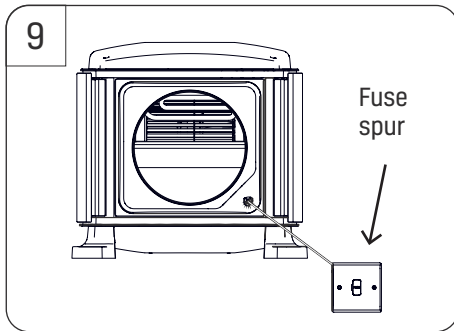

Fire Safety

Fire Kits

For installations with a floor more than 4.5m above ground, a compatible fire kit must be fitted. The kits listed below contain all the extra parts and instructions required:

Order Code	Description
KIT-PIV-SMOKE-200	200mm fire-rated diffuser for PIV units only

Smoke Alarms

For installations with a floor more than 4.5m above ground, the unit must be wired into a smoke alarm in order to switch the unit off upon the detection of smoke.

The unit can be wired into an existing smoke alarm (check compatibility with the smoke alarm manufacturer). All wiring should be completed by a competent person.

To test the installation, press the TEST button on top of the smoke alarm and keep it pressed until the PIV unit switches off (LEDs on the board go out).

KEYPAD SETTINGS

Top button

- Press to show the current air flow rate setting.
- The corresponding LED will illuminate on the keypad.
- Further presses scroll through the air flow rate settings 1, 2, 3 and 4 on a loop.
- Adjust this according to the size, type and occupancy of the property.

Bottom button

- Press to show the total running time.
- The numeric display will illuminate to show the total amount of time the unit has been running. e.g. '1234' [hours]

Wireless Remote Control (DP-EVL-H-W only)

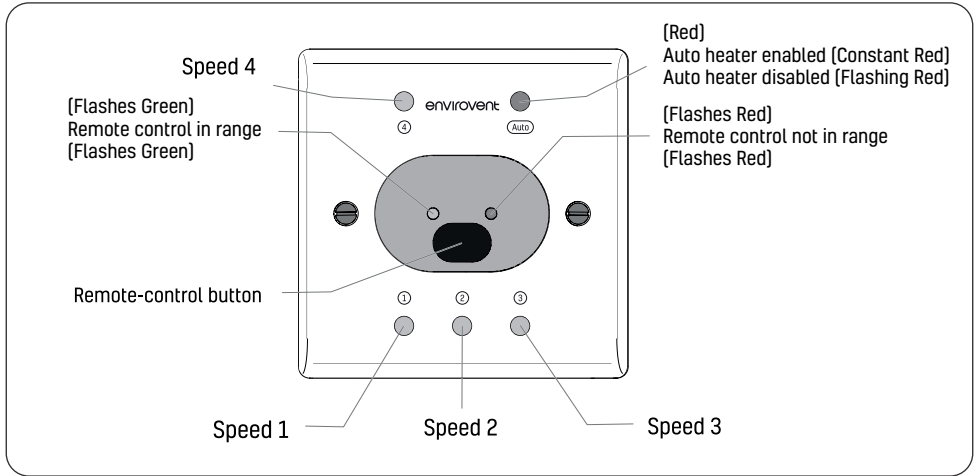

•To indicate the current status of the unit:

-Press the remote-control button once and the LEDs will light up according to the current status of the unit.

•To modify the air flow rate:

- Press the remote-control button once
- Further presses will then cycle the unit through each of the air flow rate settings - 1, 2, 3, 4
- Further presses will cycle back through the same settings

•To enable/disable the automatic comfort heater function:

- This function is enabled by default.
- Press the remote-control button once.
- Press again for 5 seconds to disable comfort heater function.
- AUTO LED will flash red for 5 seconds.
- Press again for 5 seconds to enable comfort heater function.
- AUTO LED will light constant red for 5 seconds.

Pairing an additional remote-control:

1. Turn the unit off at the isolation point.
2. Restore power; for 20 seconds from restart the unit will be in pairing mode.
3. Press the remote-control button once within the 20 seconds and the control will pair to the unit.
4. Successful pairing is indicated by a green light on the remote.

Remote-control batteries

When the battery needs to be replaced, unscrew the switch front cover. The battery is located on the back of the cover. Battery type 3V Lithium CR2032. The switch will remain paired with the unit after battery replacement. Ensure the new battery is inserted with correct polarity, and the removed battery is safely disposed of.

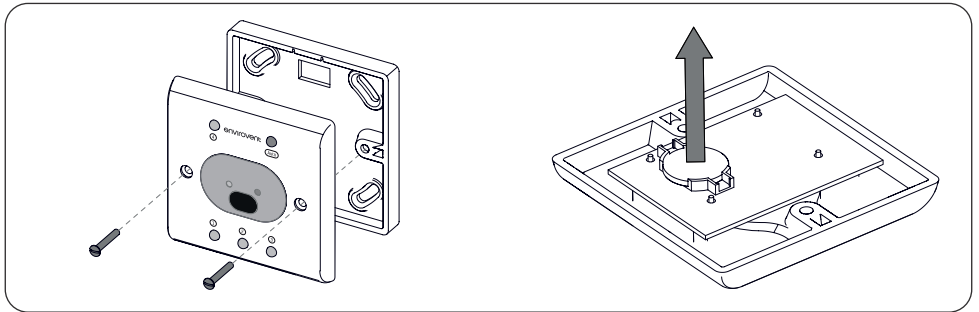

Wired comfort heater enable/disable

A switch to enable/disable the heater function can be connected up to 3 metres away from the unit. This must be a volt free contact. Do not wire the cable or switch into the Mains. When the switch is pressed on, the comfort heater function is enabled and the system will maintain the incoming air temperature at 10 °C. When the switch is pressed off, the automatic comfort heater function is disabled.

SMOKE ALARM WIRING

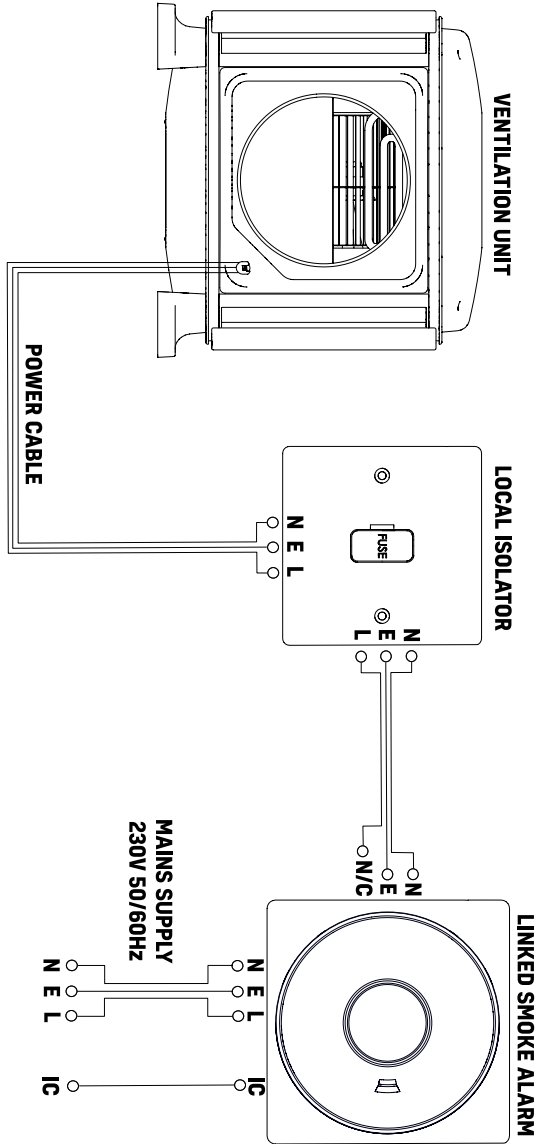

AFTER INSTALLATION THE END USER SHOULD
KEEP THIS GUIDE FOR FUTURE REFERENCE

**DO NOT
THROW AWAY**

Energy Usage and Airflow Performance

House size setting	Max air flow rate [l/s] ^a	Power usage [Watts] ^b
1.	21	4
2.	29	4
3.	38	6
4.	49	9

^a Diffuser installed without blanking plates fitted.

^b Power usage shown with heater function disabled.

Running costs

Please scan our QR code to see the annual running costs of this product.



Or visit: envirovent.com/annual-running-costs

Maintenance

EnviroVent recommend that filters are checked regularly and replaced as required. The unit should be isolated from the mains when replacing or cleaning filters.

Areas with high particulate matter for example industrial areas, or higher-grade filters will become clogged quicker and will need replacing more frequently. Spare and replacement filters must be genuine EnviroVent parts.

Failure to maintain the unit as recommended may breach the terms of the warranty. See full warranty terms and conditions for further information.

Servicing

EnviroVent recommend that all units are serviced annually to maintain optimal performance, if you would like a service or more information, please contact us on **01423 810 810**.

Spares/Accessories

Item Description	Order Code
Replacement coarse particle filter (ISO Coarse 65%)	FILTERPIV-COARSE
Replacement medium particle filter (ePM10 50%)	FILTERANC-MEDI
Replacement fine particle filter (ePM2.5 50%)	FILTERANC-FINE
Replacement coarse particle filter including carbon (ISO coarse 65% including carbon)	FILTERANC-COARSE+C
Replacement diffuser	1DIFPIV
Fixing kit	FIXINGKITEVL
Heater switch*	HEATER ENABLE SWITCH
Smoke alarm**	1ACSMOKEALARM-KIT

*Additional two core cable required. **Additional four core cable required.

Warranty

We appreciate you choosing this quality EnviroVent product, which is designed and manufactured to the highest specification in Harrogate, North Yorkshire. We are confident that you will be delighted with the performance of the system and the resulting improvement in air quality in your home after the installation of the unit.

The EnviroVent Damp Pro units are covered by a parts only 5-year warranty. Please note that conditions and exclusions apply to the warranty which can be found at www.envirovent.com/warranty

Your unit serial number

If you encounter any problems with your unit, please fee free to call us on **01423 810 810**.

What should I do if I have a problem?

If you encounter any problems with your unit, please fee free to call us on **01423 810 810**.

AFTER INSTALLATION THE END USER SHOULD
KEEP THIS GUIDE FOR FUTURE REFERENCE

**DO NOT
THROW AWAY**

AFTER COMPLETING INSTALLATION, PASS THIS GUIDE
ONTO THE END USER FOR FUTURE REFERENCE
DO NOT THROW AWAY

damppro

For all enquiries including faults, please contact your supplier

Supplied by:

Manufactured by:

EnviroVent Ltd
Harrogate West Business Park
Unit 1 Bardner Bank
Killinghall
Harrogate
HG3 2SP

T / 01423 810 810
E / info@envirovent.com
W / envirovent.com

Boxed unit weight:
7.7 kg

Unboxed unit weight:
5.5 kg

E&OE | MKT ENV357 - V16 - 02.12.25

Due to our policy of continuous innovation and improvement EnviroVent reserves the right to alter products specification and appearance without notice.

We want to hear from you

Your feedback is important to us as we strive to improve our products, services, and overall customer experience. Please email us to help us serve you better: feedback@envirovent.com