

# ATMOS®

A breath of fresh air for your home

envirovent®



# Join the Ventilation Revolution

## Bringing filtered air into your home...

Invigorating, energising and essential for well-being; filtered air is the cornerstone of good health. But modern living means the air in our homes is often far from fresh.

Condensation, mould spores, dust mites, allergens, and chemicals from household products can all be found in the air inside our homes. It's one reason so many of us suffer from headaches, nausea and tiredness, as well as more serious problems including asthma, allergies and eczema.

But there is an easy way to dramatically reduce condensation, and improve the air quality in your home.





## Home Ventilation Systems for a **Healthier Indoor Atmosphere**

ATMOS® from EnviroVent brings clean air back into your home. As the filtered air gently circulates around your home, the stagnant, polluted air is diluted, creating a healthier home and a healthier you.

# A Difference You Can Feel



- Significantly reduces condensation
- Reduce irritants found in indoor air, including mould spores, dust mites, and chemicals
- Improve the unpleasant symptoms caused by polluted air

Breathing in the cocktail of pollutants often found in indoor air can have a serious impact on your health.

Headaches, breathing problems, a constantly blocked or runny nose, tiredness or unexplained illnesses can all be made worse by inhaling contaminated air.

Meanwhile condensation caused by moisture build-up from washing, bathing and cooking adds to the problems. Condensation not only looks unsightly but can lead to mould, a common culprit behind many illnesses.

Luckily, it's an easy problem to solve thanks to ATMOS® - the home ventilation system that brings filtered air into your home.

## Before installing ATMOS®

Before installing ATMOS®, your home could be filled with a mixture of:



### **Condensation**

which can lead to unsightly mould

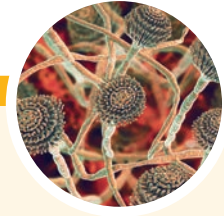

### **Mould Spores**

a common cause of breathing problems



### **Dust Mites**

a trigger for asthma, eczema, and allergies



### **Chemical Compounds**

from household products



### **Formaldehydes**

found in furniture and carpets



### **Radon**

natural radioactive gas causing lung cancer

## After installing ATMOS®

Within just 48 hours of installing ATMOS®, you will start to notice the difference to your home.

### **The benefits of an ATMOS® Home Ventilation System:**

- Improves indoor air quality and helps control condensation and mould
- Reduces pollutants and allergens
- Helps to eliminate mould
- Stops streaming windows
- Removes musty odours
- Can help ease symptoms for asthma/ respiratory sufferers
- Reduces dust mite populations
- Reduces Radon levels
- Can reduce heating costs

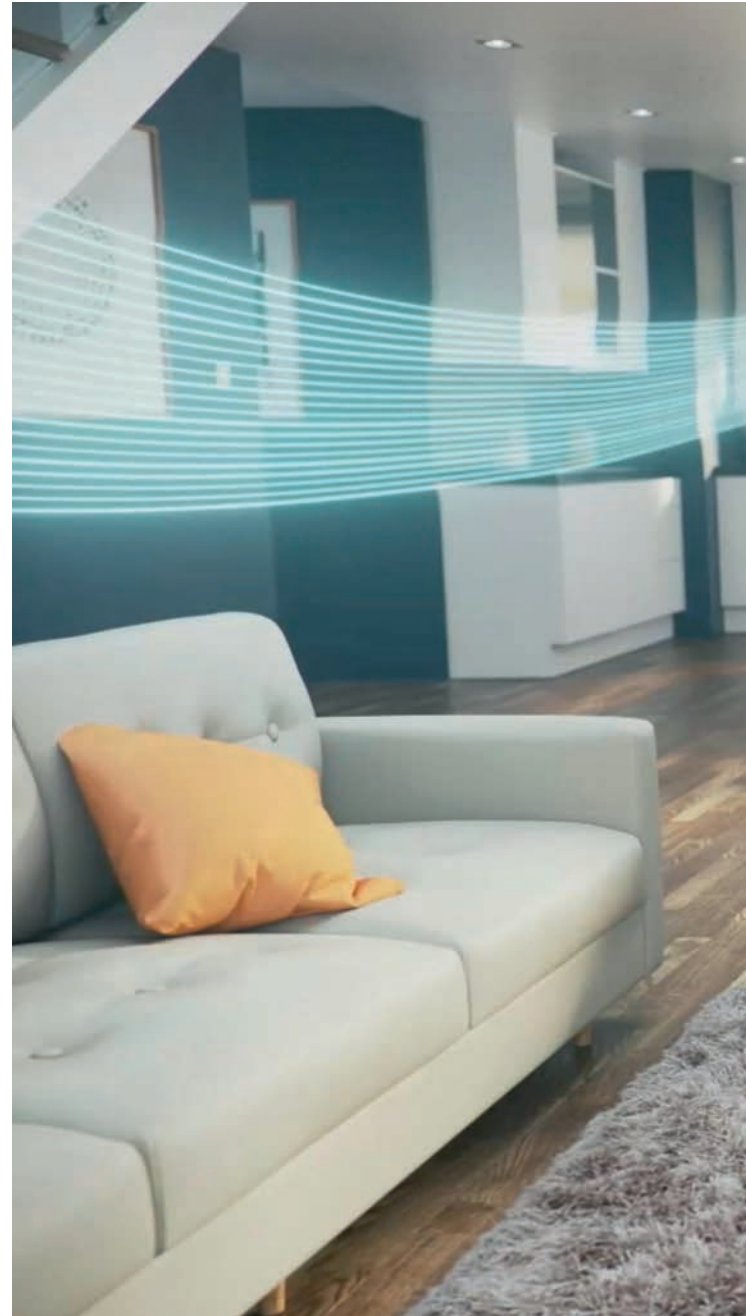



**10**  
year  
warranty

# An ATMOS for Every Home

## ATMOS® from EnviroVent is a range of PIV units for the home

PIV stands for 'positive input ventilation' which is simply the name given to a ventilation system that provides a continuous flow of filtered air from outside into the property.

Invented almost 50 years ago, PIV has been installed into over 1 million homes across the UK.

There's a choice of models to suit every property.



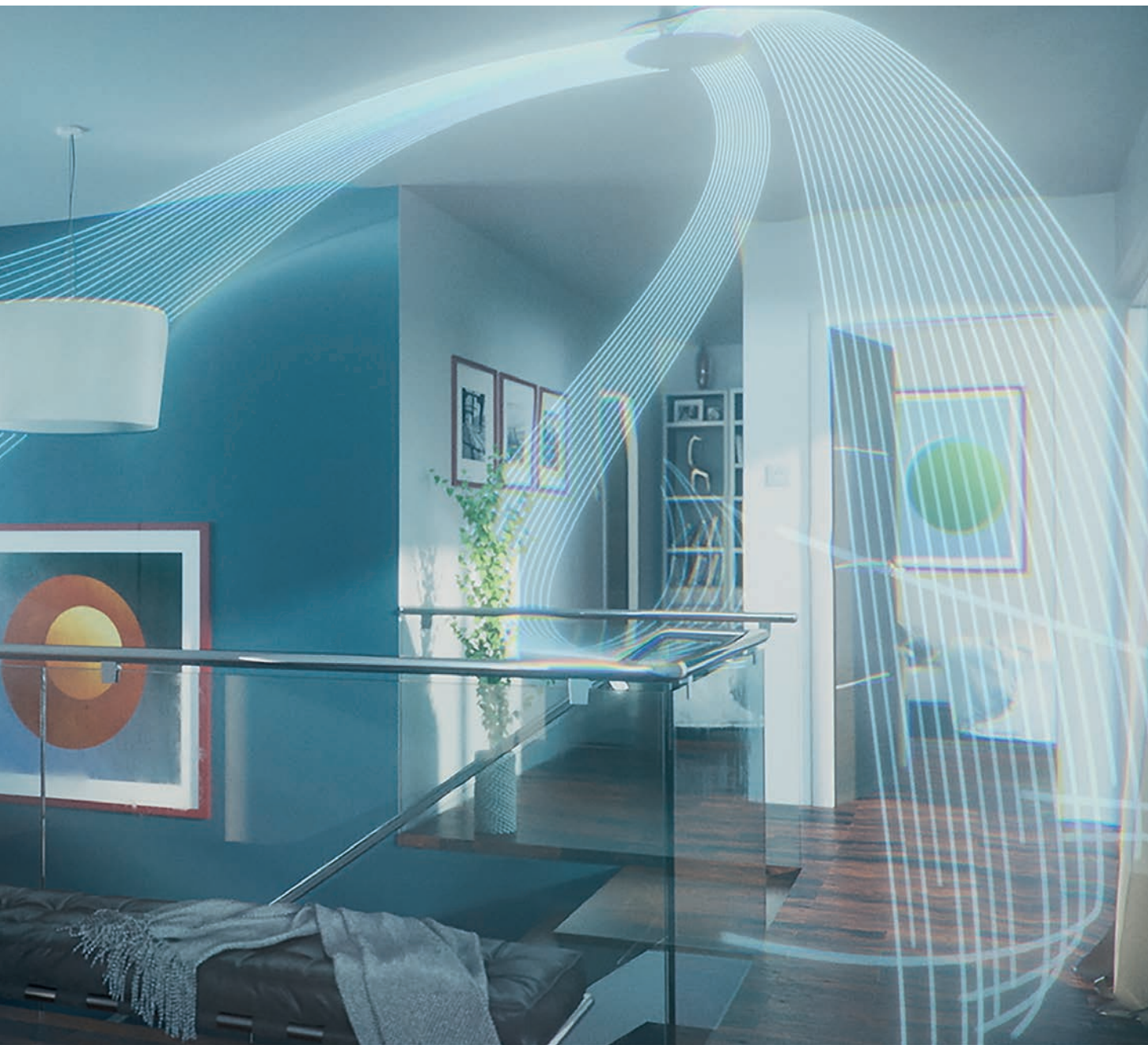

## ATMOS ATL / ATL-A / ATL-W

The ATMOS gently ventilates the home from a central position on a landing. With an intelligent comfort heater built in, the incoming air is not only filtered, but also a comfortable temperature.

---



## ATMOS AIR ATL-AIR / ATL-AIR-A / ATL-AIR-W

When summer temperatures start to rise, ATMOS Air helps ventilate a property in the warmer months.

As the temperature in the loft space rises above 25°C, this unit sources colder air from outside. This not only cools the property during warmer weather, but also maintains ventilation continuously throughout the year.

---



## ATMOS DUAL ATL-D / ATL-AD / ATL-WD

Some homes might need a little extra help to deal with condensation and mould throughout several rooms.

That's where ATMOS Dual comes in. With two outlets, the unit provides filtered air into multiple areas, even when you have rooms that are not connected to the central hallway.

---



## ATMOS AIR DUAL ATL-AIR-D / ATL-AIR-AD / ATL-AIR-WD

With two outlets, this model is ideal for homes where there is severe condensation and mould in multiple rooms or in rooms located away from the central hallway.

It's also a great choice for keeping the home ventilated during summer months. When the temperature in the loft hits 25°C, it automatically draws cooler air from outside.



## ATMOS® **INLINE** ATL-I

The ATMOS® Inline units are designed specifically for properties with air restricted loft spaces to draw air from outside throughout the year.

---



## ATMOS® **WALL** ATF / ATF-A / ATF-W

The ATMOS® Wall is designed to provide whole home ventilation and improve indoor air quality for homes without a loft space.

The unit introduces an almost imperceptible air supply throughout the living space to transform a stale atmosphere into a fresh and healthy environment.

---



## ATMOS® **App Units**

The ATMOS® App units provide full controllability through the myenvirovent App. [Order codes -A]



## ATMOS® **Remote Control**

The ATMOS® units can be controlled with a remote control boost switch to increase the airflow when required. [Order code -W]



# ATMOS<sup>®</sup> Loft Unit

Enjoy good  
indoor air  
quality all  
year round

## How ATMOS<sup>®</sup> works?

ATMOS<sup>®</sup> is a simple yet effective system that replaces contaminated air in your home with filtered air.



## Here's how it works:

- 1 Our professional installers position ATMOS® in your loft space.
- 2 A neat hole is cut in the ceiling of your landing and the discreet air vent is placed into position.
- 3 ATMOS® draws air from the loft and filters it before pushing it down into the home.
- 4 Filtered air gently circulates around your home, reducing the pollutants and irritants that cause illness and allergies.
- 5 Humidity levels are also controlled to help eliminate condensation and mould.

## Once installed, you can simply forget it's there & enjoy the benefits it brings.

- > Quiet operation
- > Low running costs
- > Easy installation
- > 10-year warranty

## Annual Running Costs

Please scan our QR code to see the annual running costs of this product.



Or visit:  
[envirovent.com/  
annual-running-costs](https://envirovent.com/annual-running-costs)

## Energy Saving Benefits

The ATMOS range is built to last with low energy costs. It can even help reduce heating costs throughout your home.

## How does it do this?

The air in your loft space is typically 3°C higher than the air outside. Meanwhile, the air at ceiling level can be up to 7°C higher than the air at ground level. By gently redistributing this warmer air through the rooms of your home, the heat is brought back into your living space, creating a saving on your annual heating costs.

As ATMOS deals with condensation, you don't have to open windows, so you won't need to turn the heating up to compensate in winter.

## A Sustainable Choice

Our ATMOS range has been designed using sustainable components that can easily be recycled. This means we ensure the plastics used in our products never end up on landfill sites.

# ATMOS® WALL for Flats and Apartments

## Circulate filtered air throughout the property

### How ATMOS® WALL works?

ATMOS® WALL circulates filtered air throughout the property and transforms the stagnant and stale atmosphere into a fresh, healthy environment.

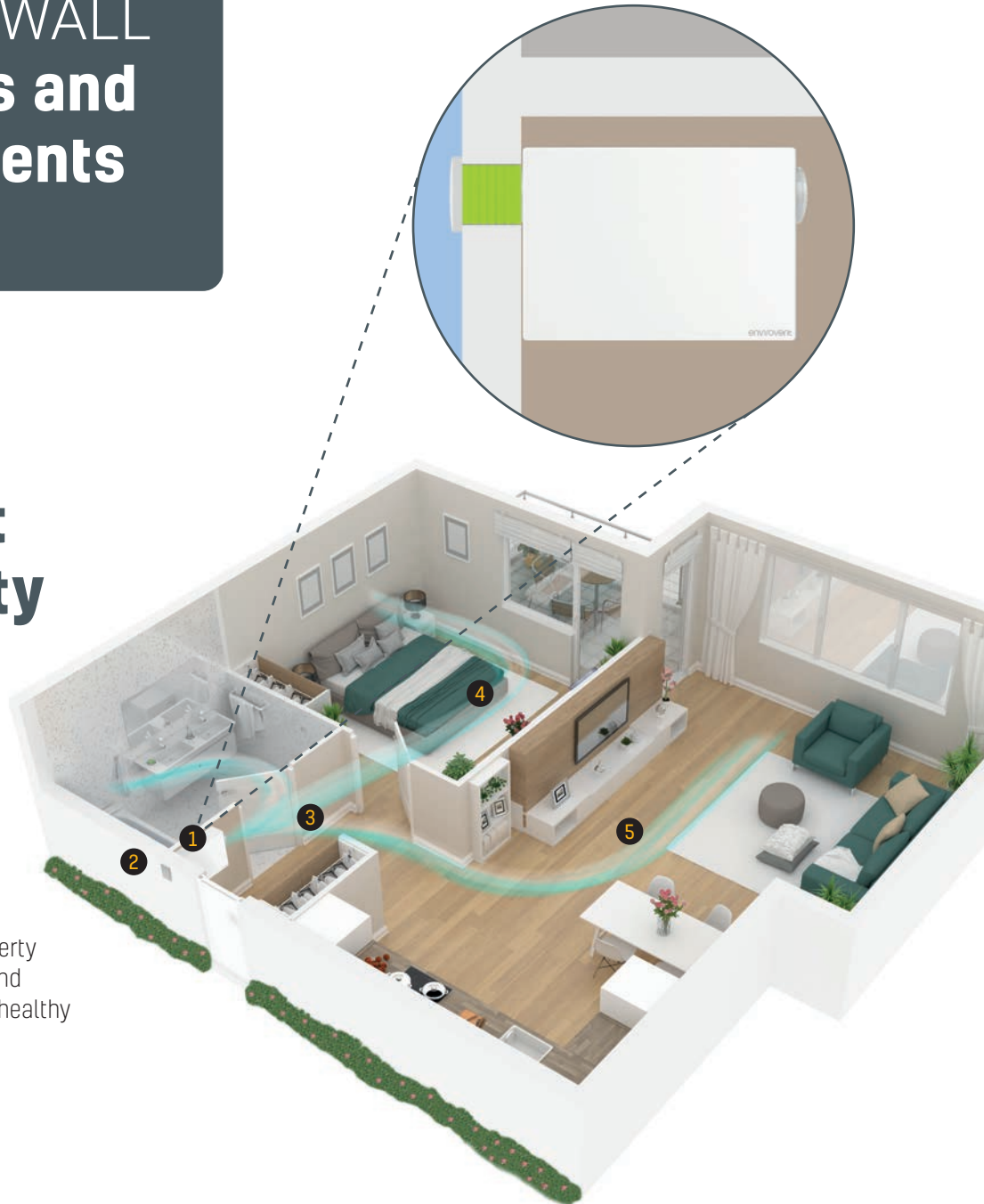

## Here's how it works:

- 1 Our professional installers position ATMOS® WALL in your designated space.
- 2 A neat hole is cut in the exterior of your home and the discreet air vent is placed into position.
- 3 ATMOS® WALL draws air from outside and filters it before pushing it down into the home.
- 4 Filtered, air gently circulates around your home, reducing the pollutants and irritants that cause illness and allergies.
- 5 Humidity levels are also controlled to help eliminate condensation and mould.

## Once installed, you can simply forget it's there & enjoy the benefits it brings.

- > Quiet operation
- > Low running costs
- > Easy installation
- > 10-year warranty\*

\*10-year warranty is offered if this product is installed by EnviroVent. 5-year warranty is offered if this product is not installed by EnviroVent.

## Annual Running Costs

Please scan our QR code to see the annual running costs of this product.

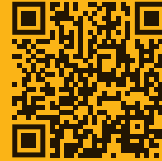

Or visit:  
[envirovent.com/  
annual-running-costs](https://envirovent.com/annual-running-costs)

## Energy Saving Benefits

The ATMOS® WALL range is built to last with low energy costs. It can even help reduce heating costs throughout your home.

## How does it do this?

The ATMOS® WALL draws air into the dwelling from outside and filters it before being delivered into the property. Moisture laden air is diluted, displaced and replaced with tempered and filtered air.

As ATMOS® WALL deals with condensation, you don't have to open windows, so you won't need to turn the heating up to compensate in winter.

## A Sustainable Choice





Our ATMOS® WALL has been designed using sustainable components that can easily be recycled. This means we ensure the plastics used in our products never end up on landfill sites.

## Control at your Fingertips

ATMOS® WALL is available in 3 versions. The standard version [ATF] provides fit & forget functionality. Once installed you can leave it to operate autonomously. ATF-W comes with a remote control boost switch to increase the airflow when required and ATF-A provides full controllability through the myenvirovent App.

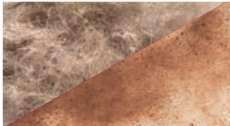
# ATMOS<sup>®</sup> Filters

All ATMOS<sup>®</sup> units come with a filter to minimise contaminants entering the home, they reduce allergens such as pollen & improve the overall quality of the air being supplied to the dwelling.

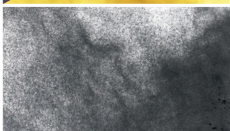
Filter Classification (ISO 16890)	Description & Usage	
ISO Coarse 65%	Prevents against particles such as hair, sand, fluff and larger pollen grains.	
ISO ePM10 50%	Our medium grade filter captures stone dust and other lightweight airborne particles.	
ISO ePM2.5 50%	Our finest-grade filter captures small airborne particles, substantially reducing allergens and spores.	
ISO Coarse 65% plus carbon	Larger particle and pollen filter including carbon. These are used to prevent odours and for highly polluted areas.	
ISO ePM2.5 50% plus carbon	Finer particle filter including carbon. These are used to prevent odours and for highly polluted areas.	



### ATMOS® LOFT & DUAL\*

FILTERPIV-COARSE (Default)	ISO Coarse 65%
FILTERANC-MEDI	ISO ePM10 50%
FILTERANC-FINE	ISO ePM2.5 50%
FILTERANC-COARSE+C	ISO Coarse 65% including carbon

### ATMOS® AIR & AIR DUAL\*

FILTERMIVAS-COARSE (Default)	ISO Coarse 65%
------------------------------	----------------

### ATMOS® WALL

FILTERWALL-MEDIUM (Default)	ISO ePM10 50%
FILTERWALL-FINE	ISO ePM2.5 50%
FILTERWALL-FINE+C	ISO ePM2.5 50% including carbon

To see further information on filters used across EnviroVent products and coding information please use the QR code or **[www.envirovent.com/filters](http://www.envirovent.com/filters)**  
Please get in touch for pricing and availability.

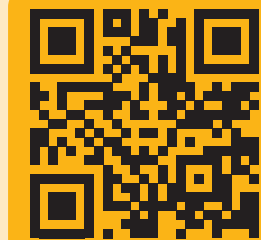

\*For Inline Atmos units, please contact EnviroVent who will provide filter information.

# ATMOS® Puts You in Control

Once ATMOS® is installed, you don't have to do a thing - just sit back and enjoy the benefits of filtered air. But if you do want to take control, we have extras that give you enhanced features and functionality.

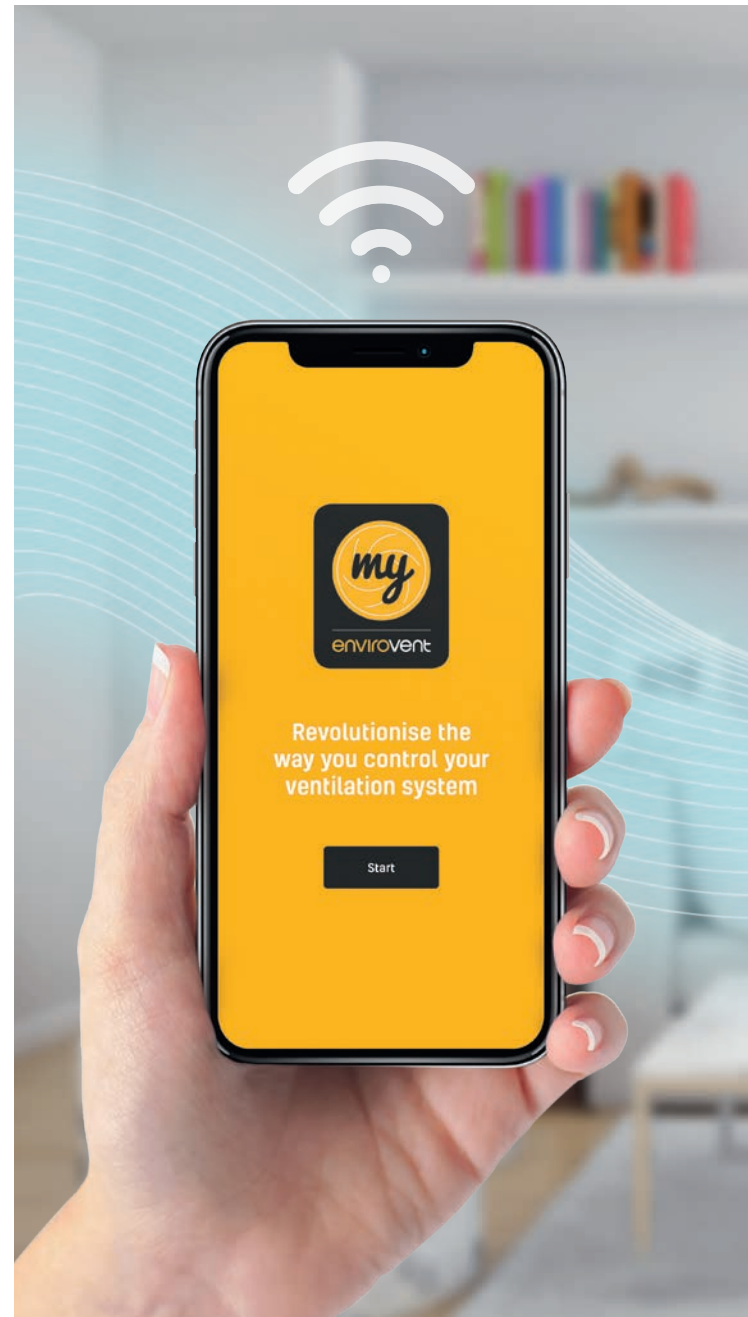

# myenvirovent.

The **myenvirovent app** gives you complete control of your ATMOS® ventilation system at the touch of a button.

- Filter indicator
- Adjustable boost functionality
- Hours run meter
- Adjustable airflow
- Adjustable heater
- Control summer mode
- Enable or disable the heater
- Use the app with most smartphones



## AirSens®

AIR QUALITY SENSORS



For those who like to keep an eye on air quality levels, **AirSens®** provides an easy-to-read colour-coded display, showing the current air quality at any time:

**Red** - Poor air quality

**Amber** - Medium air quality

**Green** - Good air quality

Available in three models, **AirSens®** can detect and control levels of:

- **Carbon Dioxide (CO<sub>2</sub>)**
- **Volatile Organic Compounds (VOCs)**
- **Relative Humidity**
- **Temperature**

Your ATMOS® unit can be linked directly to the **AirSens®** sensor. This means it reacts automatically to changes in air quality, instantly supplying more filtered air into the property to maintain a healthy environment when needed.

# Installation is a Breeze

If you're ready to improve indoor air quality and reduce condensation and mould, we're here to help.

Your local ventilation specialist will carry out a detailed home survey to assess the problems you're currently facing. This includes taking a reading of the relative humidity levels using a hygrometer and ray temp. They will then discuss the best methods for ventilating your home to improve the air quality. They can also show you samples from the range, while answering any questions you may have.

By assessing the air quality and the unique requirements of your property, we'll help you choose the right ATMOS® unit for your home.

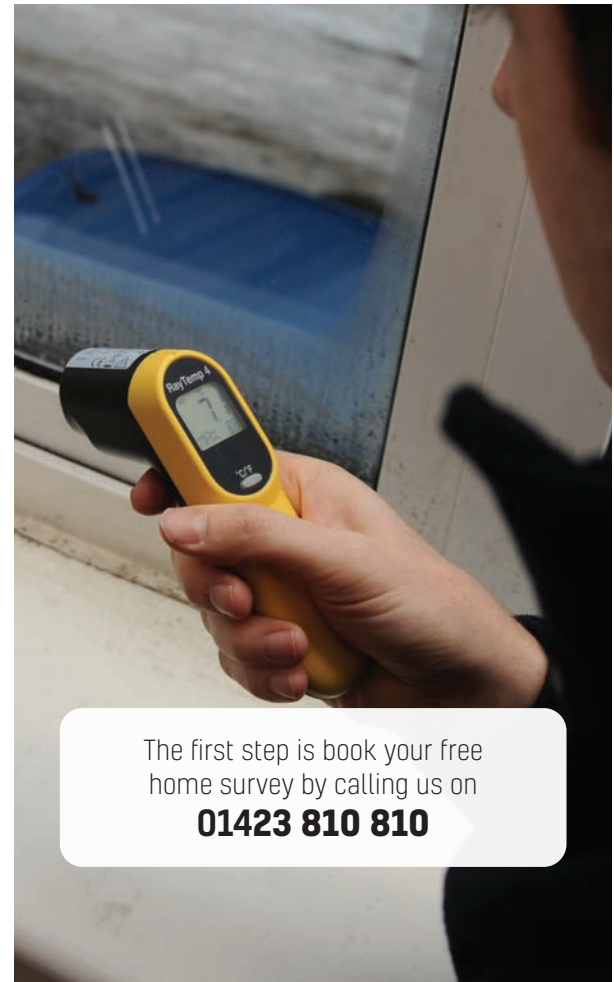

The first step is book your free home survey by calling us on  
**01423 810 810**

Once we've identified the best ATMOS® for your home, our professional installers will take care of everything.

Installing ATMOS® typically takes less than two hours. Our installers are considerate, friendly, and tidy. They wear protective shoes and will vacuum the area after the installation.

We'll provide full instructions but once installed, you can just let ATMOS® do its thing while you sit back and enjoy all the benefits of filtered air.

Call today on **01423 810 810** to book your free home survey.



### **Specifiers and landlords:**

If you'd like to chat about fitting ATMOS® into your property, give us a call on **01423 810 810** and we'll be happy to talk through the options.

# Did You Know?

---

The air in our homes can play host to a staggering array of things which are detrimental to our health.

We inhale and exhale approximately 17,000 times a day. By sealing up our homes, we are breathing in a cocktail of contaminants and pollutants.



The average family produces 112 pints of moisture each week through cooking, bathing, ironing and breathing - which can all add to condensation problems.



Over 1 million homes across the UK are benefiting from having a positive input ventilation unit installed, making it one of the most popular methods of ventilating homes.



37% of asthma sufferers and 10% of allergy sufferers see their symptoms worsen in the presence of mould and fungal spores.

*[[www.asthma.org.uk](http://www.asthma.org.uk)]*



50% of all illnesses are either caused or aggravated by poor indoor air quality.

*[New Horizons Project D03 -  
Technical Report ODPM]*



81% of people are at risk of suffering from breathing or skin conditions because of poor air quality inside the home.

*[[www.myhealthmyhome.com](http://www.myhealthmyhome.com)]*



The average person spends 90% of their time indoors, 70% of which is in their own home. That's why it's important to create a healthy indoor atmosphere.

*[[www.epa.gov](http://www.epa.gov)]*

# ATMOS® Loft Units

## TECHNICAL SPECIFICATION

### Applications

#### ATMOS®

ATMOS® units supply filtered air from the loft space into a central hallway at a continuous rate via a ceiling mounted diffuser, which comes with two blanking plates to maximise efficiency of airflow and is designed to aid in distribution of heat from ceiling level. The unit provides ventilation in order to improve indoor air quality and reduce condensation related problems taking maximum advantage of the benefits of solar gain from within the loft space.

#### ATMOS® Air

ATMOS® Air units have an additional facility to draw air from outside during the warmer months when the temperature in the loft space exceeds 25°C. This provides efficient perception cooling into the property and maintains the required level of ventilation continuously throughout the year.

#### ATMOS® Dual

ATMOS® Dual units supply filtered air from the loft space into multiple areas of a property at a continuous rate via two ceiling mounted diffusers. The system provides ventilation in order to improve indoor air quality and reduce condensation related problems taking maximum advantage of the benefits of solar gain from within the loft space.

#### ATMOS® Air Dual

ATMOS® Air Dual units supply filtered air from the loft space into multiple areas of a property at a continuous rate via two ceiling mounted diffusers. The system provides ventilation in order to improve indoor air quality and reduce condensation related problems taking maximum advantage of the benefits of solar gain from within the loft space.

### Motor

Designed to operate continuously at a pre-set rate, incorporating DC motor technology with sealed for life ball bearings.

### Filter

The unit has a synthetic fibre based filter made to ISO Coarse 65% (G4) in accordance with the ISO 16890 standard.

### Servicing / Maintenance

EnviroVent recommend that units should be serviced annually to maintain optimal performance and that filters should be checked regularly and cleaned as and when required.

### Standard Functions

Integral 'Intelligent Low Temperature' comfort heater. Designed to temper the air during periods of low external temperatures.

### Controls

At installation, the unit will be set by the installer using the integrated control panel to run at one of the 4 fixed speeds [1,2,3,4] depending on the size and occupancy of the property, a variable speed option is also available. The unit will run continuously all year round on this setting. An integral hours run meter is fitted on all units for monitoring of operational life and verification of usage.

### Optional controls:

**Model ATL-W** - These units are supplied with a wireless remote control. The user can view the current status of the unit, increase or decrease the airflow as required and enable/disable the auto comfort heater.

**Model ATL-A** - These units are app-enabled. Once the user activates the boost switch in the myenvirovent app, the airflow is boosted for 20 minutes (default time period) before returning to the commissioned setting. Other functions within the myenvirovent app include: Airflow setting, Filter change indicator, Hours run meter, Auto comfort heater enable/disable.

0-10V variable control input for use with the AIRSENS is available on both W and A versions.

### Warranty

Covered by a 10 year warranty, subject to the completion of specified maintenance.

### UK Building Regulations

Conforms to the requirements of the UK Building Regulations and the Technical Standards for Ventilation.

### Accreditations

CE and UKCA Marked.

## ATMOS Dimensions [mm]

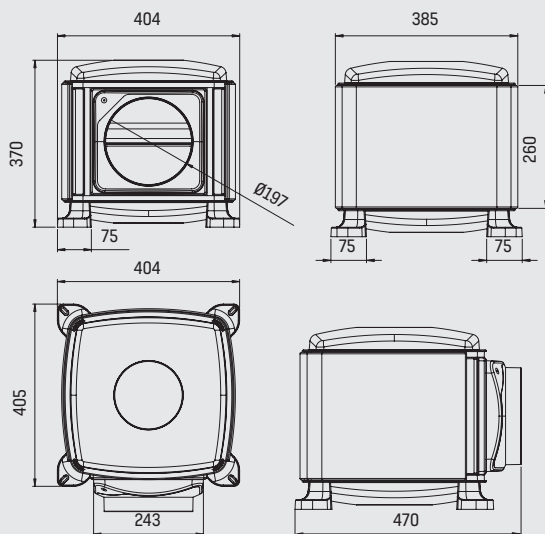

## ATMOS<sup>®</sup> AIR Dimensions [mm]

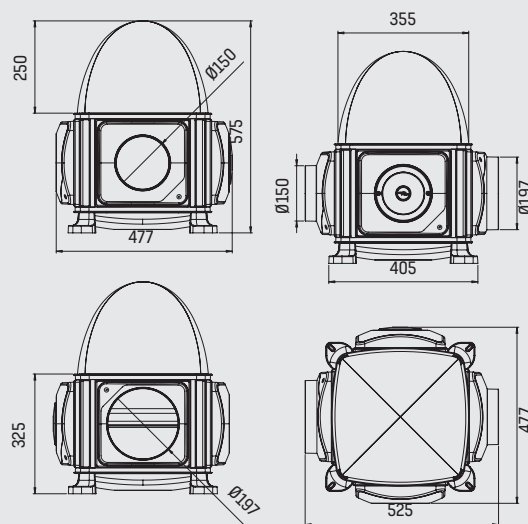

## ATMOS<sup>®</sup> DUAL Dimensions [mm]

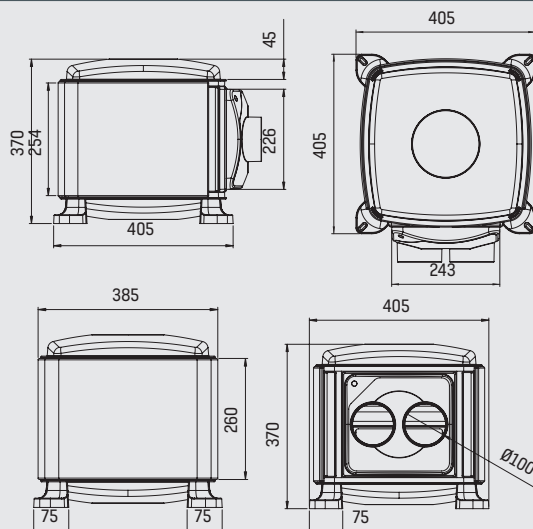

## ATMOS<sup>®</sup> AIR DUAL Dimensions [mm]

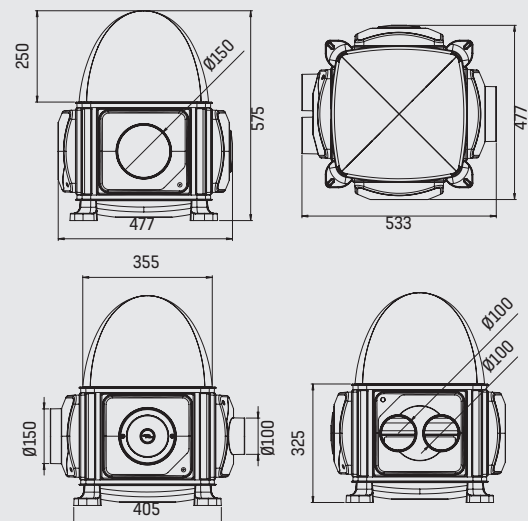

## ATMOS<sup>®</sup> Performance Curve

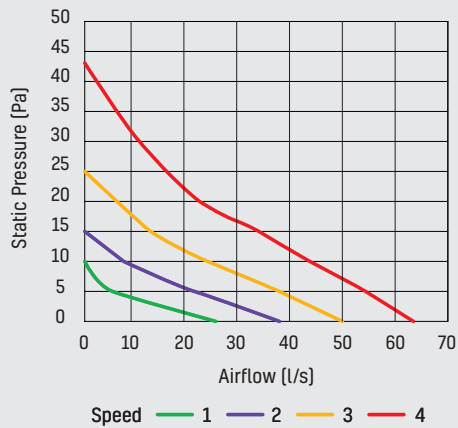

## ATMOS<sup>®</sup> AIR Performance Curve

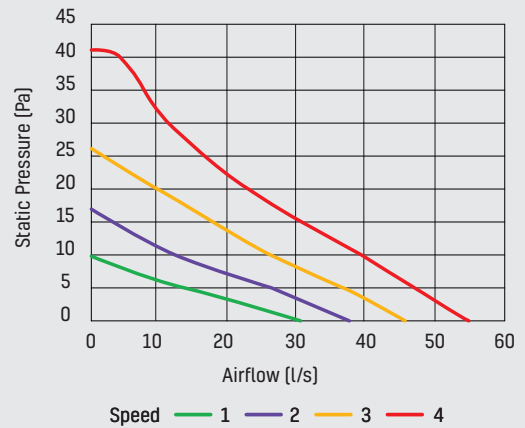

## ATMOS<sup>®</sup> DUAL Performance Curve

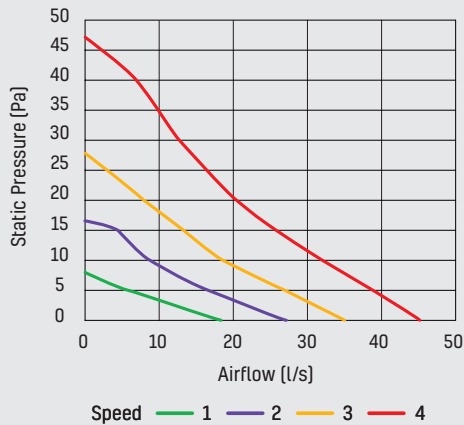

## ATMOS<sup>®</sup> AIR DUAL Performance Curve

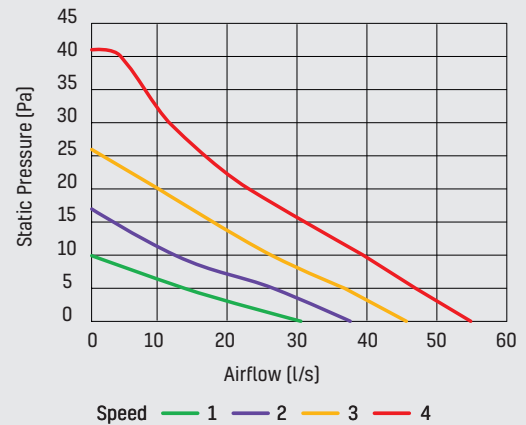

# ATMOS® WALL

## Applications

The ATMOS® wall mounted unit is manufactured in the UK and is designed for installation into flats and apartments to meet the Building Regulations Approved Document F.

ATMOS® units supply filtered air from outside into a central location within the property at a continuous rate. Air is supplied via a grille that is designed to maximise the efficiency of airflow. The unit provides ventilation in order to improve indoor air quality and reduce condensation related problems such as mould.

## Motor

Designed to operate continuously at a pre-set rate, incorporating DC motor technology with sealed for life ball bearings.

## Filter

The unit has an ePM10 50% pleated filter. Optional ePM2.5 50% and Carbon ePM2.5 50% filters available.

## Servicing / Maintenance

EnviroVent recommend that units should be serviced annually to maintain optimal performance and that filters should be checked regularly and cleaned as and when required.

## Standard Functions

Integral 'Intelligent Low Temperature' comfort heater. Designed to temper the air during periods of low external temperatures.

## Controls

At installation, the unit will be set by the installer using the integrated control panel to run at one of the 4 fixed speeds (1,2,3,4) depending on the size and occupancy of the property, a variable speed option is also available. The unit will run continuously all year round on this setting. An integral hours run meter is fitted on all units for monitoring of operational life and verification of usage.

### Optional controls:

**Model ATF-W** - These units are supplied with a wireless remote control. The user can view the current status of the unit, increase or decrease the airflow as required and enable/disable the auto comfort heater.

**Model ATF-A** - These units are app-enabled. Once the user activates the boost switch in the myenvirovent app, the airflow is boosted for 20 minutes (default time period) before returning to the commissioned setting. Other functions within the myenvirovent app include: Airflow setting, Filter change indicator, Hours run meter, Auto comfort heater enable/disable.

0-10V variable control input for use with the AirSens® sensor is available on both W and A versions.

## Warranty

Covered by a 10 year warranty if installed by EnviroVent, subject to the completion of specified maintenance. If this product is not installed by EnviroVent, a 5-year warranty is offered.

## UK Building Regulations

Conforms to the requirements of the UK Building Regulations and the Technical Standards for Ventilation.

## Accreditations

CE and UKCA Marked.

## ATMOS® WALL Dimensions [mm]

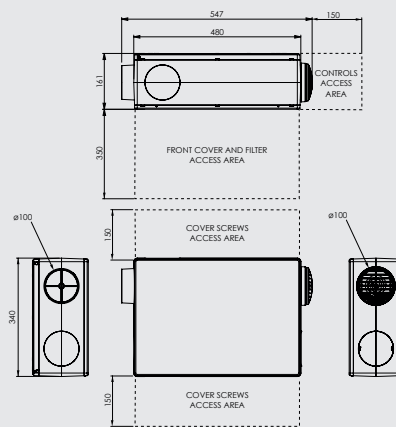

## ATMOS® WALL Performance Curve

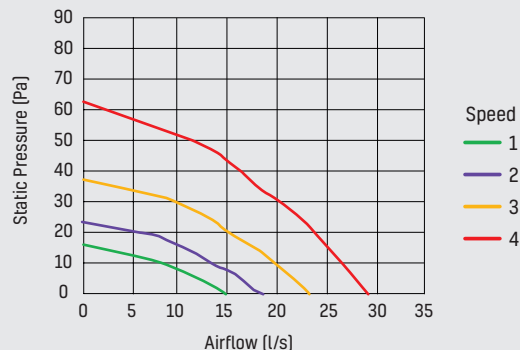

# ATMOS® Units

## PERFORMANCE DATA

### ATMOS®

Incoming Air Temp. [°C]	Fan Speed Setting	Specific Fan Power [SFP]	Airflow [l/s]	Power Usage [W]	Outlet Noise dB(A) @3m
<19	1	0.17	21	4	<15
	2	0.15	29	4	<15
	3	0.16	38	6	<15
	4	0.19	49	9	15

### ATMOS® AIR

Incoming Air Temp. [°C]	Fan Speed Setting	Specific Fan Power [SFP]	Airflow [l/s]	Power Usage [W]	Outlet Noise dB(A) @3m
<19	1	0.14	22	3	<15
	2	0.14	29	4	<15
	3	0.15	35	5	<15
	4	0.18	43	8	15
<25	1	0.28	28	7.9	-
	2	0.26	35	9.2	-
	3	0.25	44	10.9	-
	4	0.27	52	14	-

### ATMOS® DUAL

Incoming Air Temp. [°C]	Fan Speed Setting	Specific Fan Power [SFP]	Airflow [l/s]	Power Usage [W] (4)	Outlet Noise dB(A) @3m
<19 (1) (2)	1	0.24	15	4	<15
	2	0.22	20	4	<15
	3	0.21	26	6	<15
	4	0.25	34	9	<15

### ATMOS® AIR DUAL

Incoming Air Temp. [°C]	Fan Speed Setting	Specific Fan Power [SFP]	Airflow [l/s]	Power Usage [W]	Outlet Noise dB(A) @3m
<19	1	0.16	19	3	<15
	2	0.18	24	4	<15
	3	0.23	30	7	<15
	4	0.31	36	11	15
<25	1	0.28	26	7.3	-
	2	0.31	32	9.8	-
	3	0.33	38	12.6	-
	4	0.36	44	15.7	-

### ATMOS® WALL

Incoming Air Temp. [°C]	Fan Speed Setting	Specific Fan Power [SFP]	Airflow [l/s]	Power Usage [W]	Outlet Noise dB(A) @3m
<19	1	0.34	12	4	<30
	2	0.30	15	4.5	<30
	3	0.30	19	5.5	32
	4	0.33	24	8	<40

1. Above 19°C the unit increases airflow rates per setting by 10%
2. Power usage with Comfort Heater disabled
3. Data for unit with duct and grilles





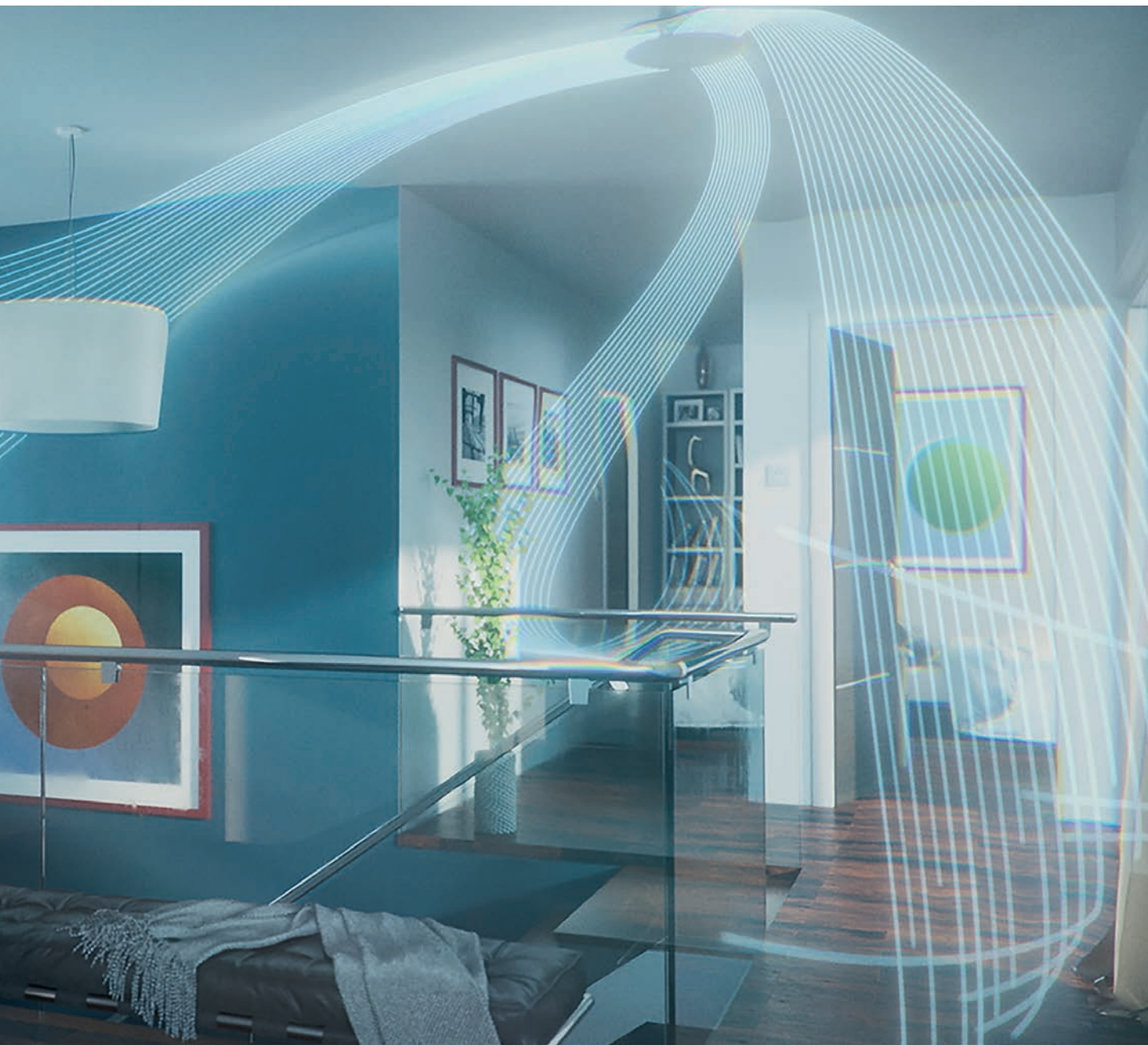

# envirovent<sup>®</sup>

Leading Manufacturer & Supplier of Innovative & Sustainable Ventilation Systems

EnviroVent Ltd  
Harrogate West Business Park  
Unit 1 Bardner Bank  
Killinghall, Harrogate  
HG3 2SP

T / 01423 810 810  
E / info@envirovent.com  
W / www.envirovent.com

Due to our policy of continuous innovation and improvement, EnviroVent reserves the right to alter products specification and appearance without notice.

E&OE | MKT ENV355 - V10 - 02.12.25

Copyright © EnviroVent Ltd 2025



Follow us on  
**facebook**



Find us on  
**LinkedIn**



Watch us on  
**Youtube**



Follow us on  
**Instagram**

**SCAN ME**  
for the  
website

