

AFTER INSTALLATION THE END USER SHOULD
KEEP THIS GUIDE FOR FUTURE REFERENCE
DO NOT THROW AWAY

envirovent®

ENERGISAVA® 260
WALL MOUNTED VERSION
INSTALLATION GUIDE

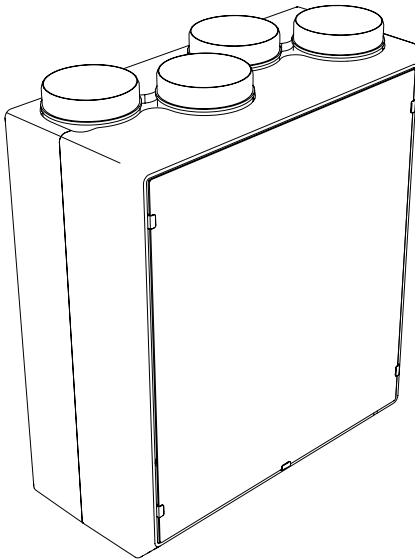



Safety

Read and understand these instructions carefully before beginning installation. The unit should only be installed by a competent person.

Electrical Connection

The unit requires a continuous electrical power supply. Connection to the fixed wiring must be made outside the unit in a suitable location. The unit must be able to be disconnected from the mains supply after installation. The unit must be earthed and a suitable isolator having a minimum contact separation of 3.0mm must be used to provide isolation for the unit.

The power cable running into the unit must remain the supplied flexible cable if the power cable becomes damaged, it must be replaced by EnviroVent, an authorised service agent for your region/country, or a similarly qualified person in order to avoid a hazard. Do not remove or tamper with any electronic components inside the unit.

All wiring must comply with Building Regulations and the current IET Wiring Regulations (BS7671 in the UK) or equivalent standards for other countries. The final installation should be examined and tested by a qualified electrician.

This product is not suitable for use with a Type AC RCD 

Location

Check there is space for the unit in your chosen location including room for access and future servicing of the unit. The unit must not affect the operation of open-flue appliances. Consider the external vent locations in relation to open-flues from appliances e.g. boilers. You must ensure the external supply grilles are positioned away from open flues to avoid drawing harmful gases into the property. Consult your local regulations or a qualified gas engineer. EnviroVent recommends at least 2m clearance.

Users

This unit is not intended for use by persons [including children] with reduced physical, sensory or mental capabilities or lack of experience and knowledge, unless they have been given supervision and usage instruction by a person responsible for their safety. Children should be supervised to ensure they do not play with the unit. Cleaning and user maintenance must not be performed by children.

Diagrams

Overall unit dimensions and minimum area required for access & maintenance [mm].

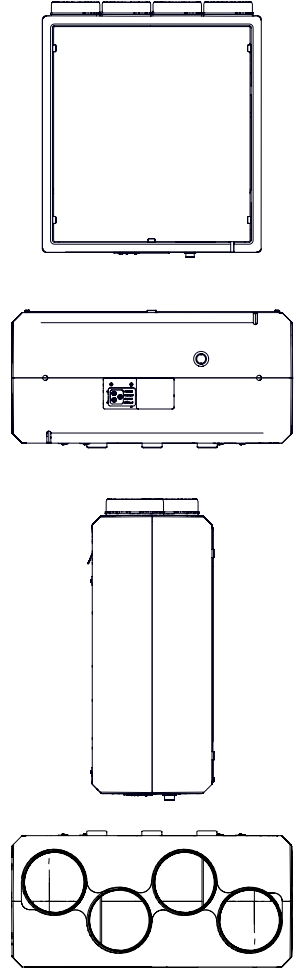
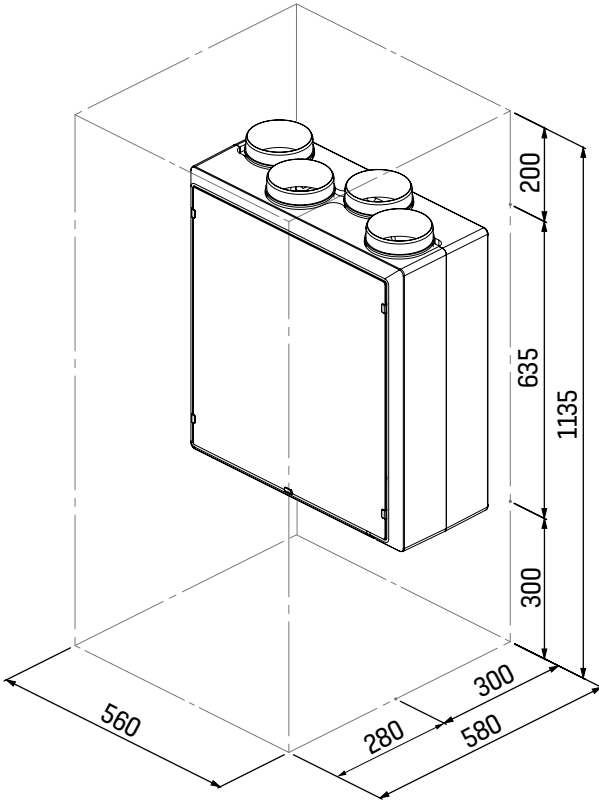

The energiSava® 260 spigots are compatible with $\varnothing 125$ mm duct.

AFTER INSTALLATION THE END USER SHOULD
KEEP THIS GUIDE FOR FUTURE REFERENCE

**DO NOT
THROW AWAY**

envirovent®

Diagrams

WIRING

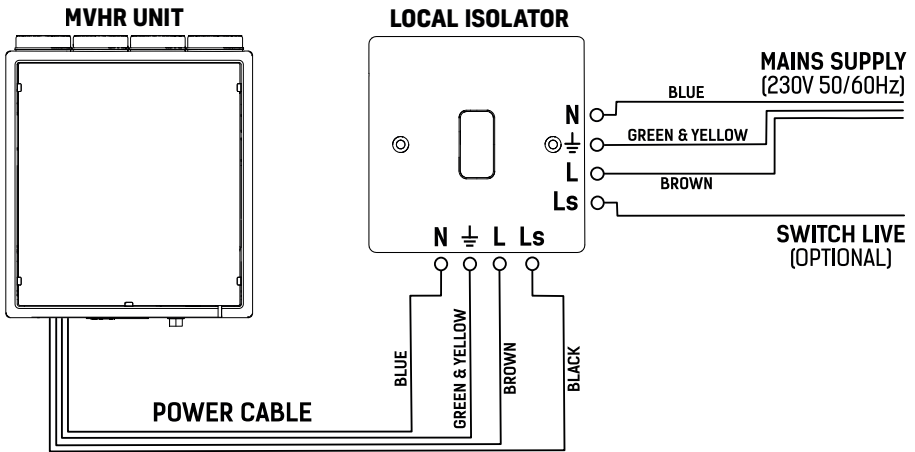

The local isolator must be connected to the mains as part of the fixed wiring. Connect the cores of the power cable to the matching terminals on the local isolator (3A fuse spur or similar)

The black switch live core of the mains cable can be wired to a switch input such as a light switch. When the switch is turned on, the boost function is engaged. When the switch is turned off, the unit will return to normal running mode. In this configuration a triple pole isolator must be used.

About the energiSava® 260

The energiSava® 260 is an MVHR unit (Mechanical Ventilation with Heat Recovery). It is ideal for medium to large sized properties with a kitchen and up to 5 additional wet rooms. The unit is capable of delivering a maximum airflow of 86l/s (310m³/hr) and a maximum system pressure in excess of 390Pa.

The unit will help to create a fresh and healthy living environment by supplying filtered air into a property through supply valves. Moist, stale air is removed out of the property through extract valves.

The heat exchanger inside the unit transfers waste heat energy from the extracted air to the supplied air in order to improve the thermal efficiency of the property and reduce heating costs.

When outdoor temperatures are low, the frost protection feature automatically reduces the supply air flow rate to ensure the heat exchanger inside the unit does not freeze.

The Intellitrac® humidity tracking function monitors the humidity levels in the extracted air and will automatically increase the supply and extract air flow rates when the humidity levels rise. Once the humidity levels are lower the air flow rates will return to the normal rate.

The automatic, thermal bypass helps to control the temperature of air entering the home on warmer days.

The energiSava® 260 includes a switch live function. When wired through the lighting switch of a room (such as a bathroom) the unit will enter boost mode whenever the light is turned on.

Box Contents

energiSava® 260

1x energiSava® 260 unit
1x Remote control
1x Instruction guide
1x User guide
1x Wall mounting bracket
5x Screws 8g x 2.0"
5x Plasterboard plugs
2x Wall mount spacers
2x Screws 10g x 0.5"

energiSava® 260 App

1x energiSava® 260 app unit
1x Instruction guide
1x User guide
1x App guide
1x Wall mounting bracket
5x Screws 8g x 2.0"
5x Plasterboard plugs
2x Wall mount spacers
2x Screws 10g x 0.5"

energiSava® 260 Basic/ Remote Switch

1x energiSava® 260 unit
1x Wired Remote Switch (RS only)
1x Instruction guide
1x User guide
1x Wall mounting bracket
5x Screws 8g x 2.0"
5x Plasterboard plugs
2x Wall mount spacers
2x Screws 10g x 0.5"

Pre - Installation Checklist

- Does the unit fit in the space where it will be installed?
- Is there room to connect ducts to the spigots without tight duct bends?
- Is there room to access and replace the filters after installation?
- Are there any obstructions above or below the locations where the input and extract valves are to be fitted?
- Is the mounting surface strong enough to support the unit?
- Is the mounting surface level?
- Are there adequate facilities to connect the unit condensate drain to the internal waste system of the property?

Installation

1. Hold the unit in the chosen location and check there is space for ducts, condensate drainage, filter and keypad access.
2. Once you are satisfied with the position, fix the wall bracket in place. **Use 5 8gx2.0" screws and 5 plasterboard plugs.**
3. Now attach the two wall spacers to the back of the unit. This must be done to ensure that any condensate drains out of the unit correctly. **Use 2 10gx0.5" screws.**
4. Place the unit onto the wall bracket. Hold the end of the tie down cable flush to the wall then screw it in place. This will ensure the unit is not accidentally knocked out of position.

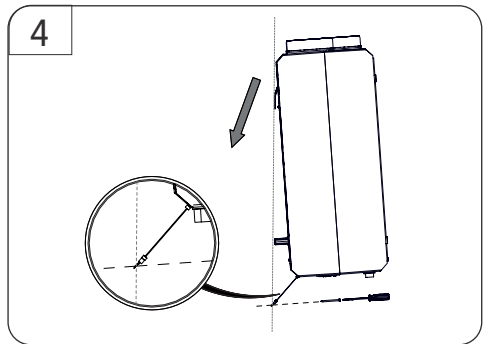
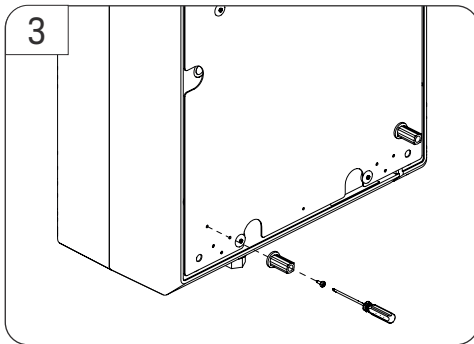
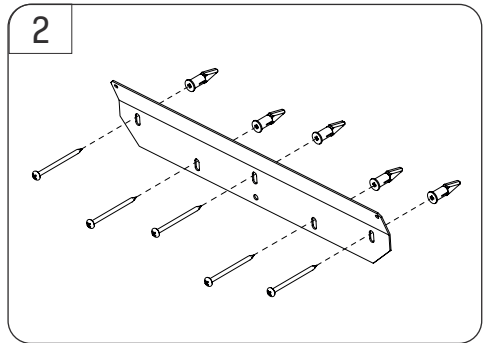
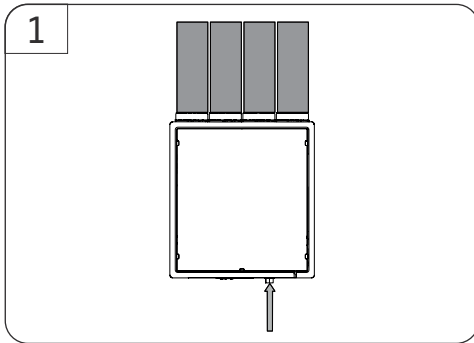

AFTER INSTALLATION THE END USER SHOULD
KEEP THIS GUIDE FOR FUTURE REFERENCE

**DO NOT
THROW AWAY**

envirovent®

5. Make a water-tight connection between the drainage connector on the unit and the waste water system in the property. A suitable non-return device must be fitted to ensure air and waste water from the drain system do not flow back up into the unit. The drainage must be fitted with a minimum 5 degree fall away from the unit.

5a. LH Units

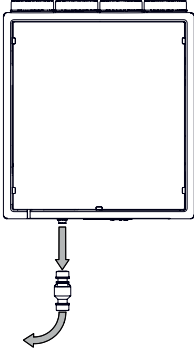

5b. RH Units

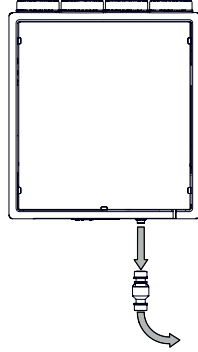

Installation

1. Fit the external supply and extract terminations.
2. Fit the supply and extract valves inside the property.
3. Fit the ductwork between the external terminations, the MVHR unit and the supply and extract valves.

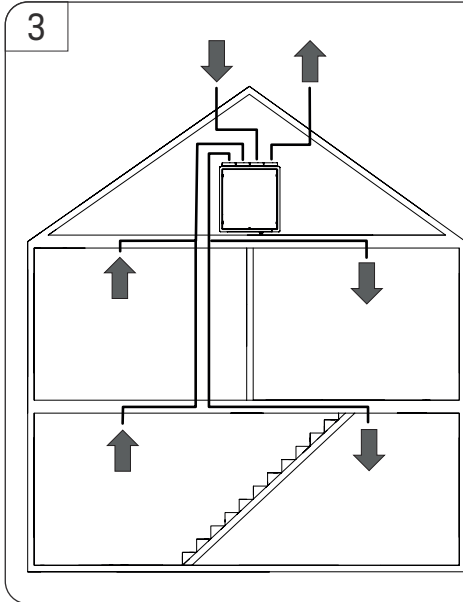
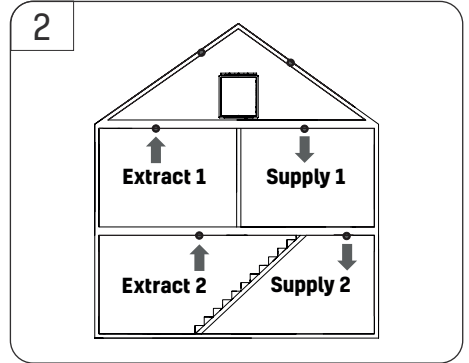
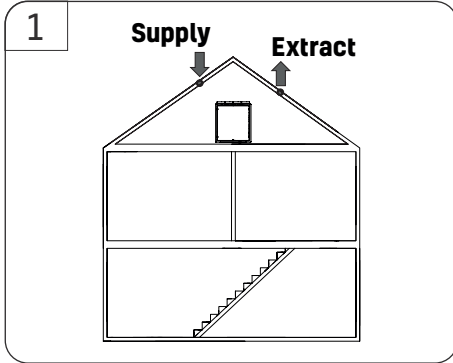

Ductwork should be fitted in accordance with the Approved Document F of building regulations. (Example RH unit configuration shown).

Ducts to and from atmosphere and through unheated spaces need to be insulated.

All ductwork should be as large a diameter as possible (min. 125mm) and use rigid duct or a suitable semi-rigid duct system such as EnviroVent Fast Track.

4. Connect each duct path to the spigot.

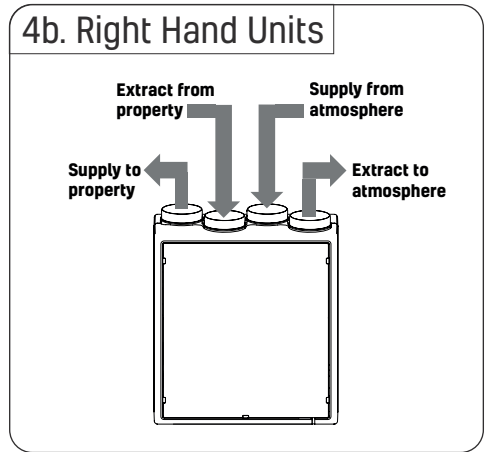
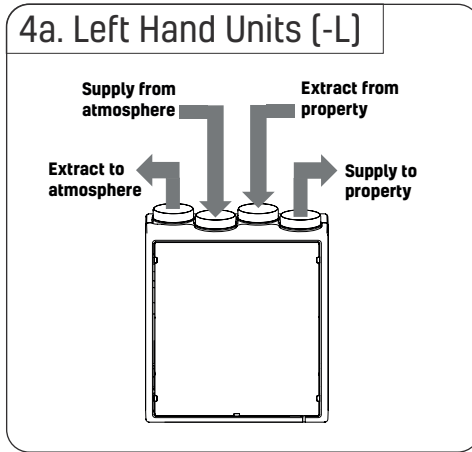

5. Ensure that the spigots are sealed & protected from the ingress of water into the inlets & outlets.

6. With the mains supply isolated, wire the unit to the local isolator as per the wiring diagram on page 4 and in accordance with the local wiring regulations. When the power is turned on, air will begin flowing into the property after a few seconds.

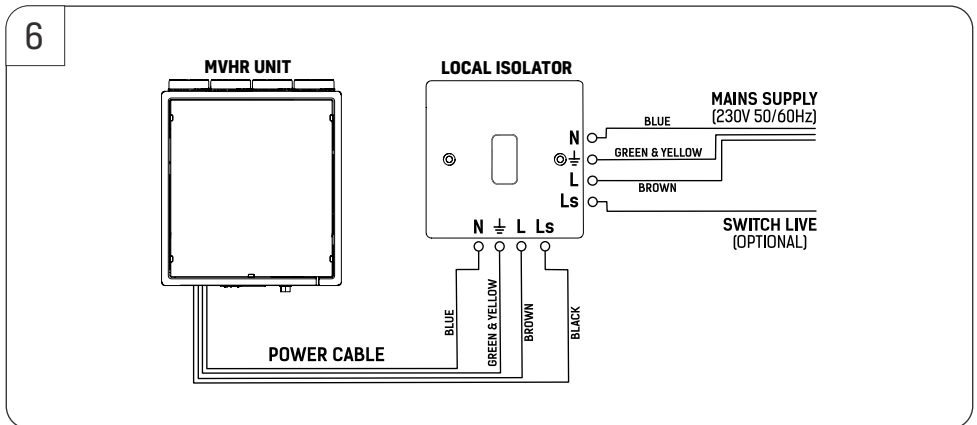

7. If you are installing a remote switch (-RS) unit:

- a) Open the switch ensuring the ribbon cable remains connected to the PCB.
- b) Screw the switch to the wall in an accessible location.
- c) Replace the lid and tighten the two screws.

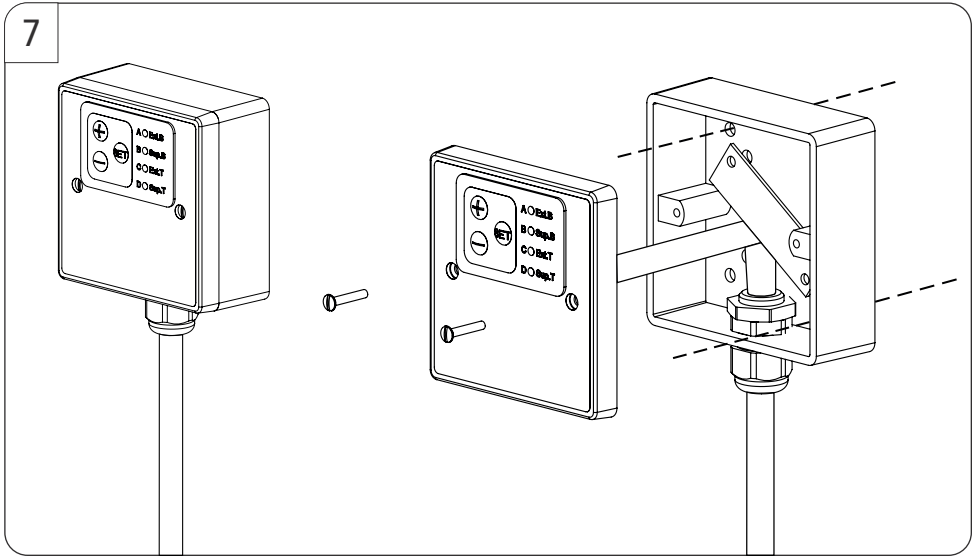

AFTER INSTALLATION THE END USER SHOULD
KEEP THIS GUIDE FOR FUTURE REFERENCE

**DO NOT
THROW AWAY**

envirovent®

Commissioning

All maintenance and building works should be complete before commissioning this MVHR unit. This will avoid any other major disturbance to the installation or high volumes of dust or debris being drawn into the system. Do not commission the MVHR unit until it is fully installed including power, ductwork, internal valves and external vents.

MVHR systems must be commissioned in accordance with Approved Document F of the Building Regulations for England and Wales. For MVHR commissioning guidance in other countries, please refer to the relevant local Building Regulations for that country.

- Determine the required ventilation rates. For guidance see Approved Document F of the building regulations for England and Wales.
- During normal running mode, press the SET button for 4 seconds to enter commissioning mode. (Humidity and temperature sensor input is disabled temporarily while the unit is in commissioning mode).
- LEDs B C D will light and LED A will flash indicating that the extract boost flow rate is being modified.
- Fully open all supply/extract valves then measure the air flow rate at all system extract points using a calibrated air flow meter capable of measuring in l/s or m³/hr.
- Add the extract rates from all rooms together then compare this value to the calculated whole building boost extract ventilation rate.
- Use the + and - buttons to increase or decrease the flow rate in order to meet the calculated whole building extract ventilation rate.

- Now adjust the individual valves to extract at the appropriate rate for each wet room.
- Press the SET button once to move on to the next flow rate. The flashing LED indicates which flow rate is being modified.
 - A: Extract Boost
 - B: Supply Boost
 - C: Extract Trickle
 - D: Supply Trickle
 - AC: Speed Three Extract
 - BD: Speed Three Supply
- Commission the unit in the order shown below, using the previous steps for adjusting air flow rates and valves.

[When maximum speed setting is reached, the LED will flash faster. When the minimum speed setting is reached the LED will flash slowly].

Step	Flow Rate	Actions
1	Extract Boost	Lock the valves. Record the air flow rates.
2	Supply Normal [Trickle]	Lock the valves. Record the air flow rates.
3	Supply Boost	Do not adjust the valves. Record the air flow rates.
4	Extract Normal [Trickle]	Do not adjust the valves. Record the air flow rates.
5	Speed Three Extract	Do not adjust the valves. Record the air flow rates
6	Speed Three Supply	Do not adjust the valves. Record the air flow rates

- When commissioning is complete for all six flow rates, press SET for 4 seconds to return to normal running mode. If this is not done, the unit will automatically return to normal running mode after 60 minutes of inactivity and the current settings will be saved.

Wi-Fi App myenvirovent

App enabled units can be controlled using the myenvirovent app on Apple and Android devices. A separate instruction guide for the myenvirovent app is included in the box. The guide can also be accessed from within the app. Once the unit has been installed, refer to this guide for connection and further settings. The SSID and password information for the unit is printed on the back page of the app guide and also on a label attached to the bottom of the unit.

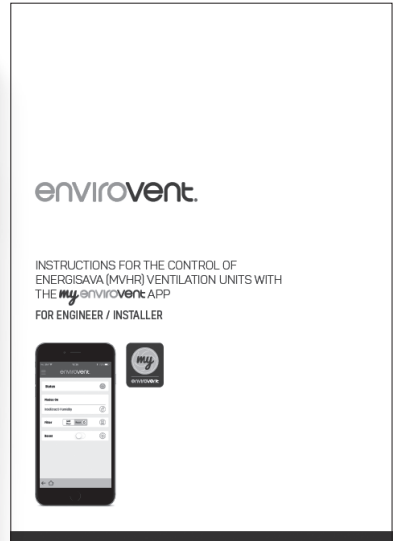
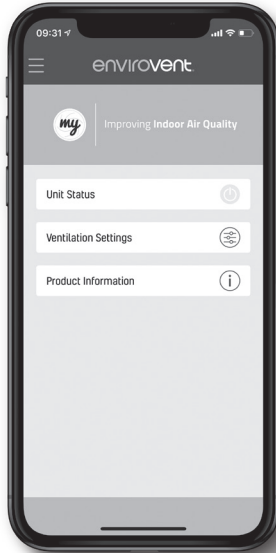

Wireless Remote Control

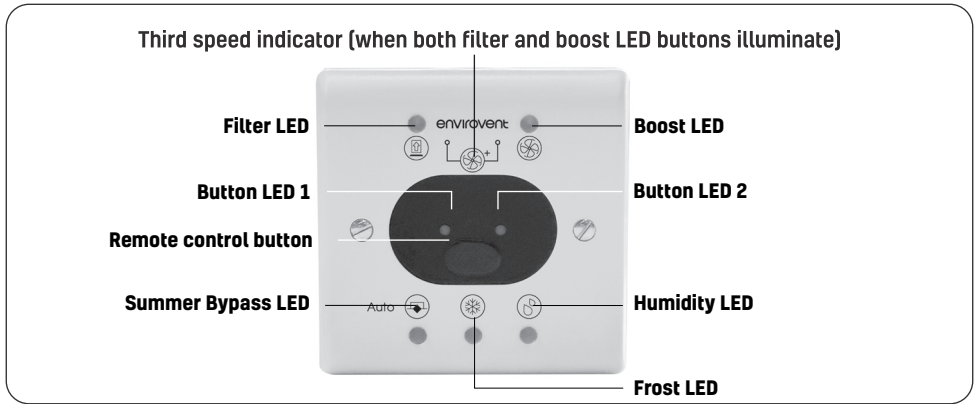

To view the current status of the unit:

- Press any button to wake the remote control and the relevant LEDs will light up according to the current status of the unit.

To manually activate or deactivate the speed functions:

- Press any button to wake the remote control.
- Press the button again, the boost LED (top right) will flash red. After 2 seconds the unit will enter boost mode for 20 minutes then automatically return to trickle mode. To deactivate the boost mode, repeat this sequence again.
- If speed three is required, press the button to wake the unit up. Press the unit twice more to activate this setting. The top two LEDs will flash and then become solid. After 2 seconds the unit will enter speed three for up to 8 hours. After the button is pressed to wake the unit up, pressing the button again will deactivate speed three.
- If the switch live connection is turned on then boost cannot be cancelled until the switch live connection is turned off.
- Speed three cannot be activated whilst the energisava 260 is in boost mode (and vice versa). The boost speed setting will need to be deactivated before selecting the alternative speed through the sequences above.

To manually activate or deactivate the summer bypass function:

- Press any button to wake the remote control.
- Press the button again twice. The bypass LED will flash [red]. After 2 seconds the unit will enter bypass mode for 24 hours then automatically return to the normal running mode.
- To deactivate the summer bypass mode, repeat the above steps.

To switch between auto and manual summer bypass modes:

- Wake the remote control.
- Press and hold the button for 5 seconds, the filter LED will flash green.
- Press the button once to switch to edit the summer bypass mode.
- Press and hold the button for 5 seconds to switch between summer bypass modes.
- Auto = Bypass LED constant, Manual = bypass LED flashing.

Filter indicator and reset:

- If on waking the remote control the filter LED flashes [green], the filters need to be replaced. Contact EnviroVent to order new filters.
- After replacement filters have been installed, wake the remote control.
- Press and hold the button for 5 seconds, the filter LED will flash green.
- Press and hold the button for 5 seconds again to reset the filter, the filter LED will flash rapidly for 2 seconds to confirm the filter reset.

Pairing an extra remote control:

- Turn the unit off at the isolation point.
- Restore the power to the unit. For 20 seconds from restarting, the unit will be in pairing mode.
- Press the button on the new remote control once within the 20 seconds and the remote control will pair to the unit.
- If LED 2 lights green, the pairing has succeeded.

To reset/wipe wireless remote control memory:

- Press the + button on the unit control panel for 10 seconds.
- LEDs A,B,C and D will all flash.
- Press the button on any EnviroVent wireless remote control.

The memory of any linked wireless remote controls is wiped.

Fault indication:

- If on waking the remote control all LEDs are flashing [red], a fault has occurred with the MVHR unit. If it persists, call EnviroVent on 01423 810 810 for further help.

When the remote control battery need to be replaced, remove the two screws then open the remote control. The battery is located on the back of the front cover. Replace the battery then clip the rear cover back on. The switch will remain paired with the unit after battery replacement. The remote control uses 1x CR2032 battery. Dispose of the discarded battery in a safe manner.

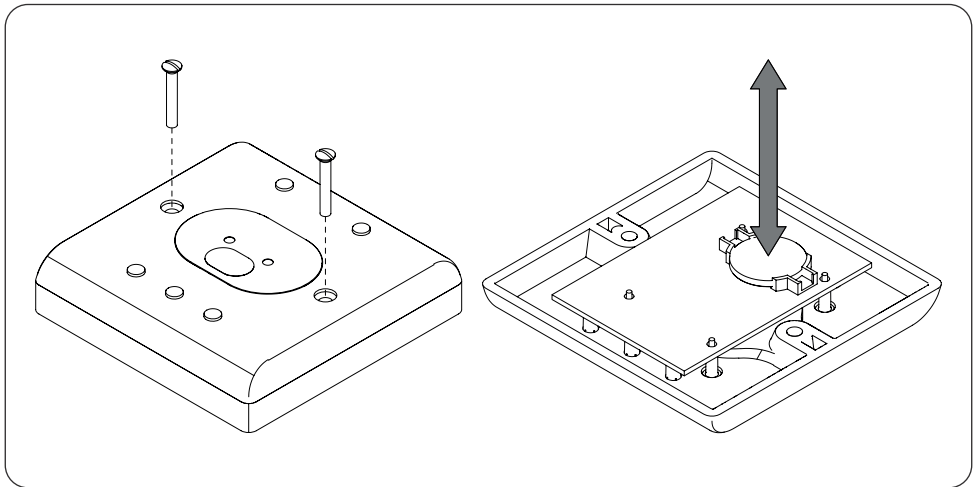

Technical Specification

Spigot diameters	125mm
Maximum air flow rate	86l/s [310m ³ /hr]
Maximum power consumption	145W
Electrical Supply	230V Single Phase 50Hz / 60Hz
Filter grade	ISO Coarse 45% [G3]
Boxed unit weight	16kg
Unboxed unit weight	14kg

Airflow Performance

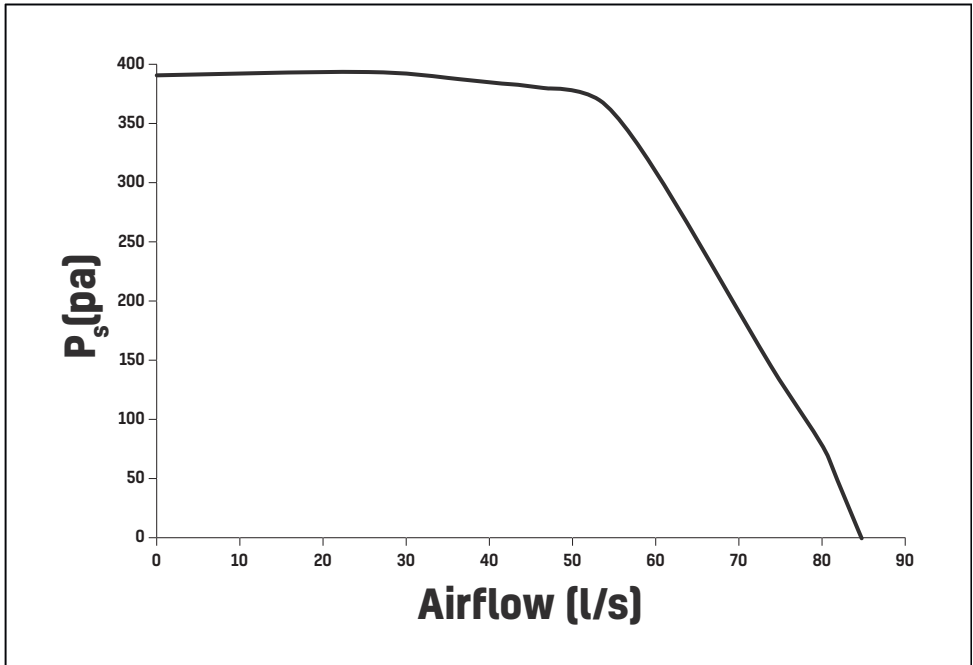

Post-Installation Checklist

- Installation instructions have been understood. Contact EnviroVent on 01423 810 810 if you require further technical help.
- Ductwork diameter is 125mm or larger throughout the property.
- Minimal amounts of flexible duct have been used in the installation.
- All ducts, valves, vents and drainage points are connected, mechanically fixed and sealed.
- Both filters are inserted into the filter slots on the unit.
- The unit is securely fixed with adequate space left for servicing.
- Condensate drain is securely connected to the waste water system, a non return device is correctly fitted and pipework has been water tested before connection to the MVHR unit.
- All major building works have been completed prior to commissioning.
- Spigots & ducting are sealed & protected against the ingress of water.
- Supply and extract air flow rates have been commissioned with a calibrated anemometer to meet Approved Document F of the Building Regulations for England and Wales.
- Commissioning air flow rate data has been recorded.
- The occupants of the property are familiarised with the operation and maintenance of the system.

Filter Maintenance

EnviroVent recommend that filters are checked regularly and replaced as required. The unit should be isolated from the mains when replacing or cleaning filters.

Areas with high particulate matter for example industrial areas, or higher-grade filters will become clogged quicker and will need replacing more frequently. Spare and replacement filters must be genuine EnviroVent parts.

Failure to maintain the unit as recommended may breach the terms of the warranty. See full warranty terms and conditions for further information.

How to Change the Filter

- Isolate the unit from the mains supply.
- Remove the filter caps, replace both filters then reinsert filter caps.
- Engage the mains supply then reset the filter indication by pressing the minus button for 10 seconds.

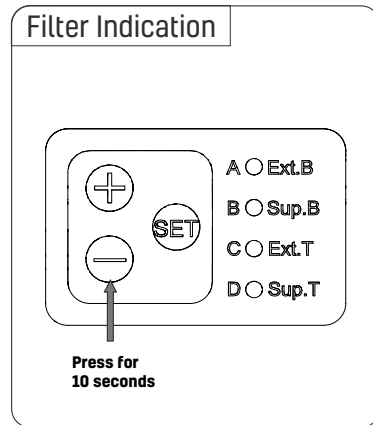
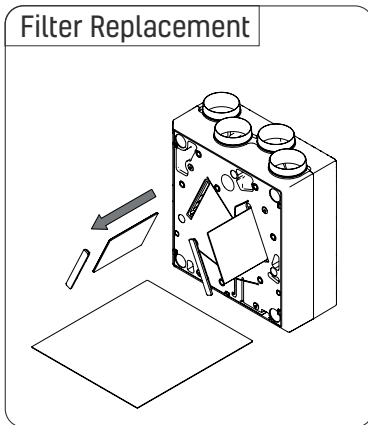

Spares/Accessories

Item Description	Order Code
Replacement Filter	FILTER-ESG3
125mm white supply valve	1DIFSUPPLY125WH
125mm white extract valve	1DIFEXTRACT125WH
150mm white supply valve	1DIFSUPPLY150WH
150mm white extract valve	1DIFEXTRACT150WH
Spare remote control	SWH-W-MVHR3
Condensate non-return valve (wall)	1ATUNVALVE

Warranty

We appreciate you choosing this quality EnviroVent product, which is designed and manufactured in Harrogate, North Yorkshire. We are confident that you will be delighted with the performance of the system and the resulting improvement in air quality in your home after it has been installed.

The energiSava® 260 units are covered by a parts only 2-year warranty. Please note that conditions and exclusions apply to the warranty which can be found at www.envirovent.com/warranty

Your unit serial number

What should I do if I have a problem?

If you encounter any problems with your unit, please fee free to call us on **01423 810 810**



AFTER INSTALLATION THE END USER SHOULD
KEEP THIS GUIDE FOR FUTURE REFERENCE

**DO NOT
THROW AWAY**



AFTER INSTALLATION THE END USER SHOULD
KEEP THIS GUIDE FOR FUTURE REFERENCE

**DO NOT
THROW AWAY**

AFTER COMPLETING INSTALLATION, PASS THIS GUIDE
ONTO THE END USER FOR FUTURE REFERENCE
DO NOT THROW AWAY

envirovent®

Leading Manufacturer & Supplier of
Innovative & Sustainable Ventilation Systems

EnviroVent Ltd
Harrogate West Business Park
Unit 1 Bardner Bank
Killinghall
Harrogate
HG3 2SP

T / 01423 810 810
E / info@envirovent.com
W / envirovent.com

Boxed unit weight: 16kg Unboxed unit weight: 14kg

E&OE | MKT ENV626 - V14 - 02.12.25

Due to our policy of continuous innovation and improvement EnviroVent reserves the right to alter products specification and appearance without notice.

We want to hear from you

Your feedback is important to us as we strive to improve our products, services, and overall customer experience. Please email us to help us serve you better: feedback@envirovent.com